

Position	Qty.	Description
	1	<p><b>TP 32-180/2 A-F-A-BQQE</b></p>  <p>Product No.: <a href="#">98592079</a></p> <p>Single-stage, close-coupled, volute pump with in-line suction and discharge ports of identical diameter. The pump is of the top-pull-out design, i.e. the power head (motor, pump head and impeller) can be removed for maintenance or service while the pump housing remains in the pipework.</p> <p>The pump is fitted with an unbalanced rubber bellows seal. The shaft seal is according to EN 12756. Pipework connection is via PN 6/10 DIN flanges (EN 1092-2 and ISO 7005-2).</p> <p>The pump is fitted with a fan-cooled asynchronous motor.</p> <p><b>Liquid:</b>  Pumped liquid: Water  Liquid temperature range: -25 .. 120 °C  Liquid temperature during operation: 20 °C  Density: 998.2 kg/m<sup>3</sup></p> <p><b>Technical:</b>  Speed for pump data: 2840 rpm  Rated flow: 6.2 m<sup>3</sup>/h  Rated head: 11.9 m  Actual impeller diameter: 118 mm  Primary shaft seal: BQQE  Curve tolerance: ISO9906:2012 3B</p> <p><b>Materials:</b>  Pump housing: Cast iron  EN-JL1040  ASTM A48-40 B  Impeller: Stainless steel  DIN W.-Nr. 1.4301  AISI 304</p> <p><b>Installation:</b>  Range of ambient temperature: -30 .. 40 °C  Maximum operating pressure: 10 bar  Flange standard: DIN  Pipe connection: DN 32  Pump inlet: DN 32  Pump outlet: DN 32  Pressure rating: PN 6/10  Port-to-port length: 280 mm  Flange size for motor: FT85</p> <p><b>Electrical data:</b>  Motor type: 71B  IE Efficiency class: IE3  Rated power - P2: 0.55 kW  Power (P2) required by pump: 0.55 kW  Mains frequency: 50 Hz</p>

Position	Qty.	Description
		Rated voltage: 3 x 220-240D/380-415Y V Rated current: 2,50/1,44 A Starting current: 580-620 % Cos phi - power factor: 0,80-0,70 Rated speed: 2830-2850 rpm Efficiency: IE3 77,8% Motor efficiency at full load: 77.8 % Motor efficiency at 3/4 load: 81.5 % Motor efficiency at 1/2 load: 79.5 % Number of poles: 2 Enclosure class (IEC 34-5): 55 Dust/Jetting Insulation class (IEC 85): F  <b>Others:</b> Minimum efficiency index, MEI : 0.64 ErP status: EuP Standalone/Prod. Net weight: 23.2 kg Gross weight: 26.7 kg Shipping volume: 0.06 m <sup>3</sup> Danish VVS No.: VVS NO 381811180 Norwegian NRF no.: NRF NO 9043527

## 98592079 TP 32-180/2 50 Hz

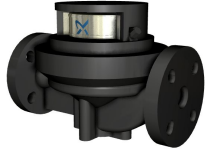
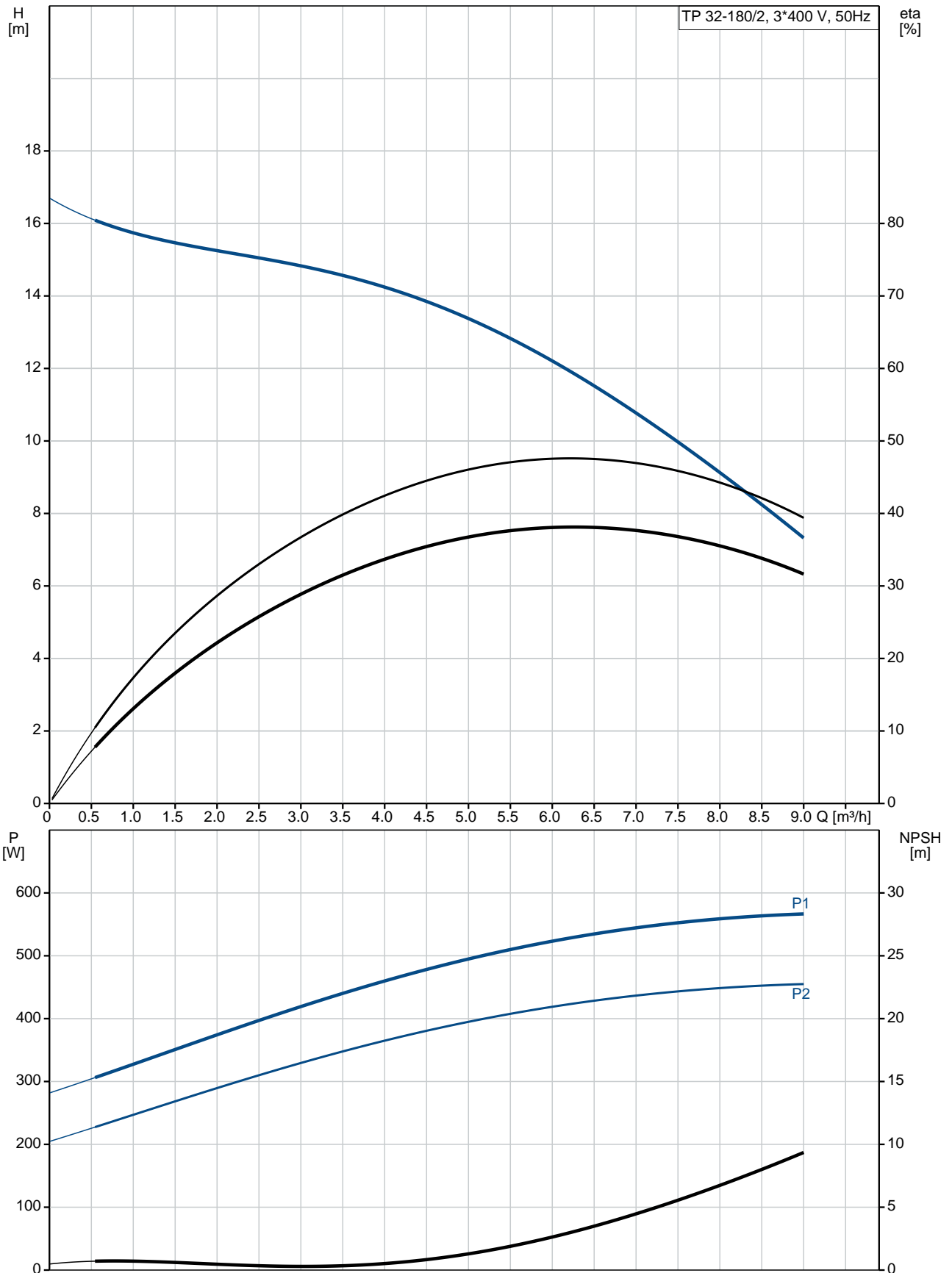

Description	Value
<b>General information:</b>	
Product name:	TP 32-180/2 A-F-A-BQQE
Product No:	98592079
EAN number:	5711497802781
<b>Technical:</b>	
Speed for pump data:	2840 rpm
Rated flow:	6.2 m <sup>3</sup> /h
Rated head:	11.9 m
Head max:	180 dm
Actual impeller diameter:	118 mm
Primary shaft seal:	BQQE
Curve tolerance:	ISO9906:2012 3B
Pump version:	A
Model:	A
<b>Materials:</b>	
Pump housing:	Cast iron EN-JL1040 ASTM A48-40 B
Impeller:	Stainless steel DIN W.-Nr. 1.4301 AISI 304
Material code:	A
<b>Installation:</b>	
Range of ambient temperature:	-30 .. 40 °C
Maximum operating pressure:	10 bar
Flange standard:	DIN
Connect code:	F
Pipe connection:	DN 32
Pump inlet:	DN 32
Pump outlet:	DN 32
Pressure rating:	PN 6/10
Port-to-port length:	280 mm
Flange size for motor:	FT85
<b>Liquid:</b>	
Pumped liquid:	Water
Liquid temperature range:	-25 .. 120 °C
Liquid temperature during operation:	20 °C
Density:	998.2 kg/m <sup>3</sup>
<b>Electrical data:</b>	
Motor type:	71B
IE Efficiency class:	IE3
Rated power - P2:	0.55 kW
Power (P2) required by pump:	0.55 kW
Mains frequency:	50 Hz
Rated voltage:	3 x 220-240D/380-415Y V
Rated current:	2,50/1,44 A
Starting current:	580-620 %
Cos phi - power factor:	0,80-0,70
Rated speed:	2830-2850 rpm
Efficiency:	IE3 77,8%
Motor efficiency at full load:	77.8 %
Motor efficiency at 3/4 load:	81.5 %
Motor efficiency at 1/2 load:	79.5 %
Number of poles:	2

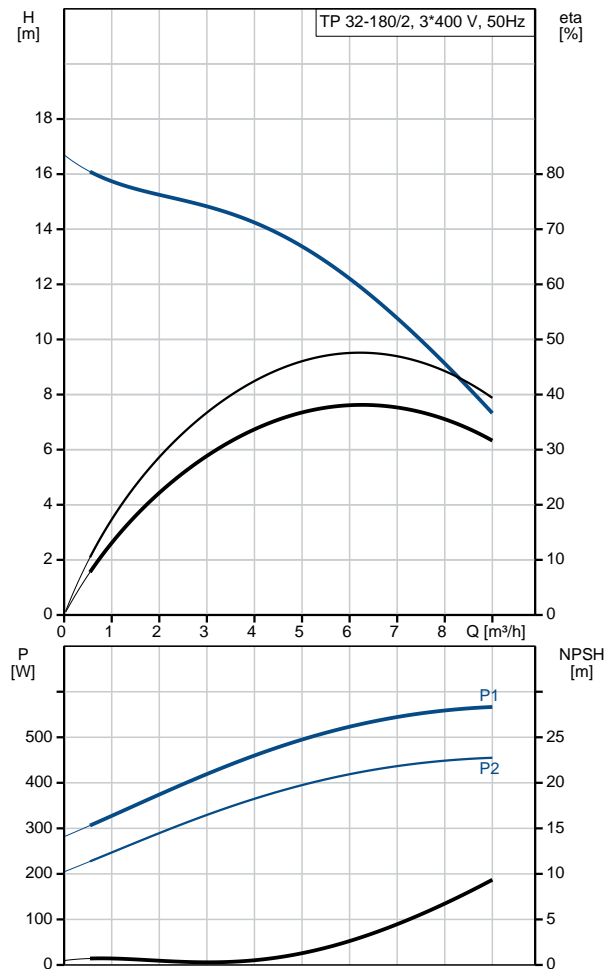



Company name:

Created by:

Phone:

Date:

19/01/2018

Description	Value
Enclosure class (IEC 34-5):	55 Dust/Jetting
Insulation class (IEC 85):	F
Motor protec:	NONE
Motor No:	85805103
<b>Others:</b>	
Minimum efficiency index, MEI :	0.64
ErP status:	EuP Standalone/Prod.
Net weight:	23.2 kg
Gross weight:	26.7 kg
Shipping volume:	0.06 m <sup>3</sup>
Danish VVS No.:	VVS NO 381811180
Norwegian NRF no.:	NRF NO 9043527

## 98592079 TP 32-180/2 50 Hz

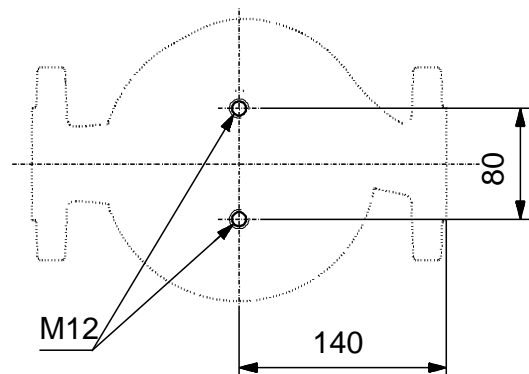
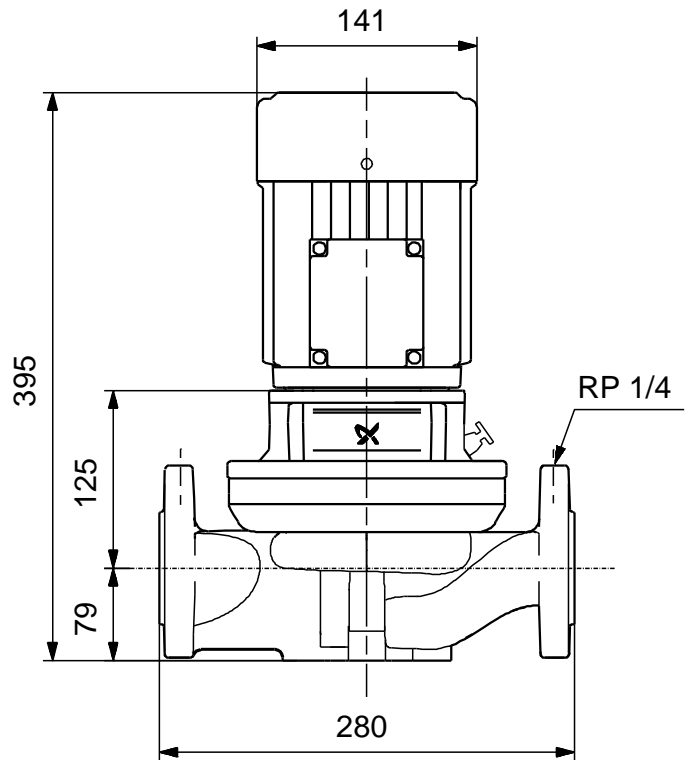
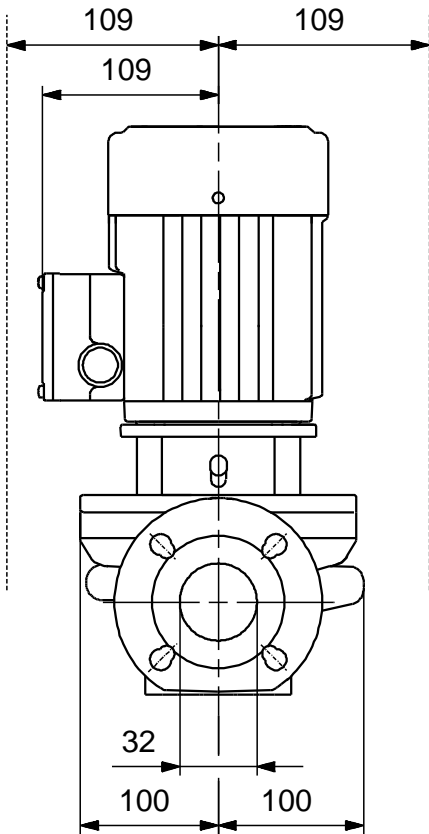

Note! All units are in [mm] unless others are stated.  
Disclaimer: This simplified dimensional drawing does not show all details.

**98592079 TP 32-180/2 50 Hz**

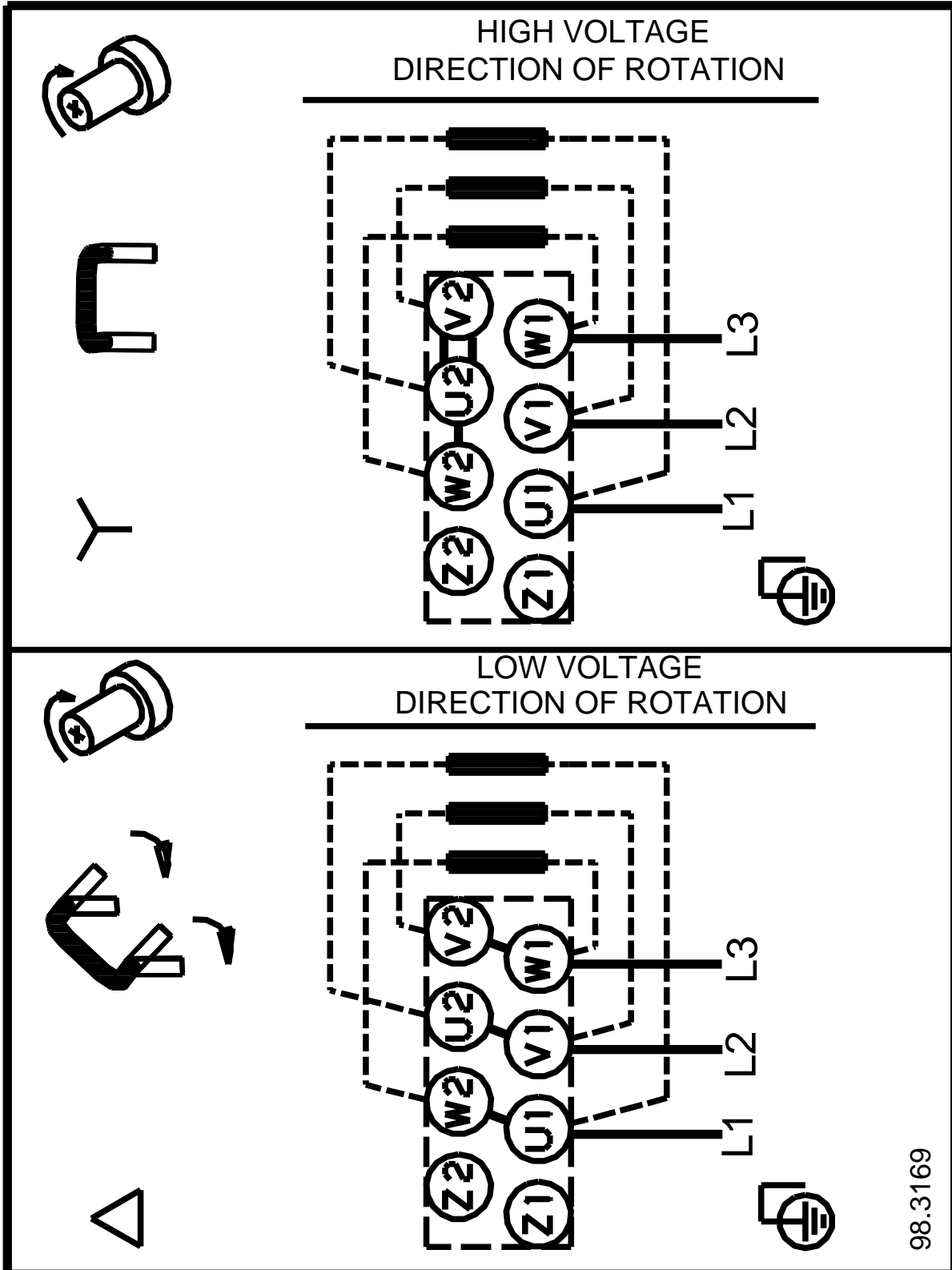

98.3169

Note! All units are in [mm] unless others are stated.