

Qty. Description

1 TPE 25-80/2 A-O-A-BQQE



Note! Product picture may differ from actual product

Product No.: [98525614](#)

Single-stage, close-coupled, volute pump with in-line suction and discharge ports of identical diameter. The pump is of the top-pull-out design, i.e. the power head (motor, pump head and impeller) can be removed for maintenance or service while the pump housing remains in the pipework.

TPE 25-80/2 A-O-A-BQQE The pump is fitted with an unbalanced rubber bellows seal. TPE 25-80/2 A-O-A-BQQE TPE 25-80/2 A-O-A-BQQE The shaft seal is according to EN 12756. Pipework connection is via PN 10 union connections (ISO 228-1).

Pipework connection is via PN 10 union connections (ISO 228-1).

The pump is fitted with a fan-cooled, permanent-magnet synchronous motor. The motor efficiency is classified as IE5 in accordance with IEC 60034-30-2.

The motor includes a frequency converter and PI controller in the motor terminal box. This enables continuously variable control of the motor speed, which again enables adaptation of the performance to a given requirement.

Further product details

A control panel enables setting of required setpoint as well as setting of pump to "Min." or "Max." operation or to "Stop". The control panel has indicator lights for "Operation" and "Fault".

Communication with the pump is possible by means of the Grundfos GO Remote (accessory). The remote control enables further settings as well as reading out of a number of parameters such as "Actual value", "Speed", "Power input" and total "Power consumption".

An operating panel on the motor terminal box enables setting of required setpoint as well as setting of pump to "Min." or "Max." operation or to "Stop". The Grundfos Eye indicator on the operating panel provides visual indication of pump status:

- "Power on": Motor is running (rotating green indicator lights) or not running (permanently green indicator lights)
- "Warning": Motor is still running (rotating yellow indicator lights) or has stopped (permanently yellow indicator lights)
- "Alarm": Motor has stopped (flashing red indicator lights).

Communication with the pump is possible by means of Grundfos GO Remote (accessory). The remote control enables further settings as well as reading out of a number of parameters such as "Actual value", "Speed", "Power input" and total "Power consumption".

Pump

Pump housing and pump head are electrocoated to improve the corrosion resistance.

Electrocoating includes:

- 1) Alkaline-based cleaning.
- 2) Pretreatment with zinc phosphate coating.
- 3) Cathodic electrocoating (epoxy).
- 4) Curing of paint film at 200-250 °C.

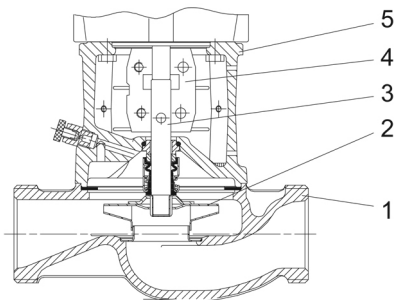

- 1: Pump housing
- 2: Impeller
- 3: Shaft
- 4: Coupling
- 5: Pump head

The pump housing is provided with a replaceable stainless steel/PTFE neck ring to reduce the amount of liquid running from the discharge side of the impeller to the suction side. The impeller is secured with a split cone pressed onto the shaft.

The pump is fitted with an unbalanced rubber bellows seal with torque transmission across the spring and around the bellows. Due to the bellows, the seal does not wear the shaft, and the axial movement is not prevented by deposits on the shaft.

Primary seal:

- Rotating seal ring material: silicon carbide (SiC)
- Stationary seat material: silicon carbide (SiC)

This material pairing is used where higher corrosion resistance is required. The high hardness of this material pairing offers good resistance against abrasive particles.

Secondary seal material: EPDM (ethylene-propylene rubber)

EPDM has excellent resistance to hot water. EPDM is not suitable for mineral oils.

A circulation of liquid through the duct of the air vent screw ensures lubrication and cooling of the shaft seal.

The motor stool forms connection between the pump housing and the motor, and is equipped with a manual air vent screw for venting of the pump housing and the shaft seal chamber. The sealing between motor stool and pump housing is an O-ring or a flat gasket.

The central part of the motor stool is provided with guards for protection against the shaft and coupling. Motor and pump shaft are connected via a shell coupling.

Motor

The motor is a totally enclosed, fan-cooled motor with principal dimensions to IEC and DIN standards. Electrical tolerances comply with IEC 60034.

The motor is flange-mounted with tapped-hole flange (FT).

Motor-mounting designation in accordance with IEC 60034-7: IM B 14, IM V 18 (Code I) / IM 3601, IM 3611 (Code II).

The motor efficiency is classified as IE5 in accordance with IEC 60034-30-2.

The motor requires no external motor protection. The motor control unit incorporates protection against slow- and quick-rising temperatures, e.g. constant overload and stalled conditions.

TPE 25-80/2 A-O-A-BQQE The terminal box holds terminals for these connections:

- one dedicated digital input
- two analog inputs, 0(4)-20 mA, 0-5 V, 0-10 V, 0.5 - 3.5 V
- 5 V voltage supply to potentiometer and sensor
- one configurable digital input or open-collector output
- Grundfos Digital Sensor input and output
- 24 V voltage supply for sensors
- two signal-relay outputs (potential-free contacts)
- GENIbus connection
- interface for Grundfos CIM fieldbus module.

Qty.	Description
	<p>TPE 25-80/2 A-O-A-BQQE The terminal box holds terminals for these connections:</p> <ul style="list-style-type: none"> - one dedicated digital input - two analog inputs, 0(4)-20 mA, 0-5 V, 0-10 V, 0.5 - 3.5 V - 5 V voltage supply to potentiometer and sensor - one configurable digital input or open-collector output - Grundfos Digital Sensor input and output - 24 V voltage supply for sensors - two signal relay outputs (potential-free contacts) - the two power heads communicate via wireless GENIair or wired GENI connection - interface for Grundfos CIM fieldbus module. <p>Technical data</p> <p>Controls: Frequency converter: Built-in</p> <p>Liquid: Pumped liquid: Water Liquid temperature range: -25 .. 120 °C Selected liquid temperature: 20 °C Density at selected liquid temperature: 998.2 kg/m³</p> <p>Technical: Pump speed on which pump data are based: 2820 rpm Rated flow: 6.32 m³/h Rated head: 4.04 m Actual impeller diameter: 80 mm Primary shaft seal: BQQE Curve tolerance: ISO9906:2012 3B</p> <p>Materials: Pump housing: Cast iron EN-JL1020 ASTM A48-25B Impeller: Composite PES/PP 30% GF</p> <p>Installation: Range of ambient temperature: -20 .. 50 °C Maximum operating pressure: 10 bar Flange standard: UNION Pipe connection: G 1 1/2 Pressure rating: PN 10 Port-to-port length: 180 mm Flange size for motor: FT85</p> <p>Electrical data: Motor type: 71A IE Efficiency class: IE5 Rated power - P2: 0.18 kW Mains frequency: 50 Hz Rated voltage: 1 x 200-240 V Rated current: 1.75-1.50 A Cos phi - power factor: 0.95 Rated speed: 360-4000 rpm Efficiency: 81.1% Motor efficiency at full load: 81.1 % Enclosure class (IEC 34-5): IP55 Insulation class (IEC 85): F Motor No: 99350862</p>



Company name:

Created by:

Phone:

Date:

20/08/2019

Qty.	Description
------	-------------

Others:

Minimum efficiency index, MEI $\eta_{\%}$: 0.55

ErP status: EuP Standalone/Prod.

Net weight: 12.3 kg

Gross weight: 14.3 kg

Shipping volume: 0.045 m³

Danish VVS No.: 382000080

98525614 TPE 25-80/2 A-O-A-BQQE 50 Hz

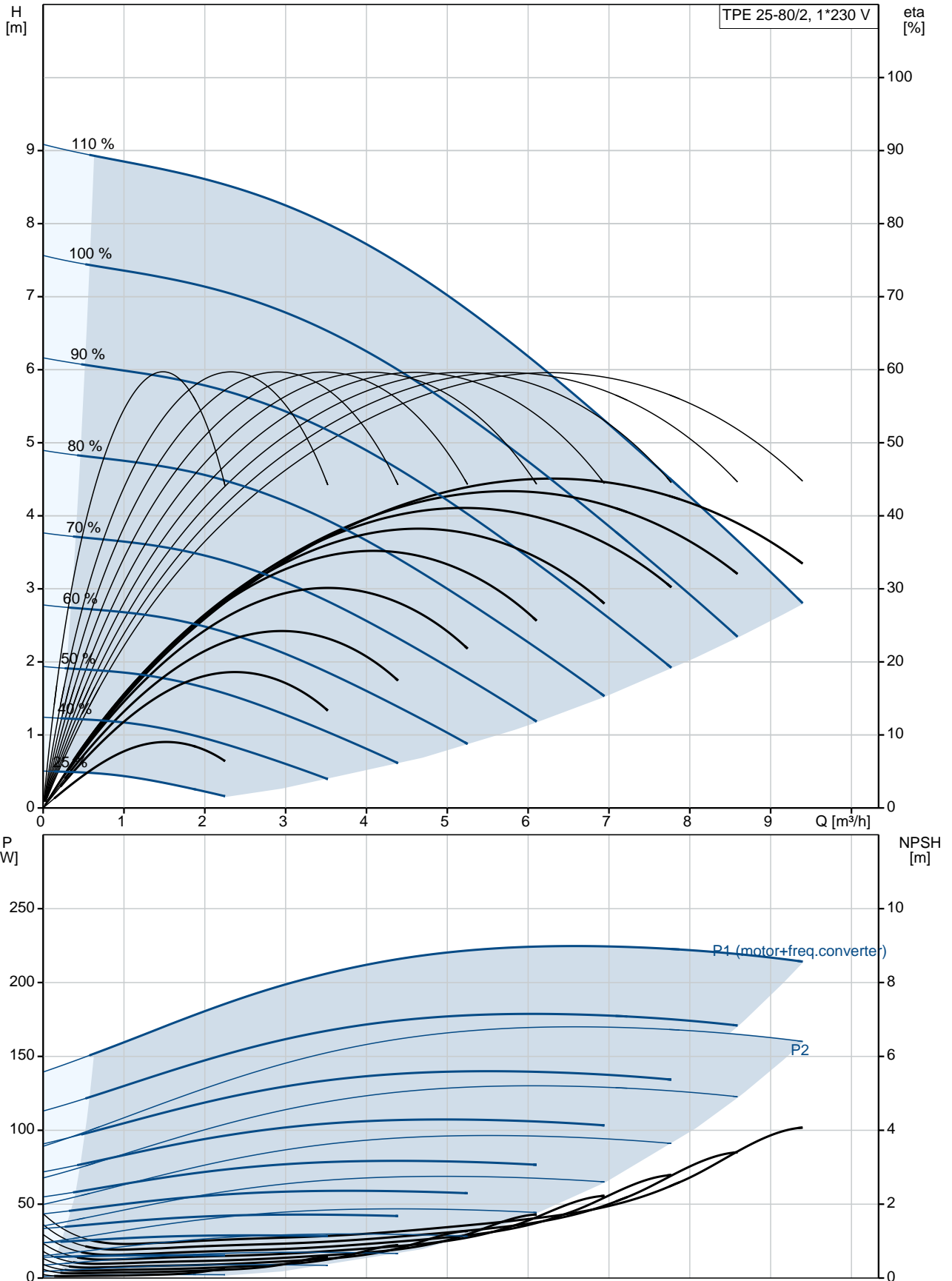

Description	Value
General information:	
Product name:	TPE 25-80/2 A-O-A-BQQE
Product No:	98525614
EAN number:	5711496569197 5711496569197
Technical:	
Pump speed on which pump data are based:	2820 rpm
Rated flow:	6.32 m ³ /h
Rated head:	4.04 m
Head max:	80 dm
Actual impeller diameter:	80 mm
Primary shaft seal:	BQQE
Curve tolerance:	ISO9906:2012 3B
Pump version:	A
Model:	B
Materials:	
Pump housing:	Cast iron EN-JL1020 ASTM A48-25B
Impeller:	Composite PES/PP 30% GF
Material code:	A
Installation:	
Range of ambient temperature:	-20 .. 50 °C
Maximum operating pressure:	10 bar
Flange standard:	UNION
Pipe connection:	G 1 1/2
Pressure rating:	PN 10
Port-to-port length:	180 mm
Flange size for motor:	FT85
Connect code:	O
Liquid:	
Pumped liquid:	Water
Liquid temperature range:	-25 .. 120 °C
Selected liquid temperature:	20 °C
Density at selected liquid temperature:	998.2 kg/m ³
Electrical data:	
Motor type:	71A
IE Efficiency class:	IE5
Rated power - P2:	0.18 kW
Mains frequency:	50 Hz
Rated voltage:	1 x 200-240 V
Rated current:	1.75-1.50 A
Cos phi - power factor:	0.95
Rated speed:	360-4000 rpm
Efficiency:	81.1%
Motor efficiency at full load:	81.1%
Enclosure class (IEC 34-5):	IP55
Insulation class (IEC 85):	F
Motor protec:	YES
Motor No:	99350862
Controls:	
Control panel:	HMI200 - Standard
Function Module:	FM300 - Advanced
Frequency converter:	Built-in
Others:	
Minimum efficiency index, MEI $\hat{a}\%_{\text{0}\text{¥}}$:	0.55

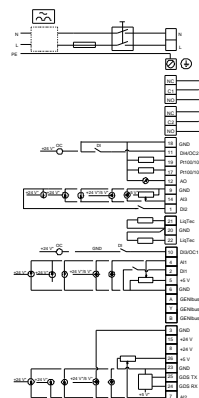
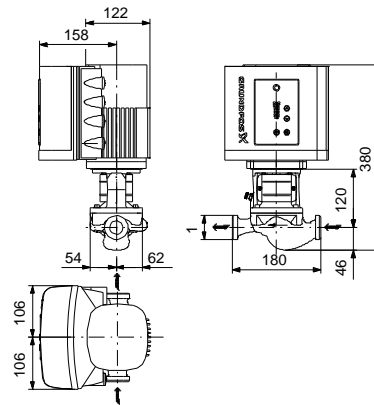
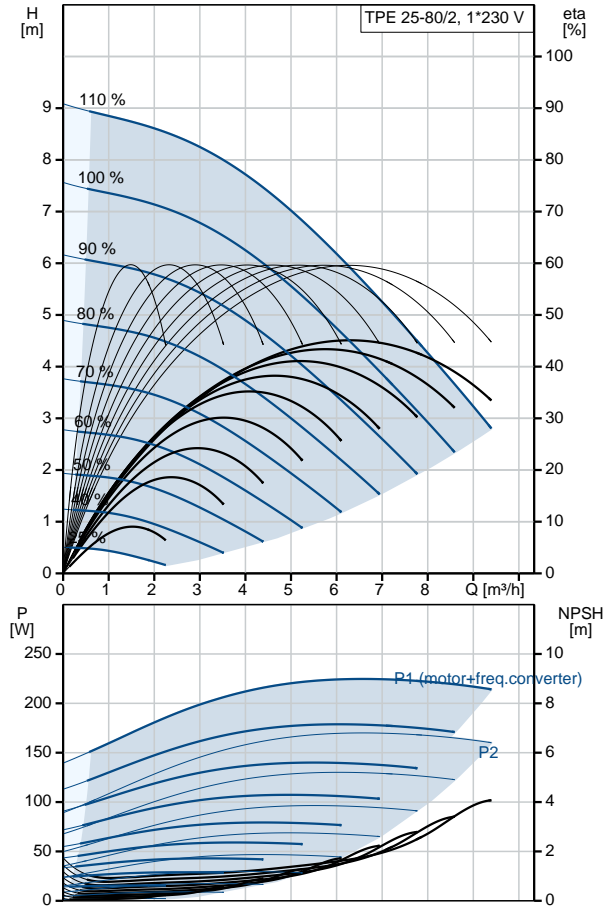



Company name:

Created by:

Phone:

Date:

20/08/2019

Description	Value
ErP status:	EuP Standalone/Prod.
Net weight:	12.3 kg
Gross weight:	14.3 kg
Shipping volume:	0.045 m ³
Config. file no:	98545913
Danish VVS No.:	382000080

98525614 TPE 25-80/2 A-O-A-BQQE 50 Hz

