

Position	Qty.	Description
	1	<p data-bbox="320 338 651 365"><b>HYDRO MULTI-E 2 CME5-06</b></p> <div data-bbox="432 389 580 618" style="text-align: center;">  </div> <p data-bbox="711 611 1193 633" style="text-align: center;"><b>Note! Product picture may differ from actual product</b></p> <p data-bbox="320 642 584 665">Product No.: <a href="#">98486750</a></p> <p data-bbox="320 701 1445 754">GRUNDFOS Hydro Multi-E booster sets are designed for the transfer and pressure boosting of clean water in waterworks, blocks of flats, hotels, industry, hospitals, schools, etc.</p> <p data-bbox="320 759 1445 813">GRUNDFOS Hydro Multi-E booster set consists of 2 to 3 CME pumps coupled in parallel and mounted on a common base frame provided with all the necessary fittings.</p> <p data-bbox="320 848 1378 875">Hydro Multi-E is mounted on a common base frame made of stainless steel (DIN W.-Nr. 1.4301).</p> <p data-bbox="320 880 1445 1001">On the suction side are fitted a suction manifold (DIN W.-Nr. 1.4401 or DIN W.-Nr. 1.4571) , a pressure switch mounted on a drainable valve and an isolating valve. On the discharge side of the pumps are fitted a non-return valve, an isolating valve, a pressure gauge, two pressure transmitters mounted on a drainable valve, a diaphragm tank and a stainless steel discharge manifold (DIN W.-Nr. 1.4401 or DIN W.-Nr. 1.4571).</p> <p data-bbox="320 1016 1086 1043">The Hydro Multi-E is fitted with an on/off-switch for the supply voltage.</p> <p data-bbox="320 1079 1398 1133">The Hydro Multi-E is designed for maintaining a constant pressure regardless of flow changes and fluctuation.</p> <p data-bbox="320 1169 1347 1223">The internal PI-controller regulates the number of running pumps and the speed of the pumps according to the required flow.</p> <p data-bbox="320 1258 1458 1312">The system can be operated directly on the panel of any of the pumps or via Grundfos GO (available as accessory)</p> <p data-bbox="320 1348 979 1608">Besides the system features:                  2 Digital outputs                  2 Digital inputs (one used for dry run protection)                  2 Analogue inputs (one used for discharge pressure sensor)                  Multi-Master functionality                  2 Limit functions                  Set-point influence function                  Pipe filling function                  High Efficient PM motors</p> <p data-bbox="320 1644 708 1671">Available communication protocols:</p> <ul data-bbox="320 1675 526 1939" style="list-style-type: none"> <li>•LON</li> <li>•Profibus</li> <li>•Modbus</li> <li>•SMS/GSM/GPRS</li> <li>•GRM</li> <li>•BACnet</li> <li>•BACnet IP</li> <li>•Modbus TCP</li> <li>•PROFINET</li> </ul> <p data-bbox="320 1975 1426 2002">When delivered, the GRUNDFOS Hydro Multi-E booster set is factory tested and ready for operation.</p> <p data-bbox="320 2060 405 2087"><b>Liquid:</b></p>

Position	Qty.	Description
		<p>Pumped liquid: Water            Liquid temperature range: 5 .. 60 °C            Liquid temperature during operation: 20 °C            Density: 998.2 kg/m<sup>3</sup></p> <p><b>Materials:</b>            Pump housing: Stainless steel</p> <p><b>Installation:</b>            Maximum operating pressure: 10 bar            Maximum inlet pressure: PN 10 bar            Flange standard: DIN ISO 7/1            Manifold inlet: R 2            Manifold outlet: R 2</p> <p><b>Electrical data:</b>            IE Efficiency class: IE5            Power (P2) main pump: 2.2 kW            Mains frequency: 50 Hz            Rated voltage: 3 x 380-415 V            Rated current: 8.3 A            Start. method: electronically            Enclosure class (IEC 34-5): IP54</p> <p><b>Tank:</b>            Volume of pressure tank: 18 l            Diaphragm tank: Yes</p> <p><b>Others:</b>            Net weight: 90 kg            Gross weight: 112 kg            Shipping volume: 0.418 m<sup>3</sup>            Language: MULTI            Country of origin: GB            Custom tariff no.: 84137075</p>

Description	Value
<b>General information:</b>	
Product name:	HYDRO MULTI-E 2 CME5-06
Product No:	98486750
EAN number:	5711495954178
Price:	7.444,00 GBP
<b>Technical:</b>	
Min flow system:	0.47 m <sup>3</sup> /h
Max flow:	15.2 m <sup>3</sup> /h
Head max:	80.6 m
Pump name:	CME5-06
Number of pumps:	2
<b>Materials:</b>	
Pump housing:	Stainless steel
Manifolds:	Stainless steel
<b>Installation:</b>	
Maximum operating pressure:	10 bar
Maximum inlet pressure:	PN 10 bar
Flange standard:	DIN ISO 7/1
Manifold inlet:	R 2
Manifold outlet:	R 2
<b>Liquid:</b>	
Pumped liquid:	Water
Liquid temperature range:	5 .. 60 °C
Liquid temperature during operation:	20 °C
Density:	998.2 kg/m <sup>3</sup>
<b>Electrical data:</b>	
IE Efficiency class:	IE5
Power (P2) main pump:	2.2 kW
Mains frequency:	50 Hz
Rated voltage:	3 x 380-415 V
Rated current:	8.3 A
Start. method:	electronically
Enclosure class (IEC 34-5):	IP54
<b>Tank:</b>	
Volume of pressure tank:	18 l
Diaphragm tank:	Yes
<b>Others:</b>	
Net weight:	90 kg
Gross weight:	112 kg
Shipping volume:	0.418 m <sup>3</sup>
Language:	MULTI
Product range:	International
Country of origin:	GB
Custom tariff no.:	84137075

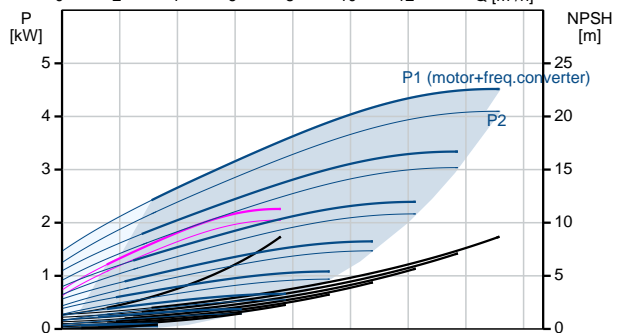
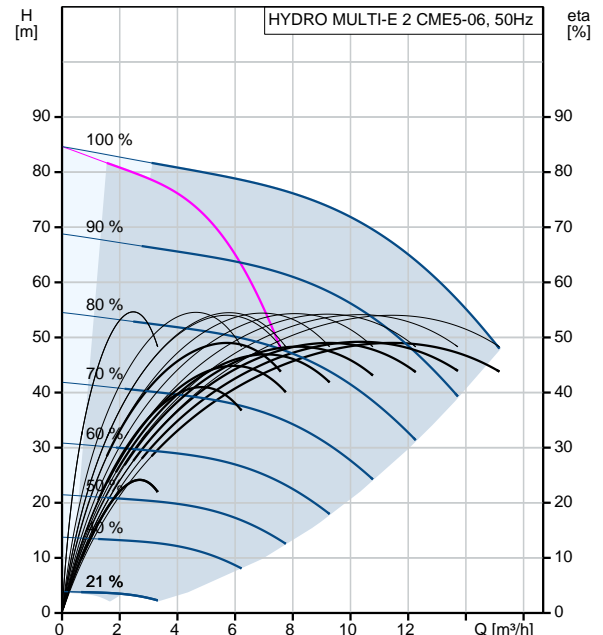

## 98486750 HYDRO MULTI-E 2 CME5-06 50 Hz

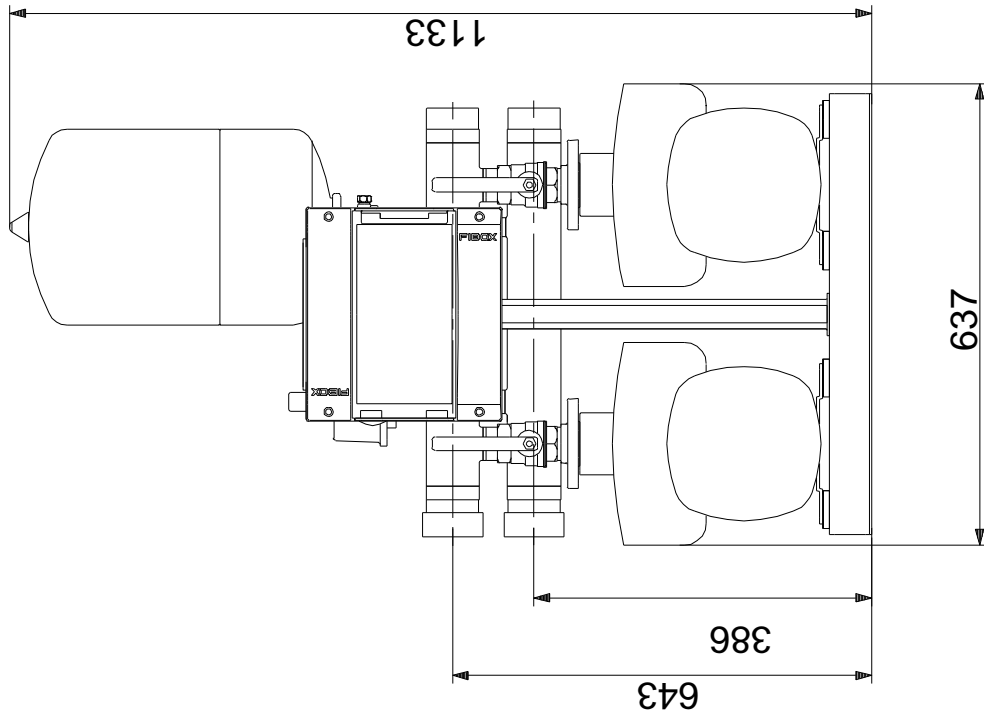
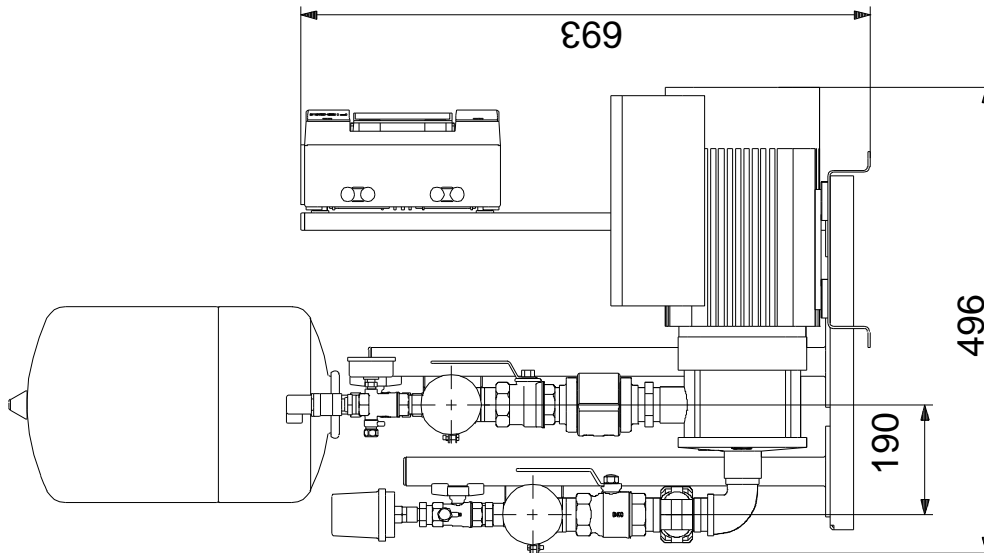

Note! All units are in [mm] unless others are stated.  
Disclaimer: This simplified dimensional drawing does not show all details.

## 98486750 HYDRO MULTI-E 2 CME5-06 50 Hz

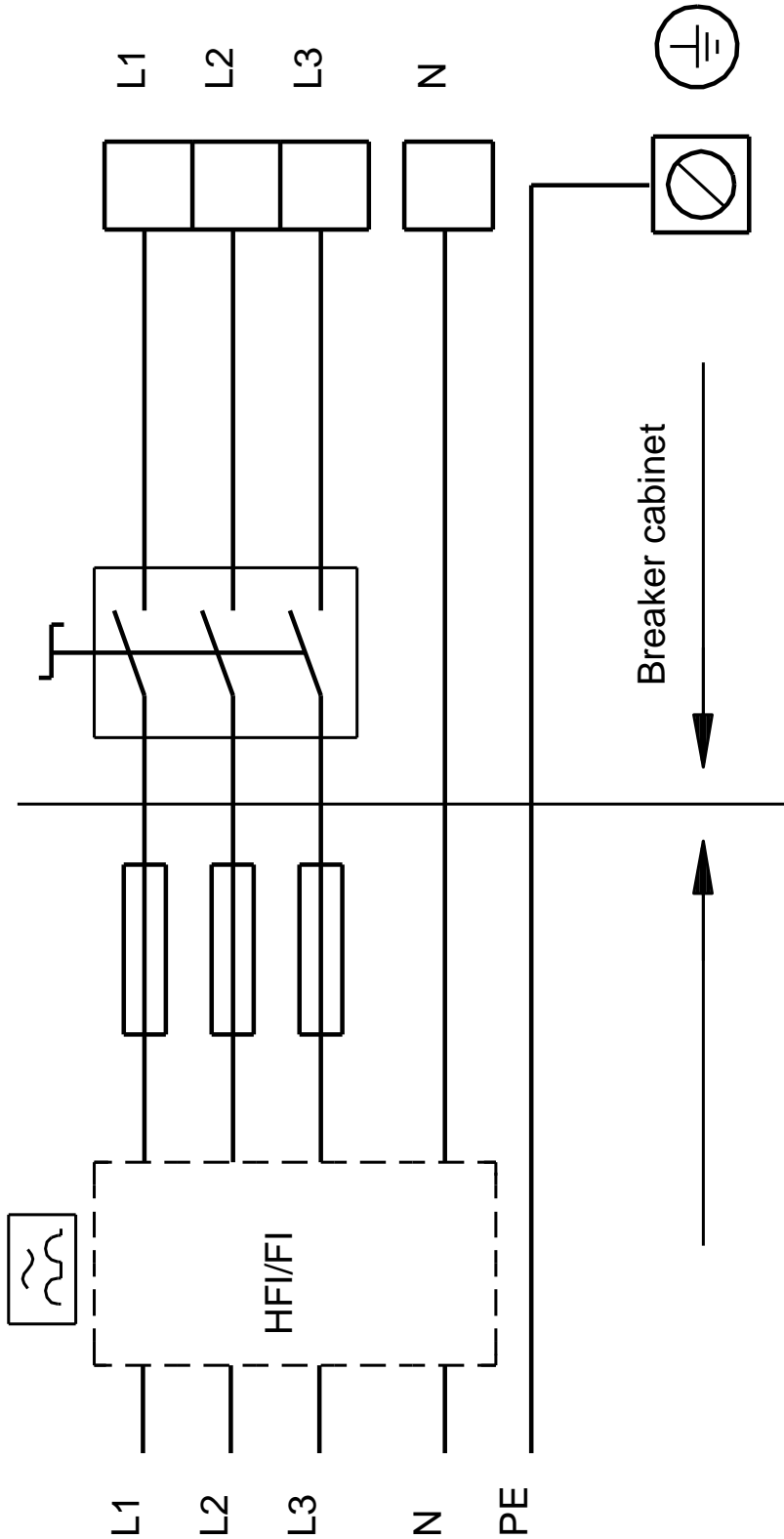

Note! All units are in [mm] unless others are stated.