

Qty.	Description
1	<p data-bbox="199 336 534 369"><b>TPE2 32-200-N A-F-A-BQQE</b></p>  <p data-bbox="199 660 470 694">Product No.: <a href="#">98438342</a></p> <p data-bbox="199 716 1444 795">Single-stage, close-coupled, volute pump with in-line suction and discharge ports of identical diameter. The pump is of the top-pull-out design, i.e. the power head (motor, pump head and impeller) can be removed for maintenance or service while the pump housing remains in the pipework.</p> <p data-bbox="199 806 1412 862">The shaft seal is according to EN 12756. Pipework connection is via PN 6/10 DIN flanges (EN 1092-2 and ISO 7005-2).</p> <p data-bbox="199 862 1444 918">The pump is fitted with a fan-cooled, permanent-magnet synchronous motor. The motor efficiency is classified as IE5 in accordance with IEC 60034-30-2.</p> <p data-bbox="199 918 1428 974">The motor includes a frequency converter and PI controller in the motor terminal box. This enables continuously variable control of the motor speed, which again enables adaptation of the performance to a given requirement.</p> <p data-bbox="199 1041 319 1070"><b>Controls:</b></p> <p data-bbox="199 1070 646 1102">Frequency converter: Built-in</p> <p data-bbox="199 1131 295 1160"><b>Liquid:</b></p> <p data-bbox="199 1160 638 1191">Pumped liquid: Water</p> <p data-bbox="199 1191 710 1223">Liquid temperature range: -25 .. 120 °C</p> <p data-bbox="199 1223 694 1254">Liquid temperature during operation: 20 °C</p> <p data-bbox="199 1254 702 1285">Density: 998.2 kg/m<sup>3</sup></p> <p data-bbox="199 1310 327 1339"><b>Technical:</b></p> <p data-bbox="199 1339 821 1370">Pump speed on which pump data are based: 5200 rpm</p> <p data-bbox="199 1370 678 1402">Rated flow: 14.9 m<sup>3</sup>/h</p> <p data-bbox="199 1402 646 1433">Rated head: 13.8 m</p> <p data-bbox="199 1433 646 1464">Actual impeller diameter: 62 mm</p> <p data-bbox="199 1464 646 1496">Primary shaft seal: BQQE</p> <p data-bbox="199 1496 766 1527">Curve tolerance: ISO9906:2012 3B</p> <p data-bbox="199 1552 327 1581"><b>Materials:</b></p> <p data-bbox="199 1581 750 1668">Pump housing: Cast iron EN-JL1040 ASTM A48-40 B</p> <p data-bbox="199 1668 885 1700">Impeller: Composite PES/PP 30% GF</p> <p data-bbox="199 1724 343 1753"><b>Installation:</b></p> <p data-bbox="199 1753 694 1785">Range of ambient temperature: -20 .. 50 °C</p> <p data-bbox="199 1785 646 1816">Maximum operating pressure: 10 bar</p> <p data-bbox="199 1816 614 1848">Flange standard: DIN</p> <p data-bbox="199 1848 646 1879">Pipe connection: DN 32</p> <p data-bbox="199 1879 662 1910">Pressure rating: PN 6/10</p> <p data-bbox="199 1910 662 1942">Port-to-port length: 220 mm</p> <p data-bbox="199 1942 614 1973">Flange size for motor: 56C</p> <p data-bbox="199 1998 383 2027"><b>Electrical data:</b></p> <p data-bbox="199 2027 614 2058">Motor type: 80A</p> <p data-bbox="199 2058 614 2089">IE Efficiency class: IE5</p> <p data-bbox="199 2089 662 2121">Rated power - P2: 0.75 kW</p>



Company name:

Created by:

Phone:

Date:

21/12/2018

**Qty. Description**

Mains frequency: 50 Hz  
Rated voltage: 1 x 200-240 V  
Rated current: 4.70-4.00 A  
Cos phi - power factor: 0.98  
Rated speed: 480-5900 rpm  
Efficiency: 85.7%  
Motor efficiency at full load: 85.7 %  
Enclosure class (IEC 34-5): IP55  
Insulation class (IEC 85): F

**Others:**

Minimum efficiency index, MEI =: 0.7  
ErP status: EuP Standalone/Prod.  
Net weight: 21.9 kg  
Gross weight: 29 kg  
Shipping volume: 0.1 m<sup>3</sup>  
Danish VVS No.: 382200200  
Norwegian NRF no.: 9043477  
Country of origin: HU  
Custom tariff no.: 84137051

## 98438342 TPE2 32-200-N A-F-A-BQQE 50 Hz

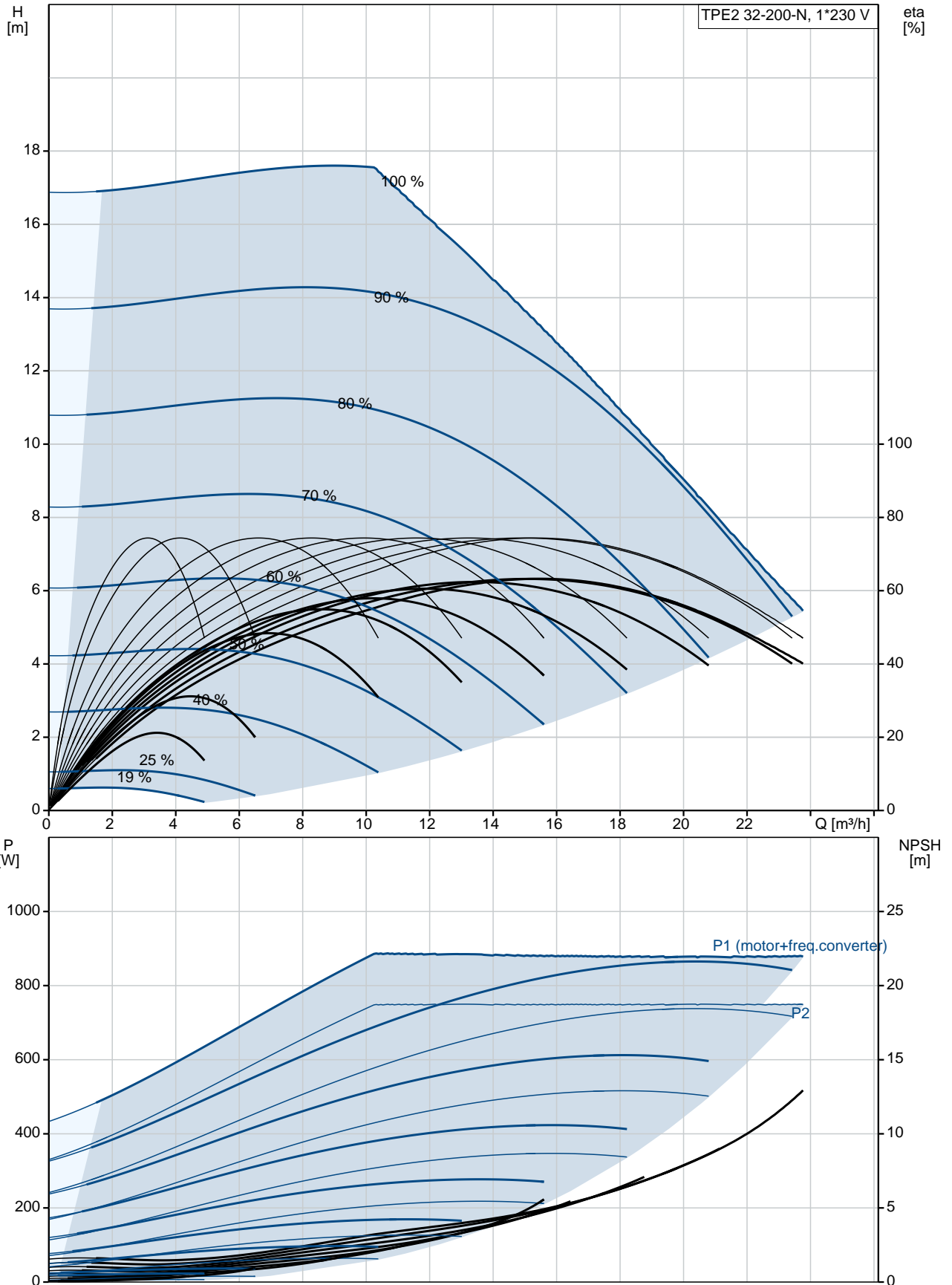

Description	Value
<b>General information:</b>	
Product name:	TPE2 32-200-N A-F-A-BQQE
Product No:	98438342
EAN number:	5711495017101
Price:	2.206,00 GBP
<b>Technical:</b>	
Pump speed on which pump data are based:	5200 rpm
Rated flow:	14.9 m <sup>3</sup> /h
Rated head:	13.8 m
Head max:	200 dm
Actual impeller diameter:	62 mm
Primary shaft seal:	BQQE
Curve tolerance:	ISO9906:2012 3B
Pump version:	A
Model:	A
<b>Materials:</b>	
Pump housing:	Cast iron
	EN-JL1040
	ASTM A48-40 B
Impeller:	Composite PES/PP 30% GF
Material code:	A
<b>Installation:</b>	
Range of ambient temperature:	-20 .. 50 °C
Maximum operating pressure:	10 bar
Flange standard:	DIN
Pipe connection:	DN 32
Pressure rating:	PN 6/10
Port-to-port length:	220 mm
Flange size for motor:	56C
Connect code:	F
<b>Liquid:</b>	
Pumped liquid:	Water
Liquid temperature range:	-25 .. 120 °C
Liquid temperature during operation:	20 °C
Density:	998.2 kg/m <sup>3</sup>
<b>Electrical data:</b>	
Motor type:	80A
IE Efficiency class:	IE5
Rated power - P2:	0.75 kW
Mains frequency:	50 Hz
Rated voltage:	1 x 200-240 V
Rated current:	4.70-4.00 A
Cos phi - power factor:	0.98
Rated speed:	480-5900 rpm
Efficiency:	85.7%
Motor efficiency at full load:	85.7%
Enclosure class (IEC 34-5):	IP55
Insulation class (IEC 85):	F
Motor protec:	YES
Motor No:	99138029
<b>Controls:</b>	
Control panel:	HMI200 - Standard
Function Module:	FM300 - Advanced
Frequency converter:	Built-in
<b>Others:</b>	
Minimum efficiency index, MEI =:	0.7
ErP status:	EuP Standalone/Prod.

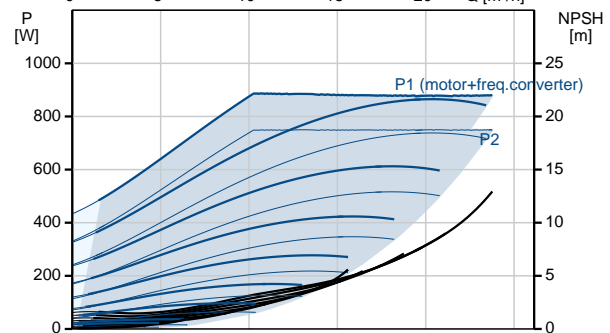
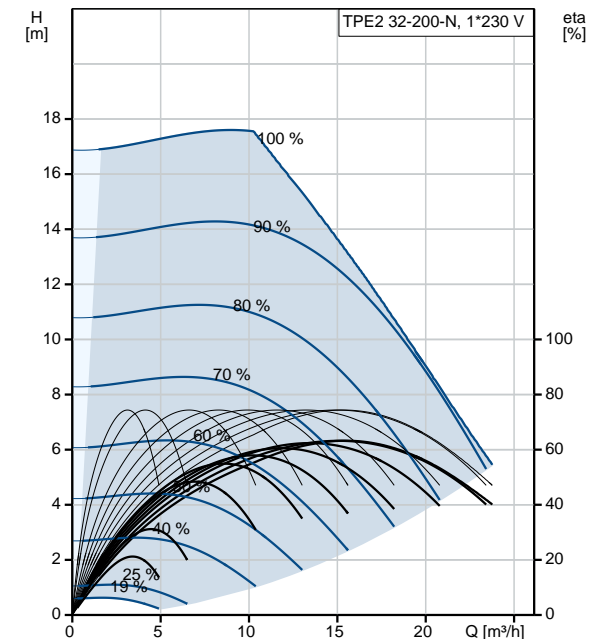



Company name:

Created by:

Phone:

Date:

21/12/2018

Description	Value
Net weight:	21.9 kg
Gross weight:	29 kg
Shipping volume:	0.1 m <sup>3</sup>
Config. file no:	98819167
Danish VVS No.:	382200200
Norwegian NRF no.:	9043477
Country of origin:	HU
Custom tariff no.:	84137051

## 98438342 TPE2 32-200-N A-F-A-BQQE 50 Hz

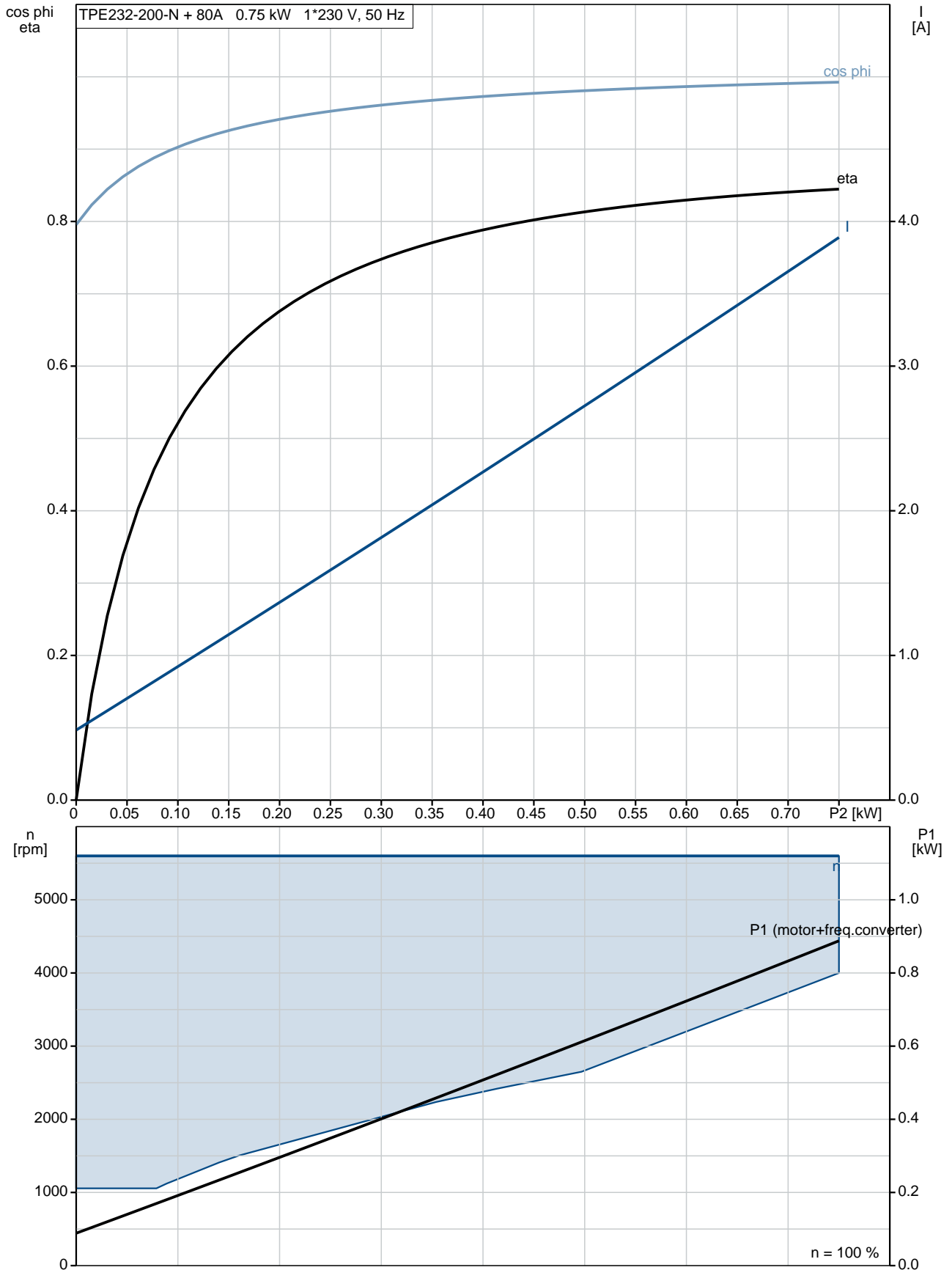

**98438342 TPE2 32-200-N A-F-A-BQQE 50 Hz**

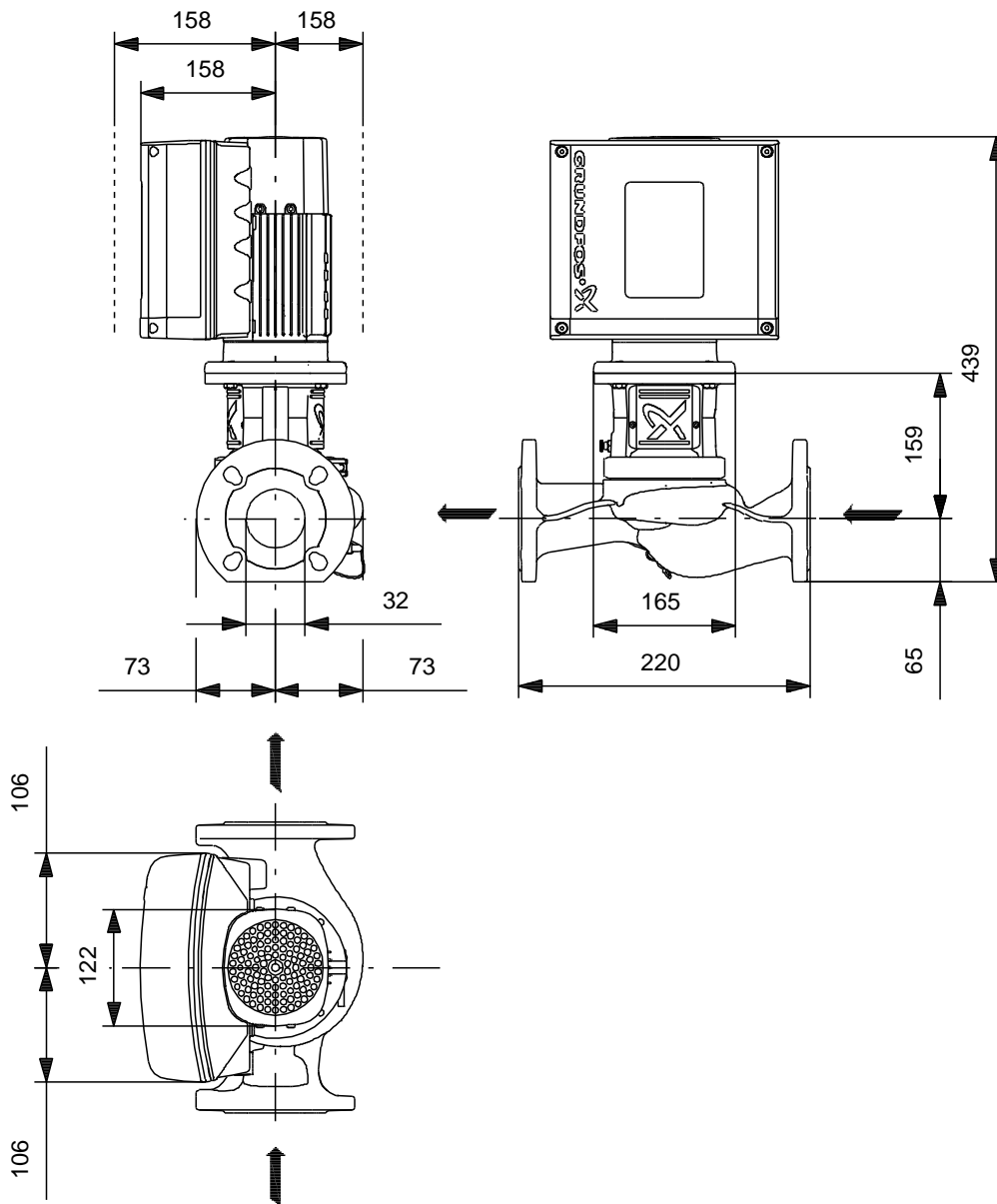

Note! All units are in [mm] unless others are stated.  
Disclaimer: This simplified dimensional drawing does not show all details.

## 98438342 TPE2 32-200-N A-F-A-BQQE 50 Hz

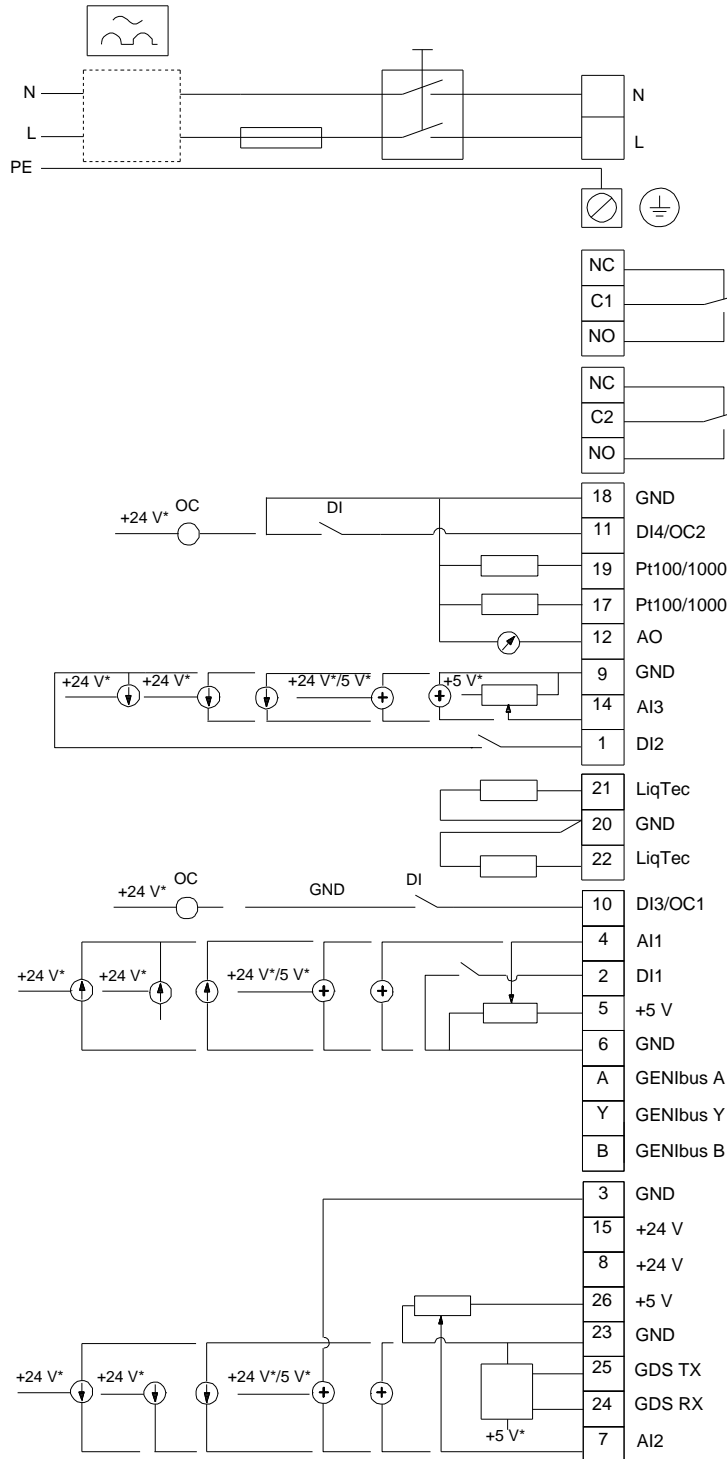

Note! All units are in [mm] unless others are stated.