

Qty.	Description
1	<p data-bbox="199 336 534 369">TPE2 40-200-N A-F-A-BQQE</p>  <p data-bbox="199 660 470 683">Product No.: 98437889</p> <p data-bbox="199 716 1444 795">Single-stage, close-coupled, volute pump with in-line suction and discharge ports of identical diameter. The pump is of the top-pull-out design, i.e. the power head (motor, pump head and impeller) can be removed for maintenance or service while the pump housing remains in the pipework.</p> <p data-bbox="199 806 1412 862">The shaft seal is according to EN 12756. Pipework connection is via PN 6/10 DIN flanges (EN 1092-2 and ISO 7005-2).</p> <p data-bbox="199 862 1444 918">The pump is fitted with a fan-cooled, permanent-magnet synchronous motor. The motor efficiency is classified as IE5 in accordance with IEC 60034-30-2.</p> <p data-bbox="199 918 1428 974">The motor includes a frequency converter and PI controller in the motor terminal box. This enables continuously variable control of the motor speed, which again enables adaptation of the performance to a given requirement.</p> <p data-bbox="199 1041 319 1064">Controls:</p> <p data-bbox="199 1064 646 1097">Frequency converter: Built-in</p> <p data-bbox="199 1131 295 1153">Liquid:</p> <p data-bbox="199 1153 638 1187">Pumped liquid: Water</p> <p data-bbox="199 1187 710 1220">Liquid temperature range: -25 .. 120 °C</p> <p data-bbox="199 1220 694 1254">Liquid temperature during operation: 20 °C</p> <p data-bbox="199 1254 702 1288">Density: 998.2 kg/m³</p> <p data-bbox="199 1310 327 1332">Technical:</p> <p data-bbox="199 1332 821 1366">Pump speed on which pump data are based: 5000 rpm</p> <p data-bbox="199 1366 678 1400">Rated flow: 20.5 m³/h</p> <p data-bbox="199 1400 646 1433">Rated head: 14.9 m</p> <p data-bbox="199 1433 646 1467">Actual impeller diameter: 74 mm</p> <p data-bbox="199 1467 646 1500">Primary shaft seal: BQQE</p> <p data-bbox="199 1500 766 1534">Curve tolerance: ISO9906:2012 3B</p> <p data-bbox="199 1545 327 1568">Materials:</p> <p data-bbox="199 1568 750 1668">Pump housing: Cast iron EN-JL1040 ASTM A48-40 B</p> <p data-bbox="199 1668 885 1702">Impeller: Composite PES/PP 30% GF</p> <p data-bbox="199 1724 343 1747">Installation:</p> <p data-bbox="199 1747 694 1780">Range of ambient temperature: -20 .. 50 °C</p> <p data-bbox="199 1780 646 1814">Maximum operating pressure: 10 bar</p> <p data-bbox="199 1814 614 1848">Flange standard: DIN</p> <p data-bbox="199 1848 646 1881">Pipe connection: DN 40</p> <p data-bbox="199 1881 662 1915">Pressure rating: PN 6/10</p> <p data-bbox="199 1915 662 1948">Port-to-port length: 250 mm</p> <p data-bbox="199 1948 614 1982">Flange size for motor: 56C</p> <p data-bbox="199 1993 383 2016">Electrical data:</p> <p data-bbox="199 2016 614 2049">Motor type: 80A</p> <p data-bbox="199 2049 614 2083">IE Efficiency class: IE5</p> <p data-bbox="199 2083 646 2116">Rated power - P2: 1.1 kW</p>

Qty.	Description
------	-------------

Mains frequency:	50 Hz
Rated voltage:	3 x 380-500 V
Rated current:	2.30-2.05 A
Cos phi - power factor:	0.88-0.74
Rated speed:	480-5900 rpm
Efficiency:	88.5%
Motor efficiency at full load:	88.5 %
Enclosure class (IEC 34-5):	IP55
Insulation class (IEC 85):	F

Others:

Minimum efficiency index, MEI =:	0.7
ErP status:	EuP Standalone/Prod.
Net weight:	24.5 kg
Gross weight:	32 kg
Shipping volume:	0.1 m ³
Norwegian NRF no.:	9043496
Country of origin:	HU
Custom tariff no.:	84137051

98437889 TPE2 40-200-N A-F-A-BQQE 50 Hz

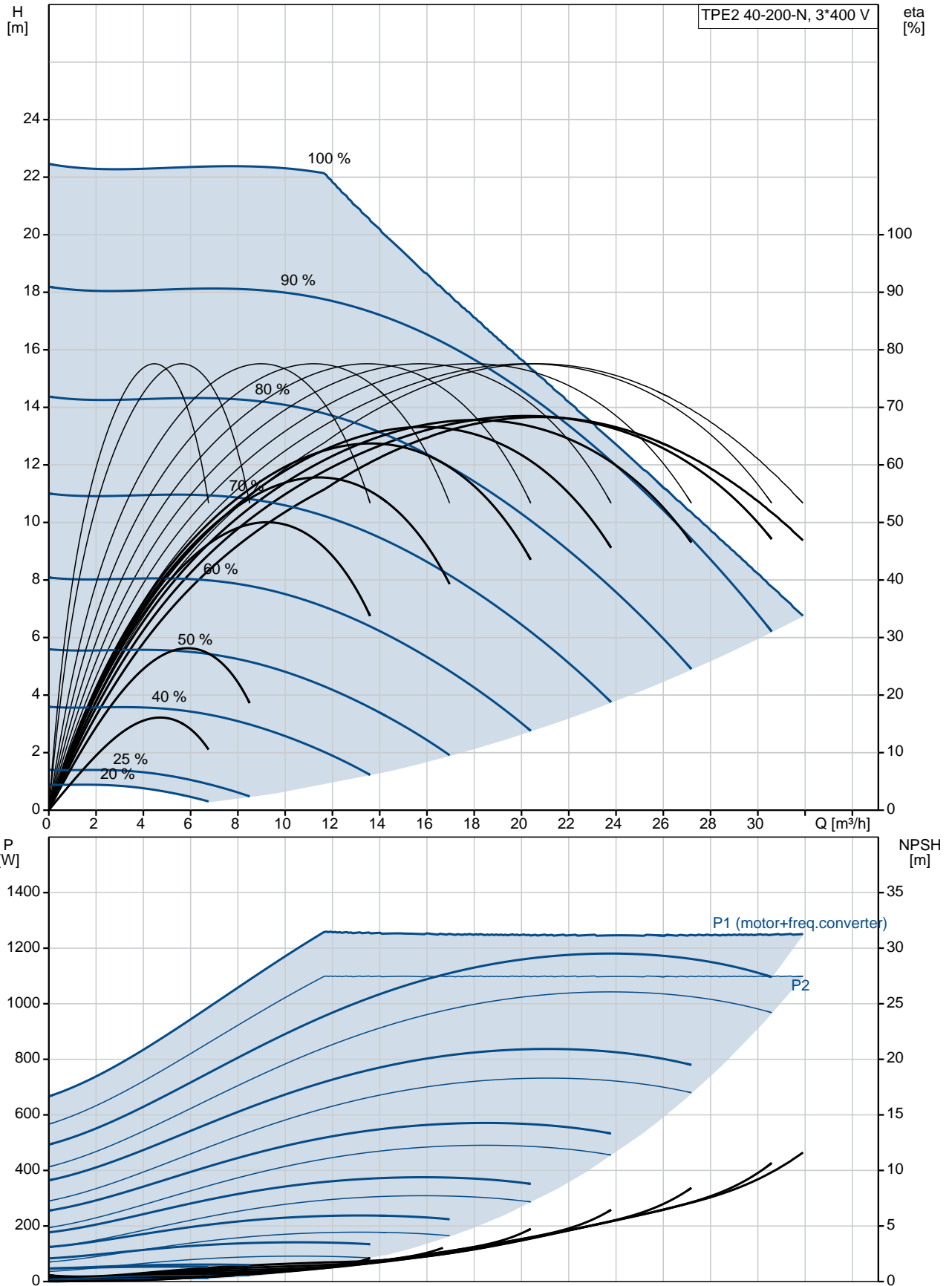

Description	Value
General information:	
Product name:	TPE2 40-200-N A-F-A-BQQE
Product No:	98437889
EAN number:	5711495010850
Technical:	
Pump speed on which pump data are based:	5000 rpm
Rated flow:	20.5 m ³ /h
Rated head:	14.9 m
Head max:	200 dm
Actual impeller diameter:	74 mm
Primary shaft seal:	BQQE
Curve tolerance:	ISO9906:2012 3B
Pump version:	A
Model:	A
Materials:	
Pump housing:	Cast iron
	EN-JL1040
	ASTM A48-40 B
Impeller:	Composite PES/PP 30% GF
Material code:	A
Installation:	
Range of ambient temperature:	-20 .. 50 °C
Maximum operating pressure:	10 bar
Flange standard:	DIN
Pipe connection:	DN 40
Pressure rating:	PN 6/10
Port-to-port length:	250 mm
Flange size for motor:	56C
Connect code:	F
Liquid:	
Pumped liquid:	Water
Liquid temperature range:	-25 .. 120 °C
Liquid temperature during operation:	20 °C
Density:	998.2 kg/m ³
Electrical data:	
Motor type:	80A
IE Efficiency class:	IE5
Rated power - P2:	1.1 kW
Mains frequency:	50 Hz
Rated voltage:	3 x 380-500 V
Rated current:	2.30-2.05 A
Cos phi - power factor:	0.88-0.74
Rated speed:	480-5900 rpm
Efficiency:	88.5%
Motor efficiency at full load:	88.5 %
Enclosure class (IEC 34-5):	IP55
Insulation class (IEC 85):	F
Motor protec:	YES
Motor No:	99138044
Controls:	
Control panel:	HMI200 - Standard
Function Module:	FM300 - Advanced
Frequency converter:	Built-in
Others:	
Minimum efficiency index, MEI =:	0.7
ErP status:	EuP Standalone/Prod.
Net weight:	24.5 kg

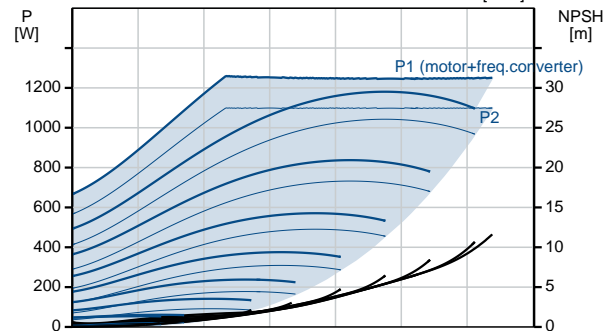
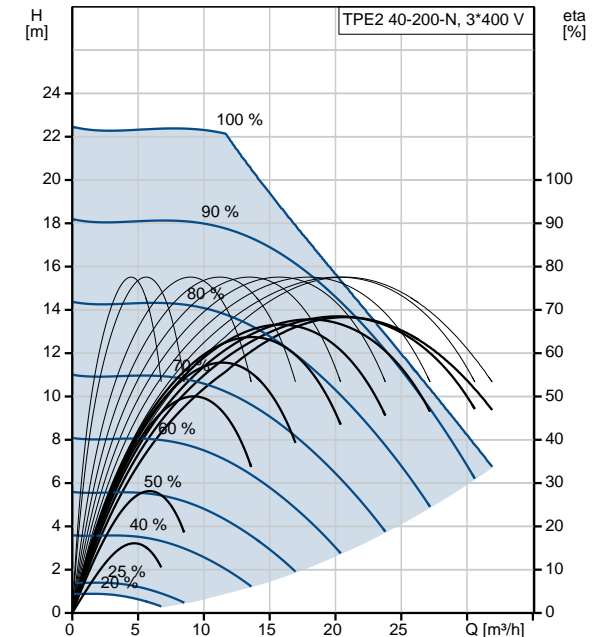



Company name:

Created by:

Phone:

Date: 21/12/2018

Description	Value
Gross weight:	32 kg
Shipping volume:	0.1 m ³
Config. file no:	98819255
Norwegian NRF no.:	9043496
Country of origin:	HU
Custom tariff no.:	84137051

98437889 TPE2 40-200-N A-F-A-BQQE 50 Hz

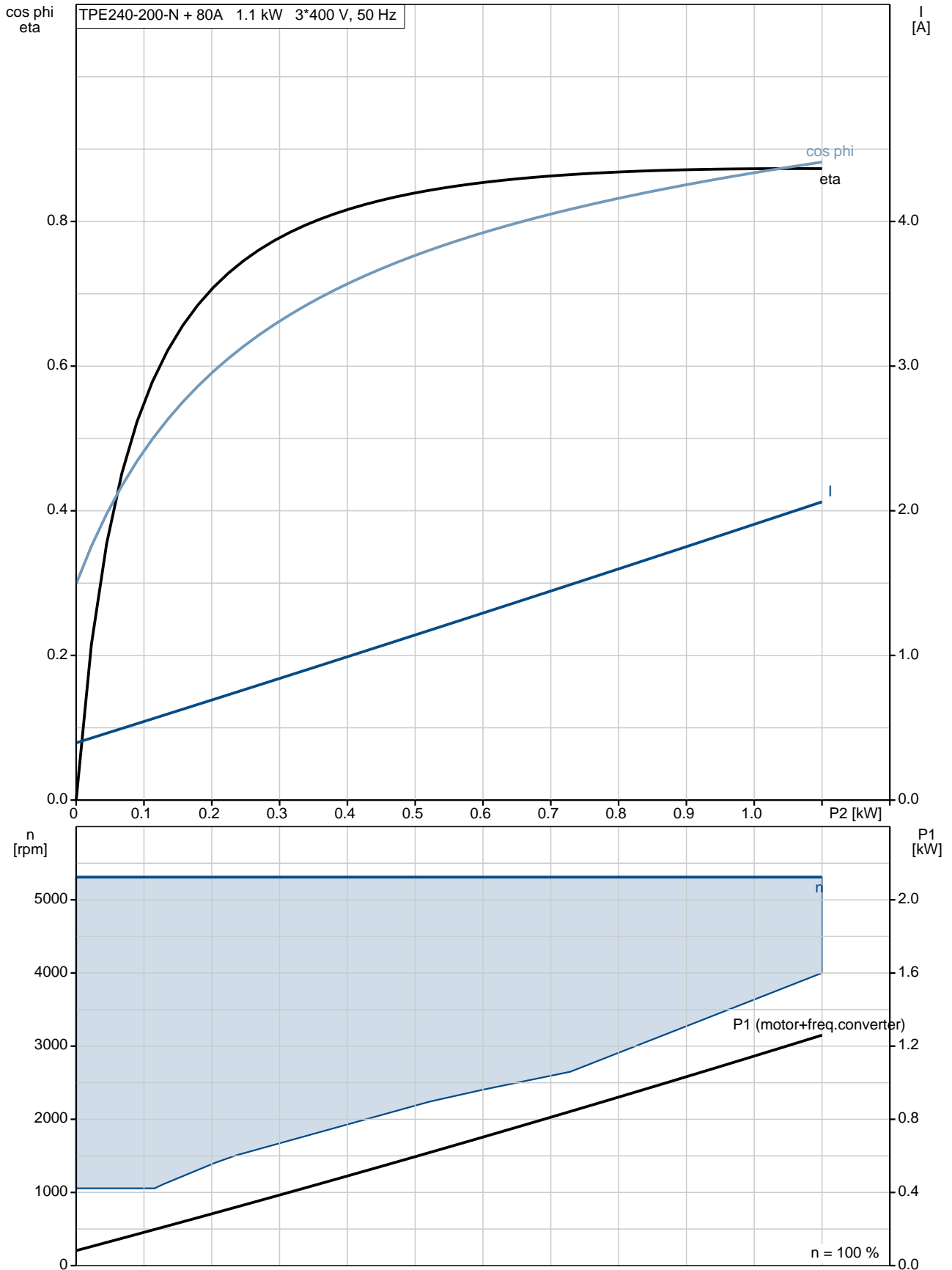

98437889 TPE2 40-200-N A-F-A-BQQE 50 Hz

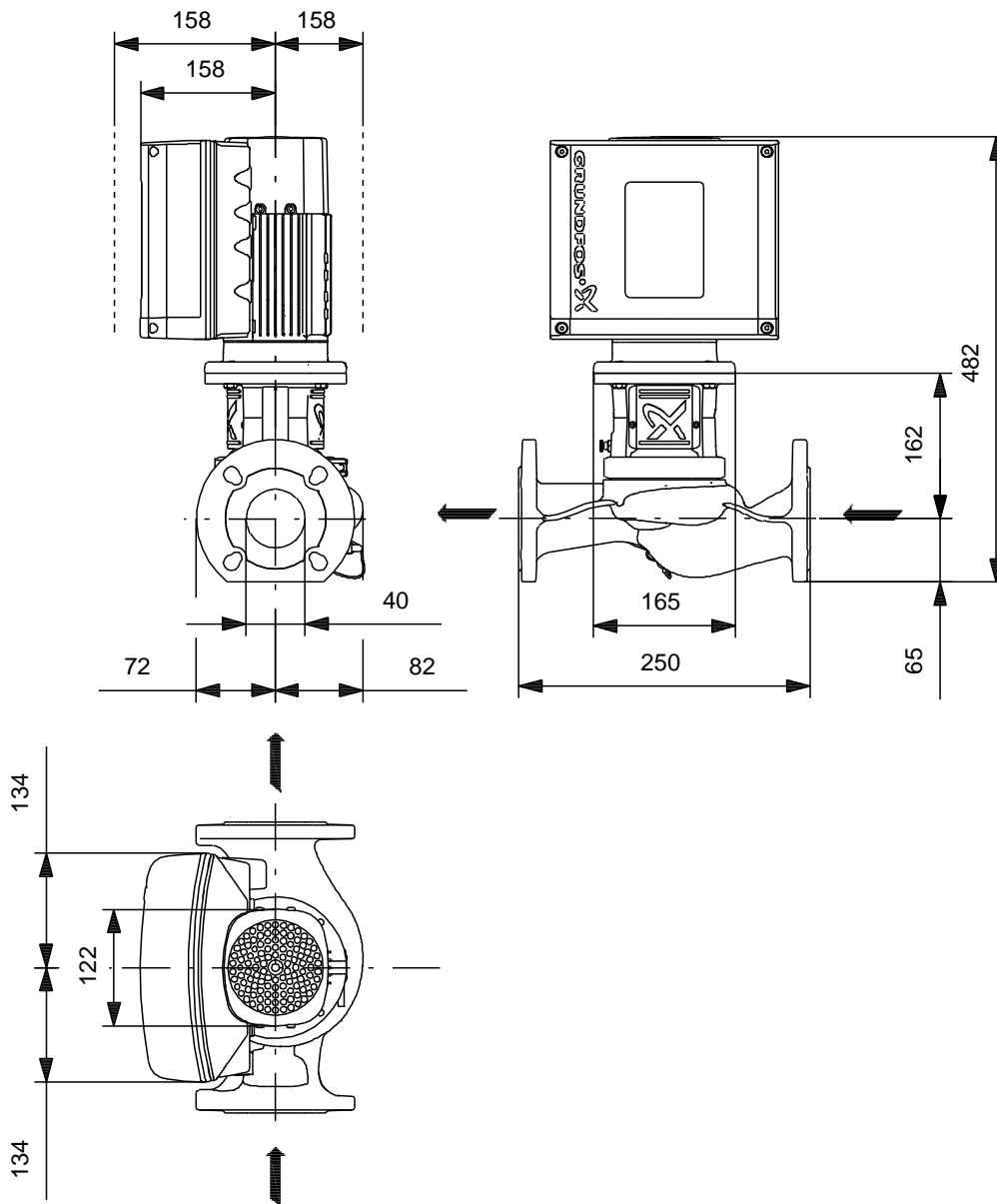

Note! All units are in [mm] unless others are stated.
Disclaimer: This simplified dimensional drawing does not show all details.

98437889 TPE2 40-200-N A-F-A-BQQE 50 Hz

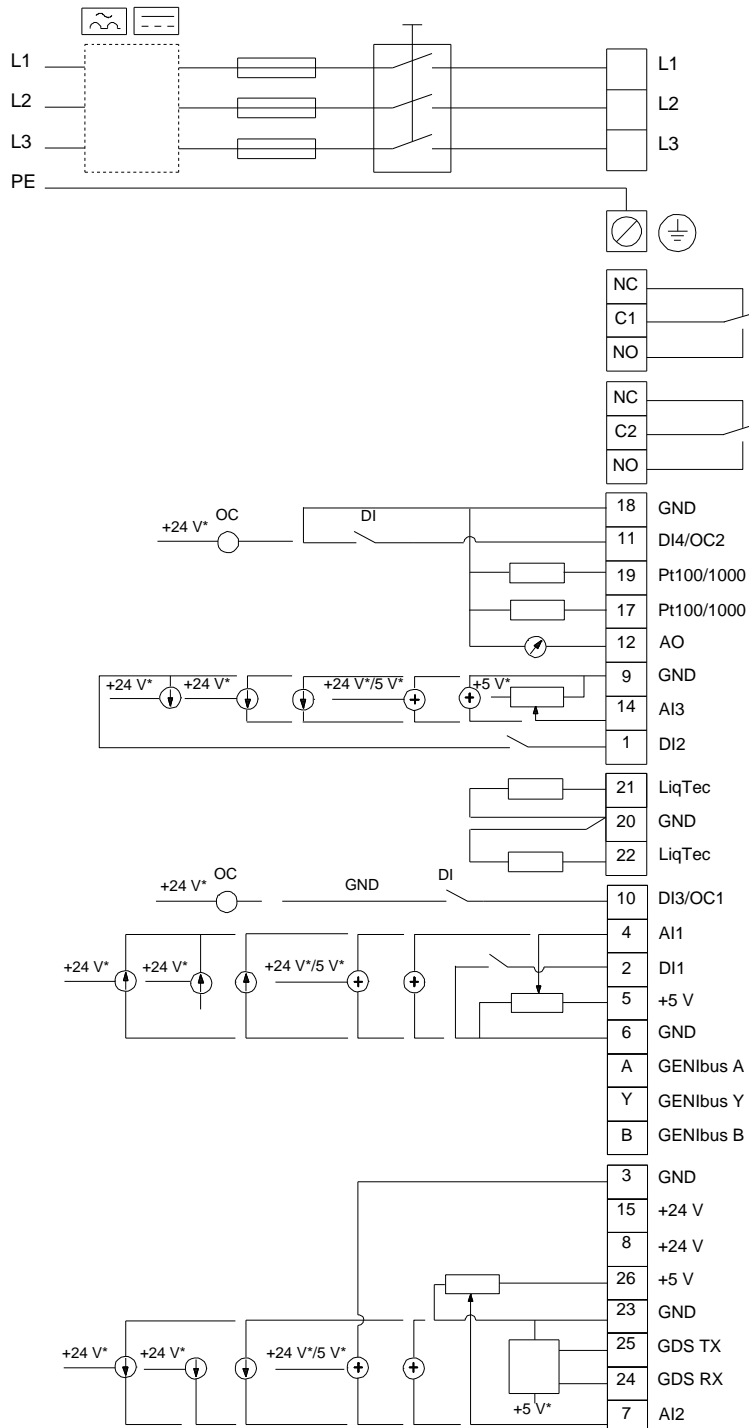

Note! All units are in [mm] unless others are stated.