

Qty.	Description
1	TPE2 80-150-N A-F-A-BQQE  Product No.: 98437604 Single-stage, close-coupled, volute pump with in-line suction and discharge ports of identical diameter. The pump is of the top-pull-out design, i.e. the power head (motor, pump head and impeller) can be removed for maintenance or service while the pump housing remains in the pipework. The shaft seal is according to EN 12756. Pipework connection is via PN 10 DIN flanges (EN 1092-2 and ISO 7005-2). The pump is fitted with a fan-cooled, permanent-magnet synchronous motor. The motor efficiency is classified as IE5 in accordance with IEC 60034-30-2. The motor includes a frequency converter and PI controller in the motor terminal box. This enables continuously variable control of the motor speed, which again enables adaptation of the performance to a given requirement. Controls: Frequency converter: Built-in Liquid: Pumped liquid: Water Liquid temperature range: -25 .. 120 °C Liquid temperature during operation: 20 °C Density: 998.2 kg/m ³ Technical: Pump speed on which pump data are based: 3400 rpm Rated flow: 44.5 m ³ /h Rated head: 9.9 m Actual impeller diameter: 90 mm Primary shaft seal: BQQE Curve tolerance: ISO9906:2012 3B Materials: Pump housing: Cast iron EN-JL1040 ASTM A48-40 B Impeller: Composite PES/PP 30% GF Installation: Range of ambient temperature: -20 .. 50 °C Maximum operating pressure: 10 bar Flange standard: DIN Pipe connection: DN 80 Pressure rating: PN 10 Port-to-port length: 360 mm Flange size for motor: 56C Electrical data: Motor type: 90SC IE Efficiency class: IE5 Rated power - P2: 1.5 kW

Qty.	Description
------	-------------

Mains frequency:	50 Hz
Rated voltage:	3 x 380-500 V
Rated current:	2.90-2.40 A
Cos phi - power factor:	0.92-0.85
Rated speed:	360-4000 rpm
Efficiency:	88.9%
Motor efficiency at full load:	88.9 %
Enclosure class (IEC 34-5):	IP55
Insulation class (IEC 85):	F

Others:

Minimum efficiency index, MEI =:	0.7
ErP status:	EuP Standalone/Prod.
Net weight:	36.4 kg
Gross weight:	45.2 kg
Shipping volume:	0.16 m ³
Norwegian NRF no.:	9043507
Country of origin:	HU
Custom tariff no.:	84137051

98437604 TPE2 80-150-N A-F-A-BQQE 50 Hz

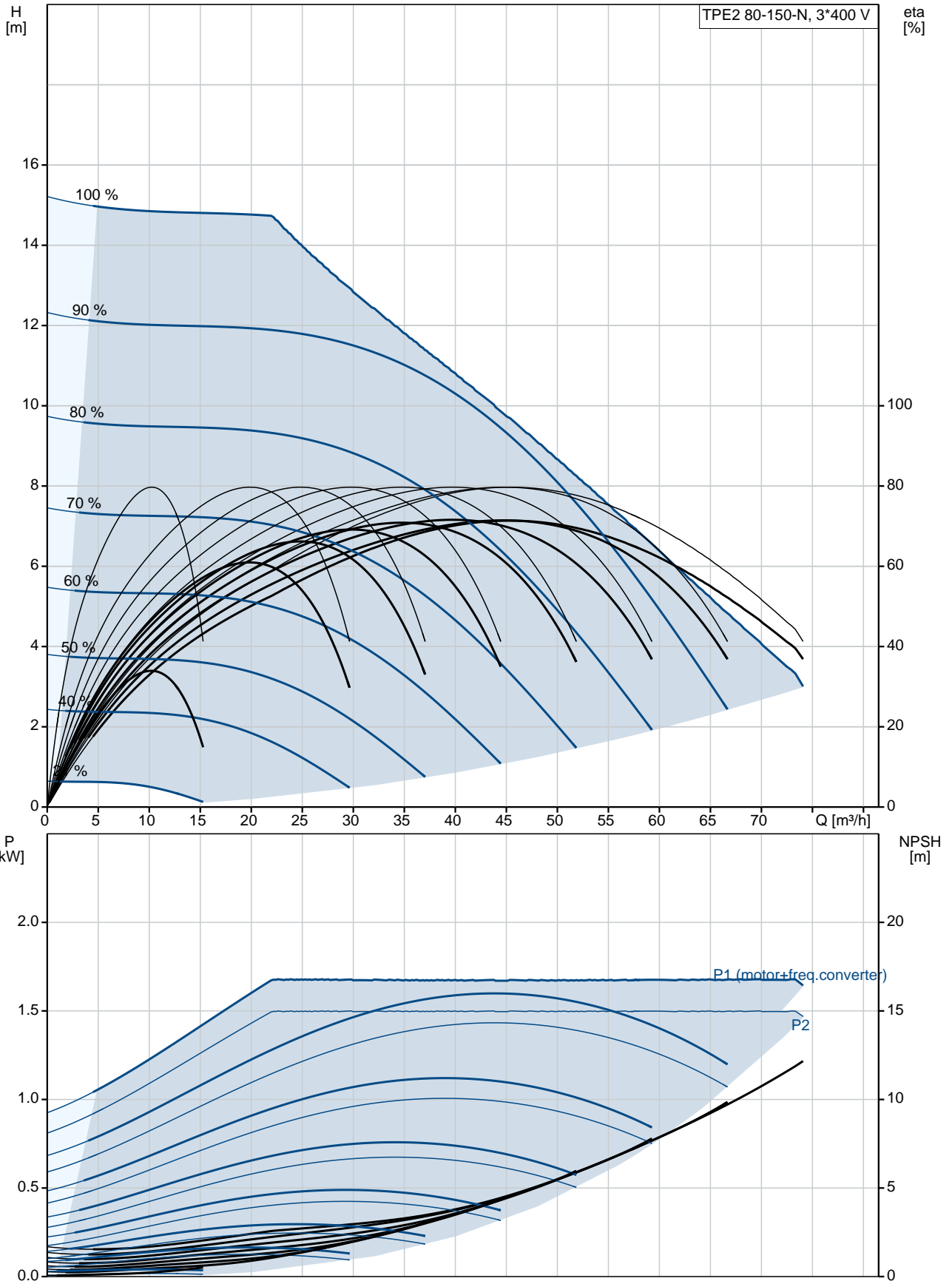

Description	Value
General information:	
Product name:	TPE2 80-150-N A-F-A-BQQE
Product No:	98437604
EAN number:	5711495007614
Technical:	
Pump speed on which pump data are based:	3400 rpm
Rated flow:	44.5 m ³ /h
Rated head:	9.9 m
Head max:	150 dm
Actual impeller diameter:	90 mm
Primary shaft seal:	BQQE
Curve tolerance:	ISO9906:2012 3B
Pump version:	A
Model:	A
Materials:	
Pump housing:	Cast iron
	EN-JL1040
	ASTM A48-40 B
Impeller:	Composite PES/PP 30% GF
Material code:	A
Installation:	
Range of ambient temperature:	-20 .. 50 °C
Maximum operating pressure:	10 bar
Flange standard:	DIN
Pipe connection:	DN 80
Pressure rating:	PN 10
Port-to-port length:	360 mm
Flange size for motor:	56C
Connect code:	F
Liquid:	
Pumped liquid:	Water
Liquid temperature range:	-25 .. 120 °C
Liquid temperature during operation:	20 °C
Density:	998.2 kg/m ³
Electrical data:	
Motor type:	90SC
IE Efficiency class:	IE5
Rated power - P2:	1.5 kW
Mains frequency:	50 Hz
Rated voltage:	3 x 380-500 V
Rated current:	2.90-2.40 A
Cos phi - power factor:	0.92-0.85
Rated speed:	360-4000 rpm
Efficiency:	88.9%
Motor efficiency at full load:	88.9 %
Enclosure class (IEC 34-5):	IP55
Insulation class (IEC 85):	F
Motor protec:	YES
Motor No:	99138020
Controls:	
Control panel:	HMI200 - Standard
Function Module:	FM300 - Advanced
Frequency converter:	Built-in
Others:	
Minimum efficiency index, MEI =:	0.7
ErP status:	EuP Standalone/Prod.
Net weight:	36.4 kg

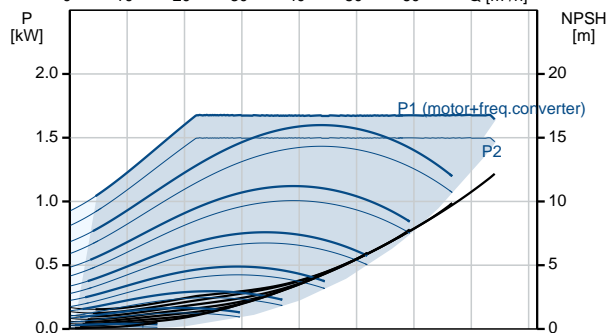
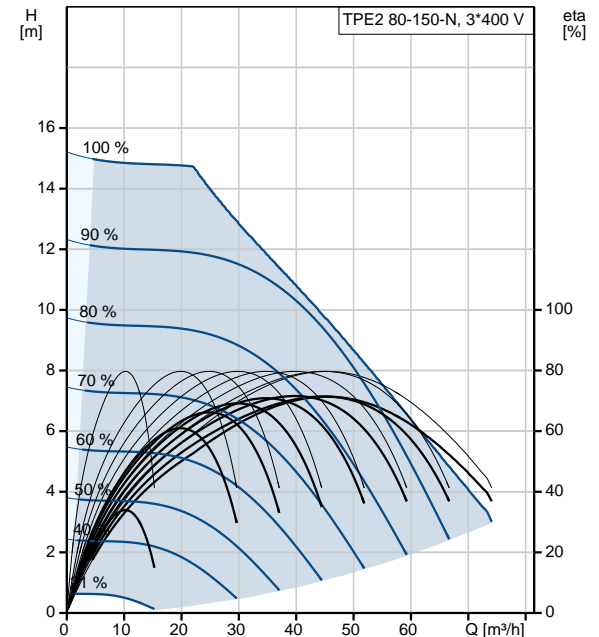



Company name:

Created by:

Phone:

Date:

21/12/2018

Description	Value
Gross weight:	45.2 kg
Shipping volume:	0.16 m ³
Config. file no:	98819269
Norwegian NRF no.:	9043507
Country of origin:	HU
Custom tariff no.:	84137051

98437604 TPE2 80-150-N A-F-A-BQQE 50 Hz

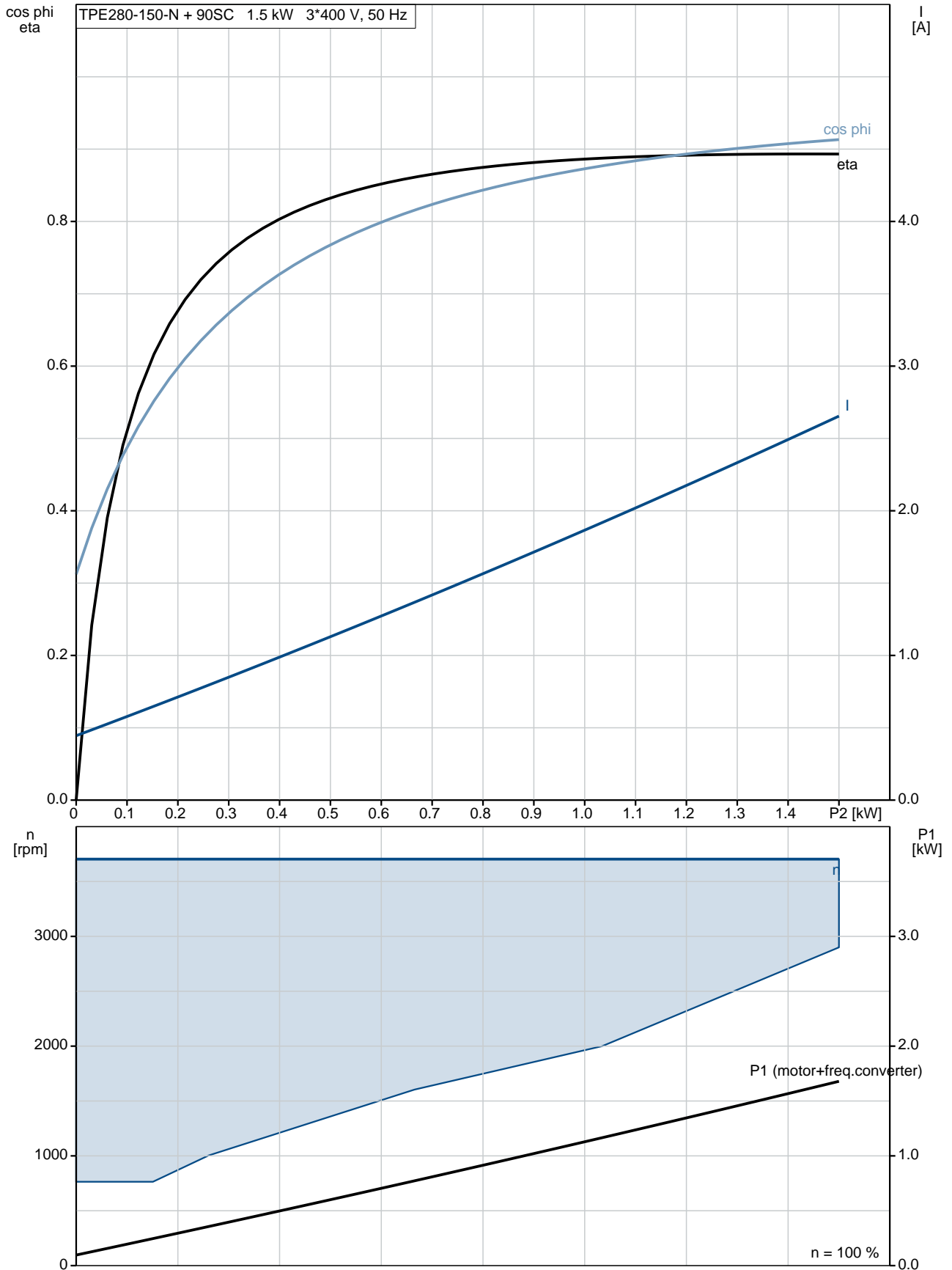

98437604 TPE2 80-150-N A-F-A-BQQE 50 Hz

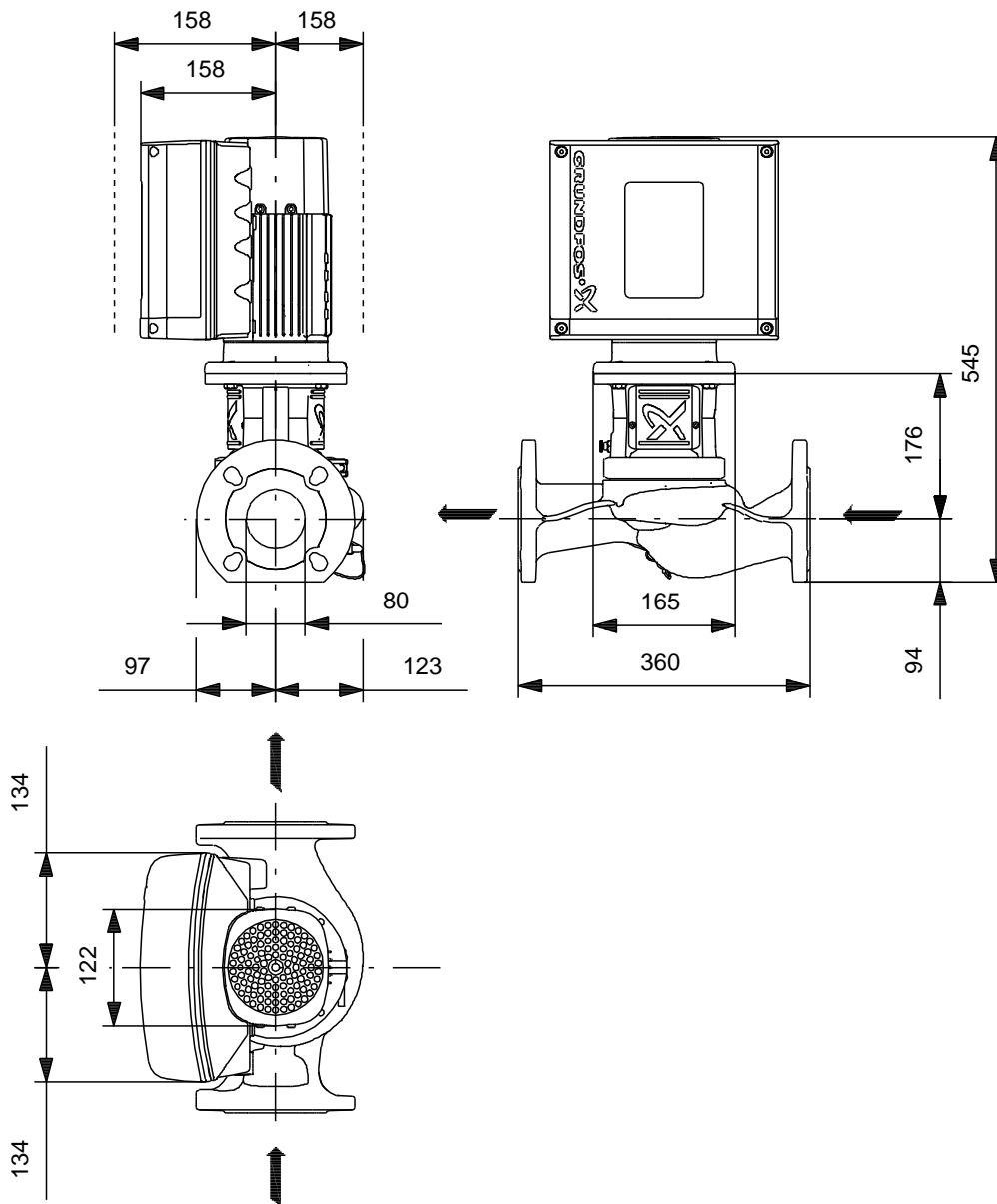

Note! All units are in [mm] unless others are stated.
Disclaimer: This simplified dimensional drawing does not show all details.

98437604 TPE2 80-150-N A-F-A-BQQE 50 Hz

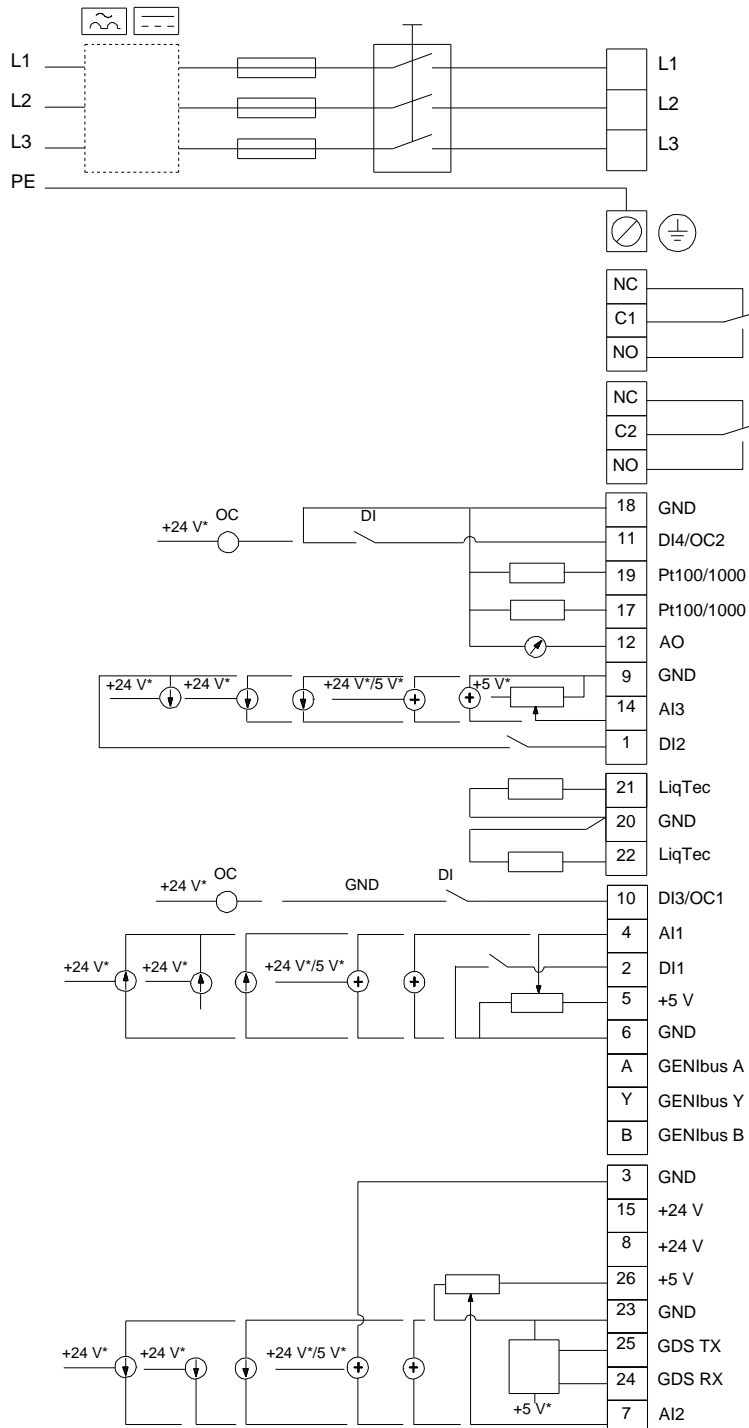

Note! All units are in [mm] unless others are stated.