

Qty.	Description
------	-------------

1	<b>CRIE 1-17 A-CA-A-E-HQQE</b>
---	--------------------------------



Note! Product picture may differ from actual product

Product No.: [98389347](#)

Vertical, multistage centrifugal pump with inlet and outlet ports on same the level (inline). Pump materials in contact with the liquid are in stainless steel. A cartridge shaft seal ensures high reliability, safe handling, and easy access and service. Power transmission is via a rigid split coupling. Pipe connection is via FlexiClamps.

The pump is fitted with a 1-phase, fan-cooled, permanent-magnet, synchronous motor.

The motor efficiency is classified as IE5 in accordance with IEC 60034-30-2.

The motor includes a frequency converter and PI controller in the motor terminal box. This enables continuously variable control of the motor speed, which again enables adaptation of the performance to a given requirement. An operating panel on the motor terminal box enables setting of required setpoint as well as setting of pump to "Min." or "Max." operation or to "Stop". The Grundfos Eye indicator on the operating panel provides visual indication of pump status:

- "Power on": Motor is running (rotating green indicator lights) or not running (permanently green indicator lights)
- "Warning": Motor is still running (rotating yellow indicator lights) or has stopped (permanently yellow indicator lights)
- "Alarm": Motor has stopped (flashing red indicator lights).

Communication with the pump is possible by means of Grundfos GO Remote (accessory). The remote control enables further settings as well as reading out of a number of parameters such as "Actual value", "Speed", "Power input" and total "Power consumption".

The terminal box has a number of inputs and outputs enabling the motor to be used in advanced applications where many inputs and outputs are required:

- two dedicated digital inputs
- three analog inputs, 0(4)-20 mA, 0-5 V, 0-10 V, 0.5 - 3.5 V
- 5 V voltage supply to potentiometer and sensor
- one analog output, 0-10 V, 0(4)-20 mA
- two configurable digital inputs or open-collector outputs
- two Pt100/Pt1000 inputs
- LiqTec, dry-running protection sensor input
- Grundfos Digital Sensor input and output
- 24 V voltage supply for sensors
- two signal-relay outputs (potential-free contacts)
- GENibus connection
- interface for Grundfos CIM fieldbus module.

**Controls:**

Frequency converter: Built-in

Pressure sensor: N

**Liquid:**

Pumped liquid: Water

Qty.	Description
	<p>Liquid temperature range: -20 .. 120 °C            Liquid temperature during operation: 20 °C            Density: 998.2 kg/m<sup>3</sup></p> <p><b>Technical:</b>            Pump speed on which pump data are based: 3350 rpm            Rated flow: 2.2 m<sup>3</sup>/h            Rated head: 100.3 m            Pump orientation: Vertical            Shaft seal arrangement: Single            Code for shaft seal: HQQE            Approvals on nameplate: CE, EAC, ACS            Curve tolerance: ISO9906:2012 3B</p> <p><b>Materials:</b>            Base: Stainless steel                      EN 1.4408                      AISI 316            Impeller: Stainless steel                      EN 1.4301                      AISI 304            Bearing: SIC</p> <p><b>Installation:</b>            Maximum ambient temperature: 50 °C            Maximum operating pressure: 25 bar            Max pressure at stated temp: 25 bar / 120 °C              25 bar / -20 °C            Type of connection: FlexiClamp            Size of inlet connection: DN 32              1 1/4 inch            Size of outlet connection: DN 32              1 1/4 inch            Pressure rating for pipe connection: PN 25            Flange size for motor: FT115</p> <p><b>Electrical data:</b>            Motor standard: IEC            Motor type: 90SC            IE Efficiency class: IE5            Rated power - P2: 1.5 kW            Power (P2) required by pump: 1.5 kW            Mains frequency: 50 Hz            Rated voltage: 1 x 200-240 V            Rated current: 9.10-7.60 A            Cos phi - power factor: 0.99            Rated speed: 360-4000 rpm            Efficiency: 87.4%            Motor efficiency at full load: 87.4 %            Enclosure class (IEC 34-5): IP55            Insulation class (IEC 85): F</p> <p><b>Others:</b>            Minimum efficiency index, MEI <math>\hat{\alpha}\%</math>: 0.70            Net weight: 29.7 kg            Gross weight: 35.3 kg            Shipping volume: 0.173 m<sup>3</sup>            Country of origin: GB            Custom tariff no.: 84137075</p>

## 98389347 CRIE 1-17 A-CA-A-E-HQQE 50 Hz

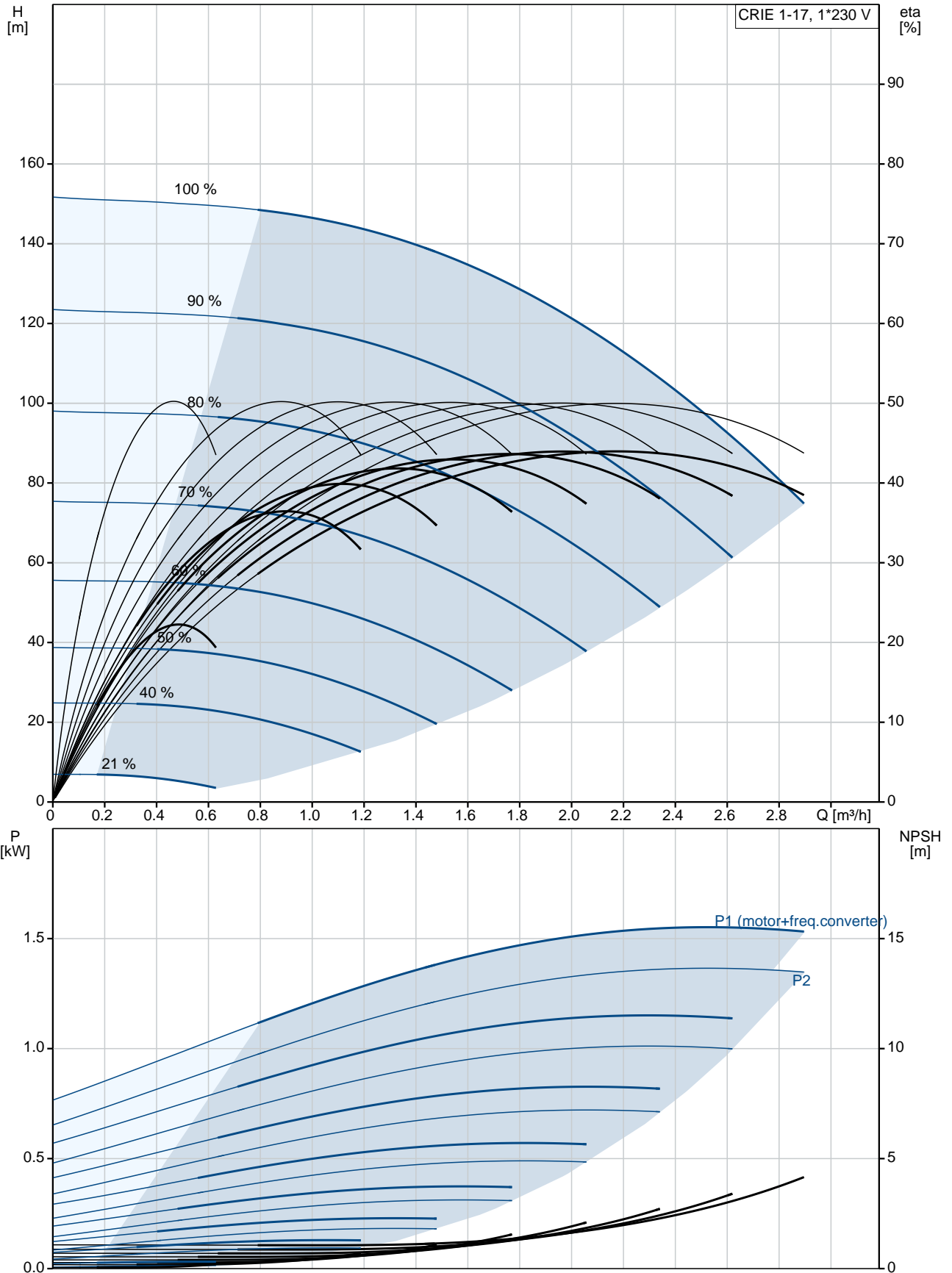

Description	Value
<b>General information:</b>	
Product name:	CRIE 1-17 A-CA-A-E-HQQE
Product No:	98389347
EAN number:	5711494176137
Price:	2.300,00 GBP
<b>Technical:</b>	
Pump speed on which pump data are based:	3350 rpm
Rated flow:	2.2 m <sup>3</sup> /h
Rated head:	100.3 m
Head max:	148.6 m
Stages:	17
Impellers:	17
Number of reduced-diameter impellers:	0
Low NPSH:	N
Pump orientation:	Vertical
Shaft seal arrangement:	Single
Code for shaft seal:	HQQE
Approvals on nameplate:	CE, EAC, ACS
Curve tolerance:	ISO9906:2012 3B
Pump version:	A
Model:	A
<b>Materials:</b>	
Base:	Stainless steel EN 1.4408 AISI 316
Impeller:	Stainless steel EN 1.4301 AISI 304
Material code:	A
Code for rubber:	E
Bearing:	SIC
<b>Installation:</b>	
Maximum ambient temperature:	50 °C
Maximum operating pressure:	25 bar
Max pressure at stated temp:	25 bar / 120 °C 25 bar / -20 °C
Type of connection:	FlexiClamp
Size of inlet connection:	DN 32 1 1/4 inch
Size of outlet connection:	DN 32 1 1/4 inch
Pressure rating for pipe connection:	PN 25
Flange size for motor:	FT115
Connect code:	CA
<b>Liquid:</b>	
Pumped liquid:	Water
Liquid temperature range:	-20 .. 120 °C
Liquid temperature during operation:	20 °C
Density:	998.2 kg/m <sup>3</sup>
<b>Electrical data:</b>	
Motor standard:	IEC
Motor type:	90SC
IE Efficiency class:	IE5
Rated power - P2:	1.5 kW
Power (P2) required by pump:	1.5 kW
Mains frequency:	50 Hz
Rated voltage:	1 x 200-240 V

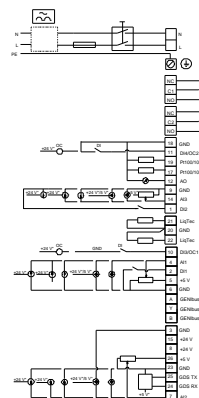
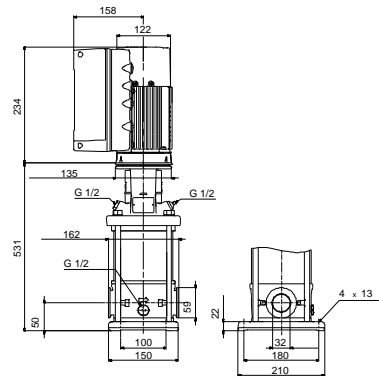
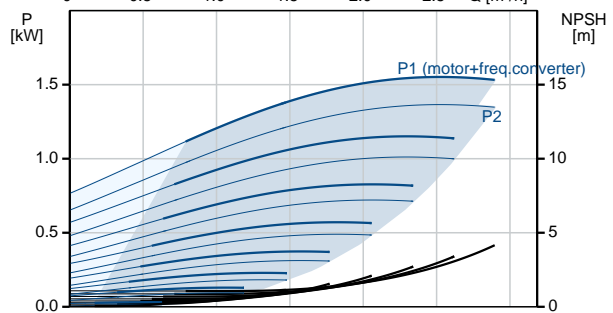
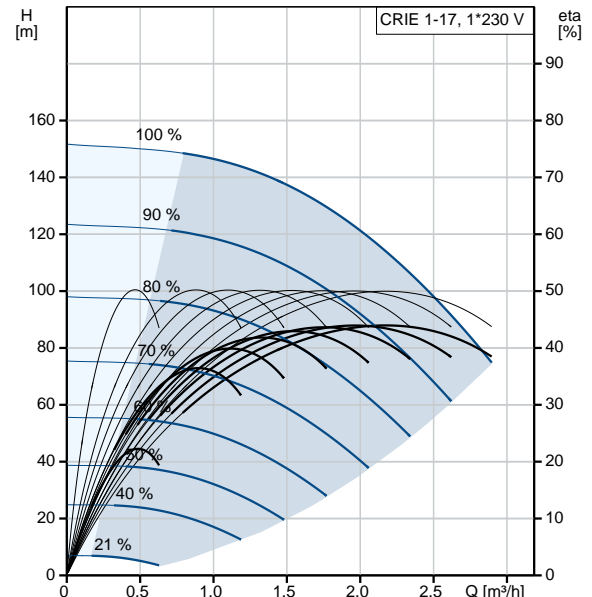



Company name:

Created by:

Phone:

Date:

19/03/2019

Description	Value
Rated current:	9.10-7.60 A
Cos phi - power factor:	0.99
Rated speed:	360-4000 rpm
Efficiency:	87.4%
Motor efficiency at full load:	87.4 %
Enclosure class (IEC 34-5):	IP55
Insulation class (IEC 85):	F
Motor protec:	YES
Motor No:	98190188
<b>Controls:</b>	
Control panel:	Standard
Function Module:	FM300 - Advanced
Frequency converter:	Built-in
Pressure sensor:	N
<b>Others:</b>	
Minimum efficiency index, MEI %:	0.70
Net weight:	29.7 kg
Gross weight:	35.3 kg
Shipping volume:	0.173 m <sup>3</sup>
Country of origin:	GB
Custom tariff no.:	84137075

## 98389347 CRIE 1-17 A-CA-A-E-HQQE 50 Hz

