

Position	Qty.	Description
	1	<p>TP 40-90/2 A-F-A-BQQE</p>  <p>Product No.: 98346609</p> <p>Single-stage, close-coupled, volute pump with in-line suction and discharge ports of identical diameter. The pump is of the top-pull-out design, i.e. the power head (motor, pump head and impeller) can be removed for maintenance or service while the pump housing remains in the pipework.</p> <p>The pump is fitted with an unbalanced rubber bellows seal. The shaft seal is according to EN 12756. Pipework connection is via PN 6/10 DIN flanges (EN 1092-2 and ISO 7005-2).</p> <p>The pump is fitted with a fan-cooled asynchronous motor.</p> <p>Liquid: Pumped liquid: Water Liquid temperature range: -25 .. 120 °C Liquid temperature during operation: 20 °C Density: 998.2 kg/m³</p> <p>Technical: Speed for pump data: 2865 rpm Rated flow: 9.48 m³/h Rated head: 7.01 m Actual impeller diameter: 89 mm Primary shaft seal: BQQE Curve tolerance: ISO9906:2012 3B</p> <p>Materials: Pump housing: Cast iron EN-JL1030 ASTM A48-30 B Impeller: Composite PES/PP 30% GF</p> <p>Installation: Range of ambient temperature: -30 .. 40 °C Maximum operating pressure: 10 bar Flange standard: DIN Pipe connection: DN 40 Pump inlet: DN 40 Pump outlet: DN 40 Pressure rating: PN 6/10 Port-to-port length: 250 mm Flange size for motor: FT85</p> <p>Electrical data: Motor type: 71B IE Efficiency class: NA Rated power - P2: 0.37 kW Power (P2) required by pump: 0.37 kW Mains frequency: 50 Hz Rated voltage: 1 x 220-230/240 V Rated current: 2,95/2,70 A</p>



Company name:

Created by:

Phone:

Date:

19/12/2017

Position	Qty.	Description
		Starting current: 280 % Cos phi - power factor: 0,99 Rated speed: 2770 rpm Motor efficiency at full load: 60.0-56.0 % Number of poles: 2 Enclosure class (IEC 34-5): 55 Dust/Jetting Insulation class (IEC 85): F Others: Minimum efficiency index, MEI : 0.70 ErP status: EuP Standalone/Prod. Net weight: 14.6 kg Gross weight: 16.6 kg Shipping volume: 0.04 m ³ Danish VVS No.: VVS NO 381802090

98346609 TP 40-90/2 50 Hz

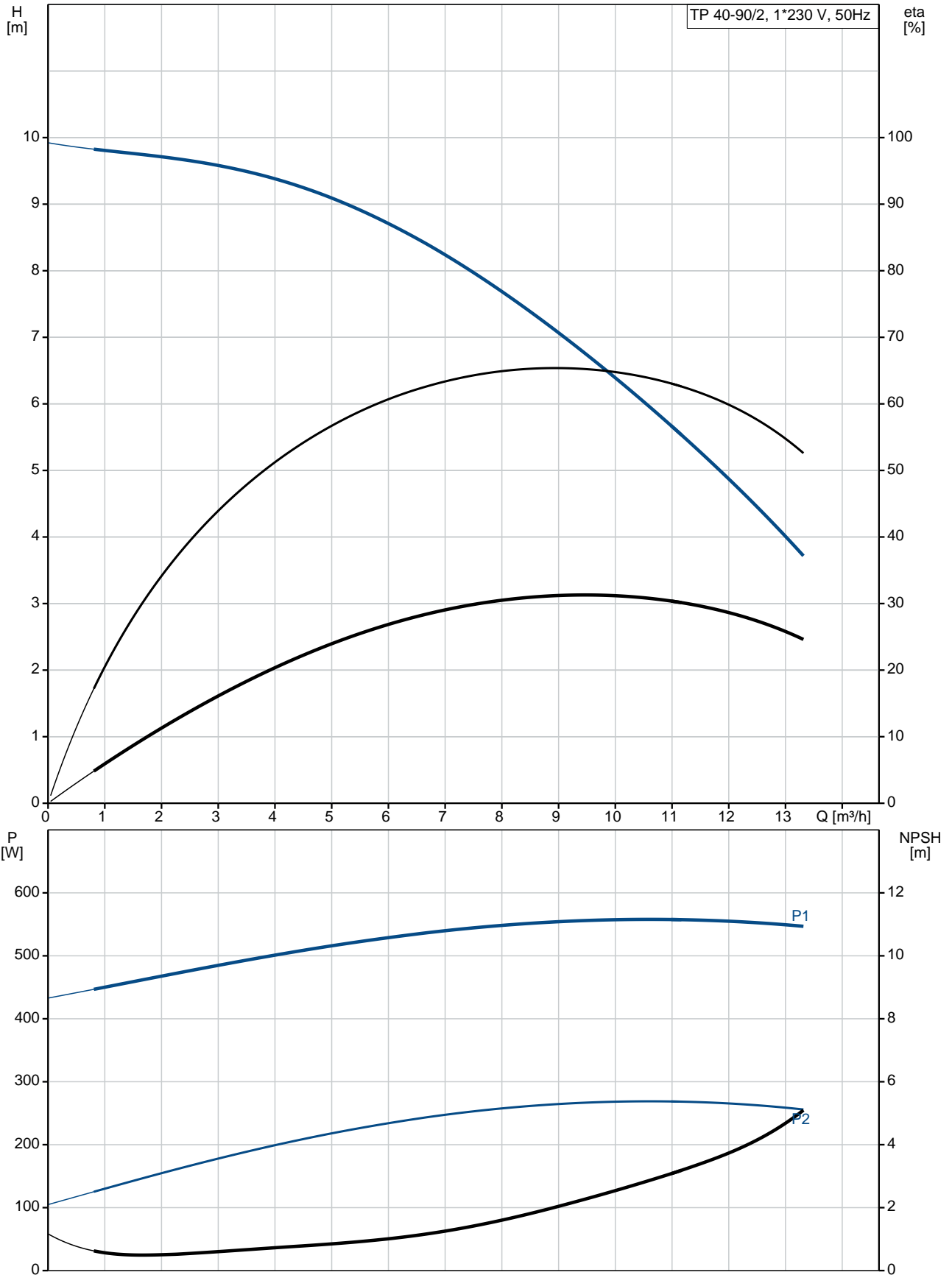

Description	Value
General information:	
Product name:	TP 40-90/2 A-F-A-BQQE
Product No:	98346609
EAN number:	5711493380108
Technical:	
Speed for pump data:	2865 rpm
Rated flow:	9.48 m ³ /h
Rated head:	7.01 m
Head max:	90 dm
Actual impeller diameter:	89 mm
Primary shaft seal:	BQQE
Curve tolerance:	ISO9906:2012 3B
Pump version:	A
Model:	B
Materials:	
Pump housing:	Cast iron EN-JL1030 ASTM A48-30 B
Impeller:	Composite PES/PP 30% GF
Material code:	A
Installation:	
Range of ambient temperature:	-30 .. 40 °C
Maximum operating pressure:	10 bar
Flange standard:	DIN
Connect code:	F
Pipe connection:	DN 40
Pump inlet:	DN 40
Pump outlet:	DN 40
Pressure rating:	PN 6/10
Port-to-port length:	250 mm
Flange size for motor:	FT85
Liquid:	
Pumped liquid:	Water
Liquid temperature range:	-25 .. 120 °C
Liquid temperature during operation:	20 °C
Density:	998.2 kg/m ³
Electrical data:	
Motor type:	71B
IE Efficiency class:	NA
Rated power - P2:	0.37 kW
Power (P2) required by pump:	0.37 kW
Mains frequency:	50 Hz
Rated voltage:	1 x 220-230/240 V
Rated current:	2,95/2,70 A
Starting current:	280 %
Cos phi - power factor:	0,99
Rated speed:	2770 rpm
Motor efficiency at full load:	60.0-56.0 %
Number of poles:	2
Enclosure class (IEC 34-5):	55 Dust/Jetting
Insulation class (IEC 85):	F
Motor protec:	PTO
Motor No:	85215102

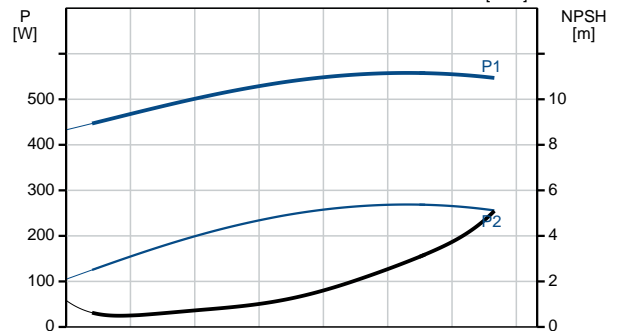
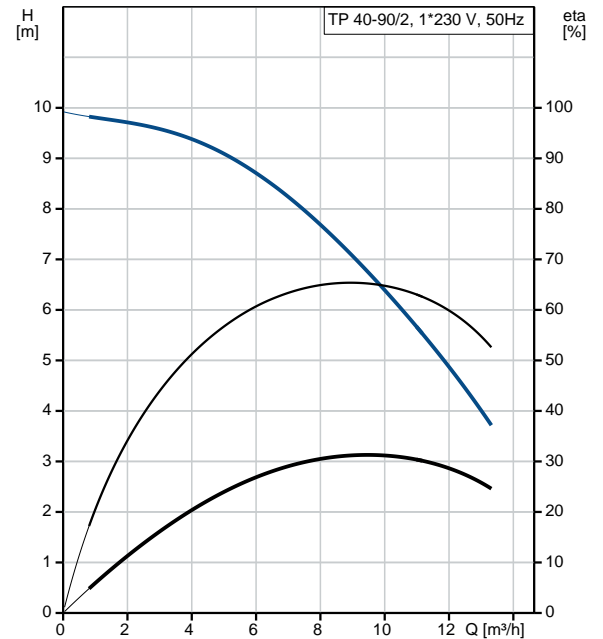



Company name:

Created by:

Phone:

Date:

19/12/2017

Description	Value
Others:	
Minimum efficiency index, MEI :	0.70
ErP status:	EuP Standalone/Prod.
Net weight:	14.6 kg
Gross weight:	16.6 kg
Shipping volume:	0.04 m ³
Danish VVS No.:	VVS NO 381802090

98346609 TP 40-90/2 50 Hz

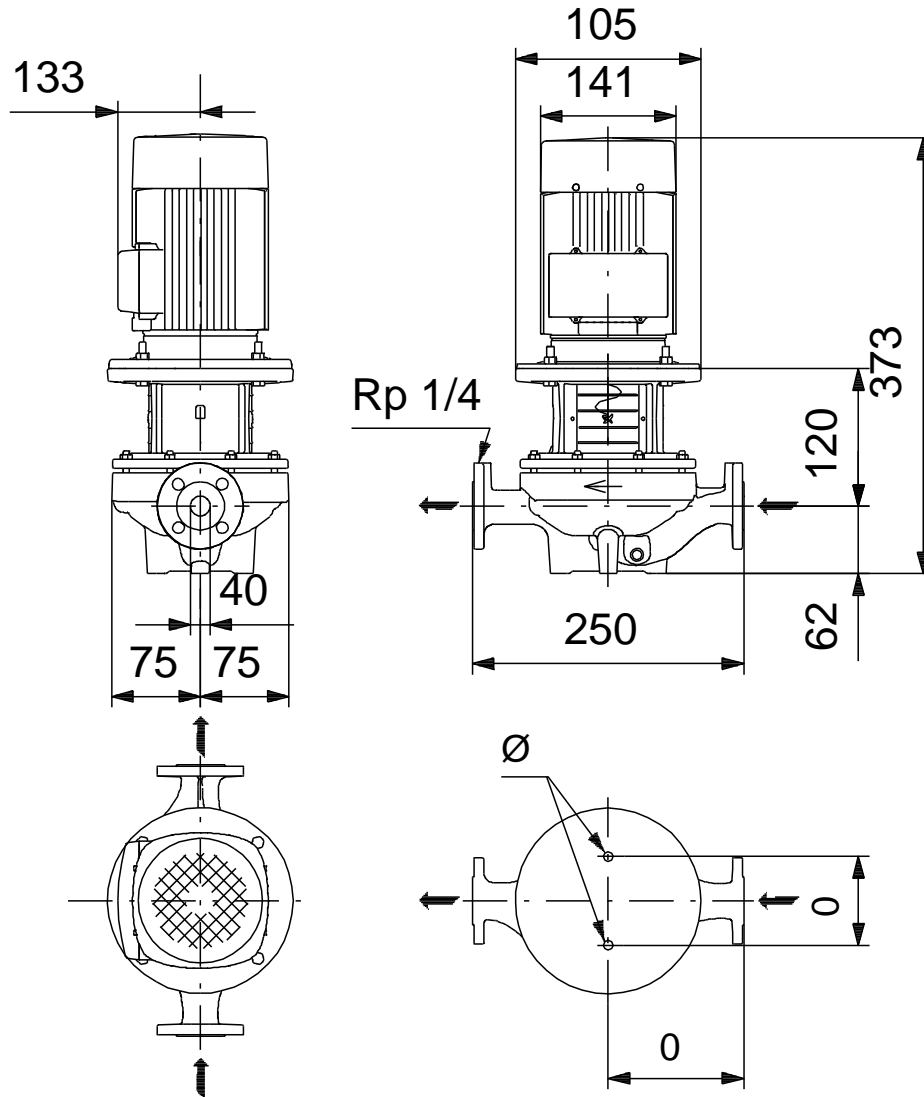

Note! All units are in [mm] unless others are stated.
Disclaimer: This simplified dimensional drawing does not show all details.

98346609 TP 40-90/2 50 Hz

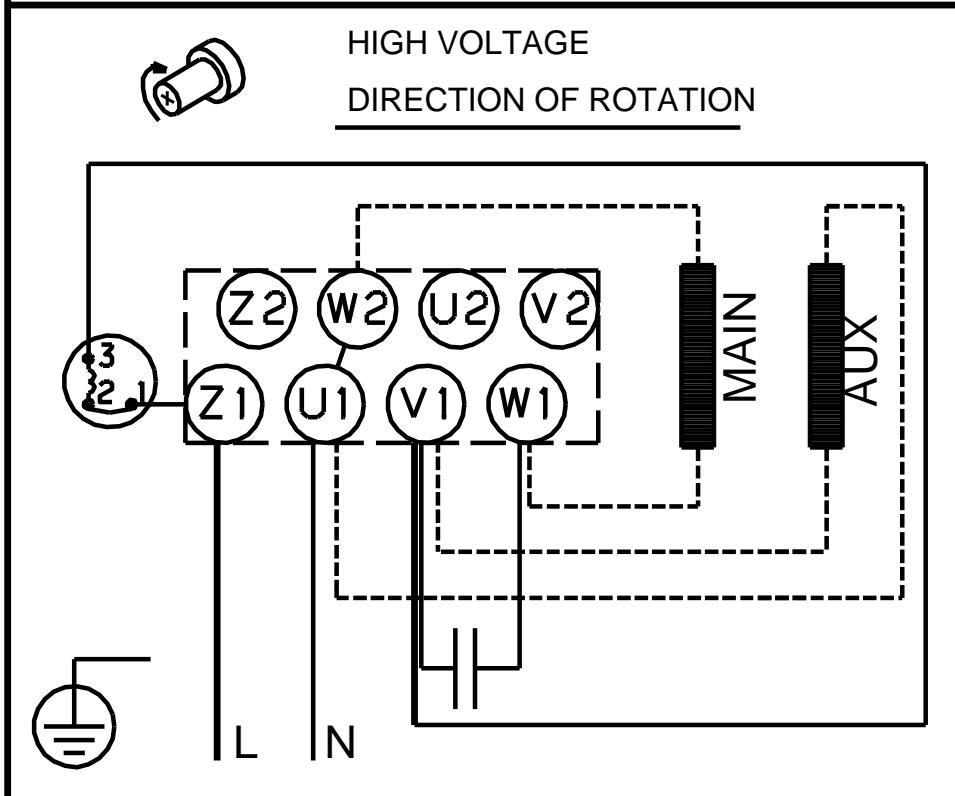
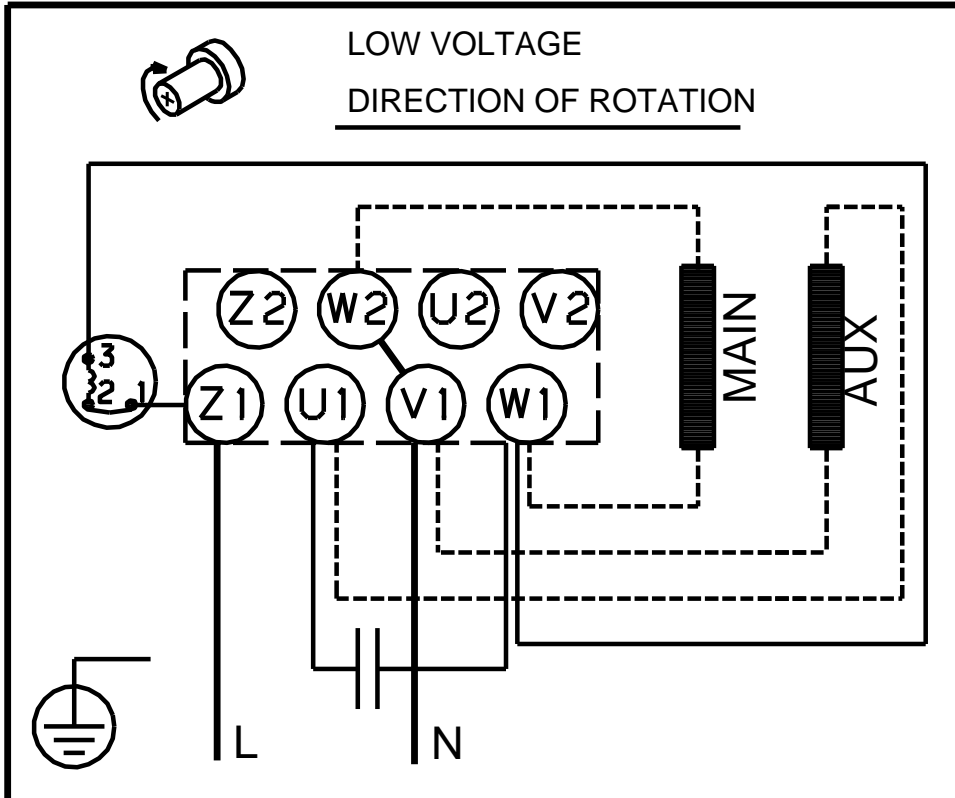

Note! All units are in [mm] unless others are stated.