

Position	Qty.	Description
	1	<p><b>TP 40-120/2 B A-F-Z-BQQE</b></p>  <p>Note! Product picture may differ from actual product</p> <p>Product No.: <a href="#">97822677</a></p> <p>Single-stage, close-coupled, volute pump with in-line suction and discharge ports of identical diameter. The pump is of the top-pull-out design, i.e. the power head (motor, pump head and impeller) can be removed for maintenance or service while the pump housing remains in the pipework.</p> <p>The pump is fitted with an unbalanced rubber bellows seal. The shaft seal is according to EN 12756. Pipework connection is via PN 6/10 DIN flanges (EN 1092-2 and ISO 7005-2).</p> <p>The pump is fitted with a fan-cooled asynchronous motor.</p> <p><b>Liquid:</b>  Pumped liquid: Water  Liquid temperature range: -25 .. 120 °C  Liquid temperature during operation: 20 °C  Density: 998.2 kg/m<sup>3</sup></p> <p><b>Technical:</b>  Speed for pump data: 2850 rpm  Rated flow: 11.4 m<sup>3</sup>/h  Rated head: 7.4 m  Primary shaft seal: BQQE  Curve tolerance: ISO9906:2012 3B</p> <p><b>Materials:</b>  Pump housing: Bronze  DIN W.-Nr. 2.1050  ASTM B505-C90700  Impeller: Stainless steel  DIN W.-Nr. 1.4301  AISI 304</p> <p><b>Installation:</b>  Range of ambient temperature: -30 .. 40 °C  Maximum operating pressure: 10 bar  Flange standard: DIN  Pipe connection: DN 40  Pressure stage: PN 6/10  Port-to-port length: 250 mm  Flange size for motor: FT85</p> <p><b>Electrical data:</b>  Motor type: 71A  IE Efficiency class: IE3  Rated power - P2: 0.37 kW  Power (P2) required by pump: 0.37 kW  Mains frequency: 50 Hz  Rated voltage: 3 x 220-240D/380-415Y V</p>

Position	Qty.	Description
		<p>Rated current: 1,74/1,00 A</p> <p>Starting current: 490-530 %</p> <p>Cos phi - power factor: 0,80-0,70</p> <p>Rated speed: 2850-2880 rpm</p> <p>Efficiency: IE3 73,8%</p> <p>Motor efficiency at full load: 73.8 %</p> <p>Motor efficiency at 3/4 load: 79.0 %</p> <p>Motor efficiency at 1/2 load: 75.5 %</p> <p>Number of poles: 2</p> <p>Enclosure class (IEC 34-5): 55 Dust/Jetting</p> <p>Insulation class (IEC 85): F</p> <p><b>Others:</b></p> <p>Minimum efficiency index, MEI : 0.70</p> <p>ErP status: EuP Standalone/Prod.</p> <p>Net weight: 24.2 kg</p> <p>Gross weight: 27.7 kg</p> <p>Shipping volume: 0.06 m<sup>3</sup></p> <p>Danish: VVS NO 38 1882.120</p>

## 97822677 TP 40-120/2 B 50 Hz

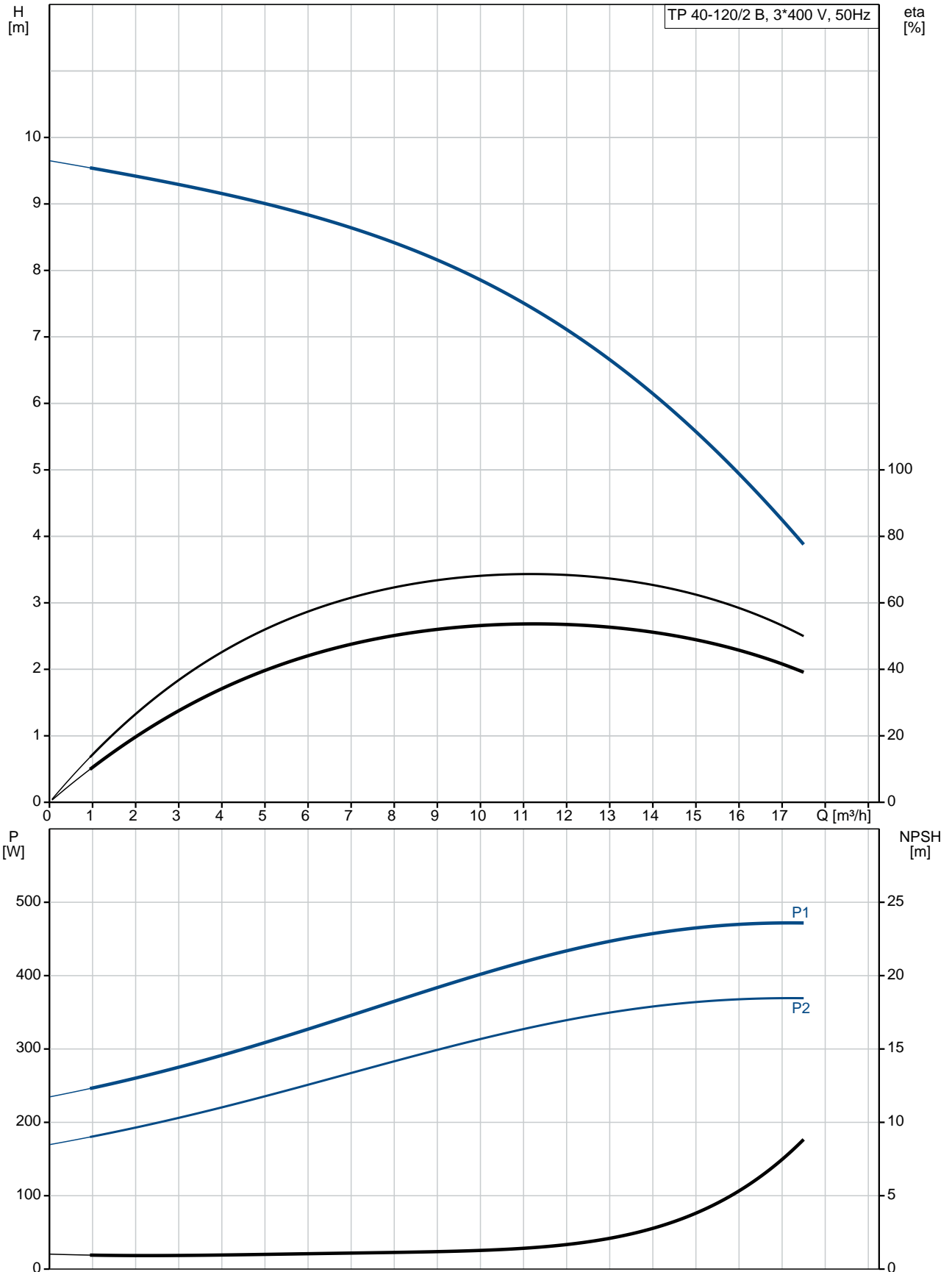

Description	Value
-------------	-------

**General information:**

Product name:	TP 40-120/2 B A-F-Z-BQQE
Product No:	<a href="#">97822677</a>
EAN number:	5710625203650

**Technical:**

Speed for pump data:	2850 rpm
Rated flow:	11.4 m³/h
Rated head:	7.4 m
Head max:	120 dm
Primary shaft seal:	BQQE
Curve tolerance:	ISO9906:2012 3B
Pump version:	A
Model:	A

**Materials:**

Pump housing:	Bronze
	DIN W.-Nr. 2.1050
	ASTM B505-C90700
Impeller:	Stainless steel
	DIN W.-Nr. 1.4301
	AISI 304
Material code:	Z

**Installation:**

Range of ambient temperature:	-30 .. 40 °C
Maximum operating pressure:	10 bar
Flange standard:	DIN
Connect code:	F
Pipe connection:	DN 40
Pressure stage:	PN 6/10
Port-to-port length:	250 mm
Flange size for motor:	FT85

**Liquid:**

Pumped liquid:	Water
Liquid temperature range:	-25 .. 120 °C
Liquid temperature during operation:	20 °C
Density:	998.2 kg/m³

**Electrical data:**

Motor type:	71A
IE Efficiency class:	IE3
Rated power - P2:	0.37 kW
Power (P2) required by pump:	0.37 kW
Mains frequency:	50 Hz
Rated voltage:	3 x 220-240D/380-415Y V
Rated current:	1,74/1,00 A
Starting current:	490-530 %
Cos phi - power factor:	0,80-0,70
Rated speed:	2850-2880 rpm
Efficiency:	IE3 73,8%
Motor efficiency at full load:	73.8 %
Motor efficiency at 3/4 load:	79.0 %
Motor efficiency at 1/2 load:	75.5 %
Number of poles:	2
Enclosure class (IEC 34-5):	55 Dust/Jetting
Insulation class (IEC 85):	F
Motor protec:	NONE

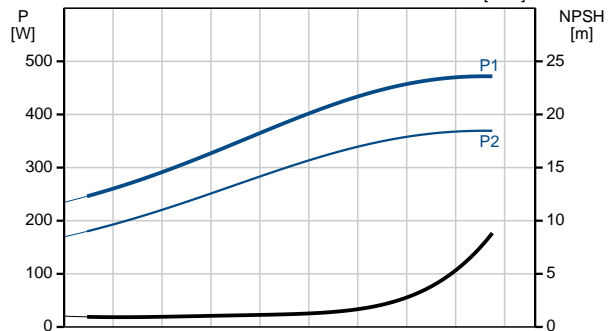
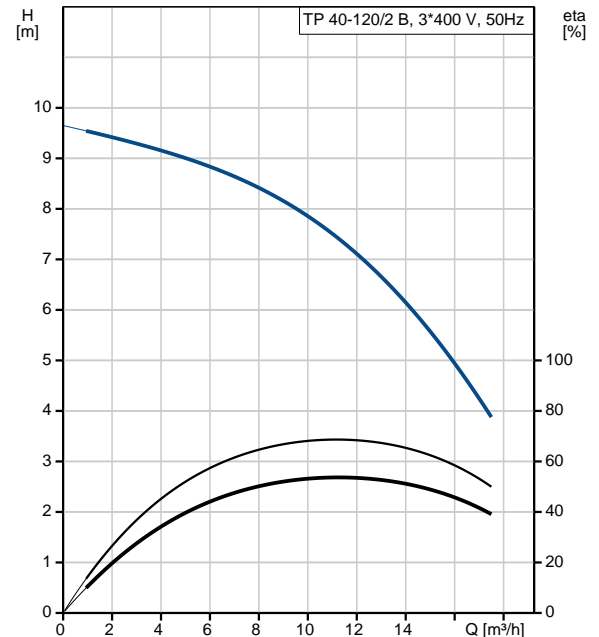



Company name:

Created by:

Phone:

Date:

30/06/2017

Description	Value
Motor No:	85805102
<b>Others:</b>	
Minimum efficiency index, MEI :	0.70
ErP status:	EuP Standalone/Prod.
Net weight:	24.2 kg
Gross weight:	27.7 kg
Shipping volume:	0.06 m <sup>3</sup>
Danish:	VVS NO 38 1882.120

## 97822677 TP 40-120/2 B 50 Hz

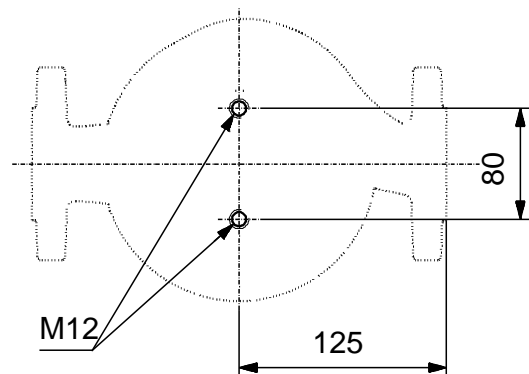
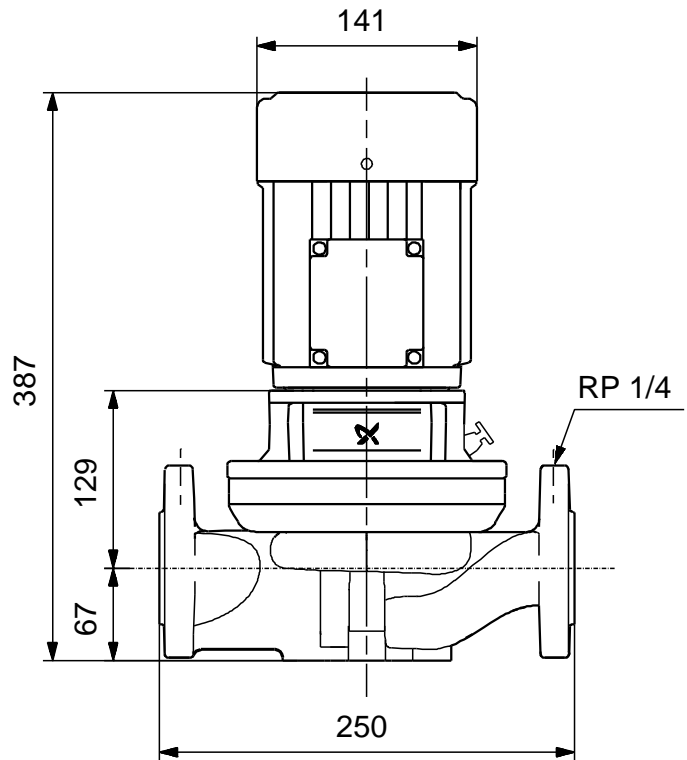
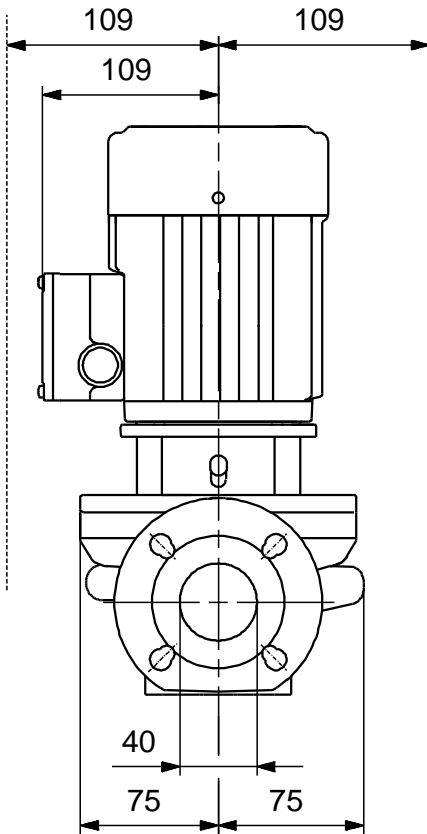

Note! All units are in [mm] unless others are stated.  
Disclaimer: This simplified dimensional drawing does not show all details.

**97822677 TP 40-120/2 B 50 Hz**



Note! All units are in [mm] unless others are stated.