

Qty.	Description
------	-------------

1	TPED 65-660/2-S A-F-A-BQQE
---	----------------------------



Product No.: [96945781](#)

Single-stage, close-coupled, volute pump with in-line suction and discharge ports of identical diameter. The pump is of the top-pull-out design, i.e. the power head (motor, pump head and impeller) can be removed for maintenance or service while the pump housing remains in the pipework.

TPED 65-660/2-S A-F-A-BQQE The pump is fitted with an unbalanced rubber bellows seal. TPED 65-660/2-S A-F-A-BQQE The shaft seal is according to EN 12756. Pipework connection is via PN 16 DIN flanges (EN 1092-2 and ISO 7005-2).

Pipework connection is via PN 16 DIN flanges (EN 1092-2 and ISO 7005-2).

The pump is fitted with a fan-cooled asynchronous motor.

The motor includes a frequency converter and PI controller in the motor terminal box. This enables continuously variable control of the motor speed, which again enables adaptation of the performance to a given requirement.

The pump is fitted with a differential-pressure sensor.

Further product details

The pump is suitable for applications requiring pressure control. The pump is fitted with a differential-pressure transmitter registering the differential pressure across the pump and enabling constant pressure or proportional-pressure control of the pump.

A control panel enables setting of required setpoint as well as setting of pump to "Min." or "Max." operation or to "Stop". The control panel has indicator lights for "Operation" and "Fault".

Communication with the pump is possible by means of the Grundfos GO Remote (accessory). The remote control enables further settings as well as reading out of a number of parameters such as "Actual value", "Speed", "Power input" and total "Power consumption".

Pump

Pump housing and pump head are electrocoated to improve the corrosion resistance.

Electrocoating includes:

- 1) Alkaline-based cleaning.
- 2) Pretreatment with zinc phosphate coating.
- 3) Cathodic electrocoating (epoxy).
- 4) Curing of paint film at 200-250 °C.

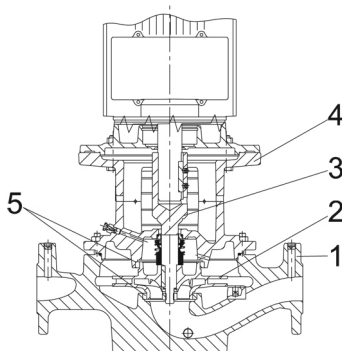

1: Pump housing

2: Impeller

Qty.	Description
	<p>3: Stub shaft 4: Pump head/motor stool 5: Wear rings</p> <p>The pump housing is provided with a replaceable brass neck ring to reduce the amount of liquid running from the outlet side of the impeller to the inlet side. The impeller is secured to the shaft with a nut.</p> <p>The pump is fitted with an unbalanced rubber bellows seal with torque transmission across the spring and around the bellows. Due to the bellows, the seal does not wear the shaft, and the axial movement is not prevented by deposits on the shaft.</p> <p>Primary seal:</p> <ul style="list-style-type: none"> • Rotating seal ring material: silicon carbide (SiC) • Stationary seat material: silicon carbide (SiC) <p>This material pairing is used where higher corrosion resistance is required. The high hardness of this material pairing offers good resistance against abrasive particles.</p> <p>Secondary seal material: EPDM (ethylene-propylene rubber) EPDM has excellent resistance to hot water. EPDM is not suitable for mineral oils.</p> <p>A circulation of liquid through the duct of the air vent screw ensures lubrication and cooling of the shaft seal. The flanges have tappings for mounting of pressure gauges.</p> <p>The motor stool forms connection between the pump housing and the motor, and is equipped with a manual air vent screw for venting of the pump housing and the shaft seal chamber. The sealing between motor stool and pump housing is an O-ring.</p> <p>The central part of the motor stool is provided with guards for protection against the shaft and coupling. The pump shaft is fastened directly on the motor shaft with key and set screws.</p> <p>Motor</p> <p>The motor is a totally enclosed, fan-cooled motor with principal dimensions to IEC and DIN standards. Electrical tolerances comply with IEC 60034.</p> <p>The motor is flange-mounted with free-hole flange (FF). Motor-mounting designation in accordance with IEC 60034-7: IM B 5, IM V 1 (Code I) / IM 3001, IM 3011 (Code II).</p> <p>The motor efficiency is classified as IE3 in accordance with IEC 60034-30-1. The motor requires no external motor protection. The motor control unit incorporates protection against slow- and quick-rising temperatures, e.g. constant overload and stalled conditions.</p> <p>TPED 65-660/2-S A-F-A-BQQE The terminal box holds terminals for these connections:</p> <ul style="list-style-type: none"> - pump start/stop input (potential-free contact) - remote setpoint setting via analog signal, 0-10 V, 0(4)-20 mA - 10 V voltage supply for setpoint potentiometer, I_{max} = 5 mA - one analog sensor input, 0-10 V, 0(4)-20 mA; the factory-fitted pressure sensor is connected to this input - 24 V voltage supply for sensor, I_{max} = 40 mA - one digital input - two potential-free fault signal relays with changeover contact, reporting "Fault", "Operation" or "Ready" - RS-485 GENIbus connection - interface for Grundfos CIM fieldbus module. <p>TPED 65-660/2-S A-F-A-BQQE The terminal box holds terminals for these connections:</p> <ul style="list-style-type: none"> - pump start/stop input (potential-free contact) - remote setpoint setting via analog signal, 0-10 V, 0(4)-20 mA - 10 V voltage supply for setpoint potentiometer, I_{max} = 5 mA - one analog sensor input, 0-10 V, 0(4)-20 mA; the factory-fitted pressure sensor is connected to this input - 24 V voltage supply for sensor, I_{max} = 40 mA - one digital input - two potential-free fault signal relays with changeover contact, reporting "Fault", "Operation" or "Ready" - cable for communication between the two power heads

Qty. Description

- selector switch for alternating operation and standby operation
- RS-485 GENIbus connection
- interface for Grundfos CIU fieldbus module.

Technical data

Controls:

Frequency converter: Built-in

Liquid:

Pumped liquid: Water
 Liquid temperature range: -25 .. 120 °C
 Selected liquid temperature: 20 °C
 Density at selected liquid temperature: 998.2 kg/m³

Technical:

Pump speed on which pump data are based: 2940 rpm
 Rated flow: 68.2 m³/h
 Rated head: 55.6 m
 Actual impeller diameter: 219 mm
 Primary shaft seal: BQQE
 Curve tolerance: ISO9906:2012 3B

Materials:

Pump housing: Cast iron
 EN-JL1040
 ASTM A48-40 B
 Impeller: Cast iron
 EN-JL1030
 ASTM A48-30 B

Installation:

Range of ambient temperature: -20 .. 40 °C
 Maximum operating pressure: 16 bar
 Max pressure at stated temp: 16 bar / 120 °C
 Flange standard: DIN
 Pipe connection: DN 65
 Pressure rating: PN 16
 Port-to-port length: 475 mm
 Flange size for motor: FF300

Electrical data:

Motor type: 160LB
 IE Efficiency class: IE3
 Rated power - P2: 18.5 kW
 Mains frequency: 50 Hz
 Rated voltage: 3 x 380-480 V
 Rated current: 37.0-31.0 A
 Cos phi - power factor: 0.91-0.88
 Rated speed: 480-3540 rpm
 Efficiency: IE3 92,4%
 Motor efficiency at full load: 92.4 %
 Number of poles: 2
 Enclosure class (IEC 34-5): IP55
 Insulation class (IEC 85): F
 Motor No: 85901238

Others:

Minimum efficiency index, MEI : 0.53



Company name:

Created by:

Phone:

Date:

29/08/2019

Qty.	Description
------	-------------

	ErP status: EuP Standalone/Prod.
	Net weight: 432 kg
	Gross weight: 515 kg
	Shipping volume: 1.53 m ³

96945781 TPED 65-660/2-S A-F-A-BQQE 50 Hz

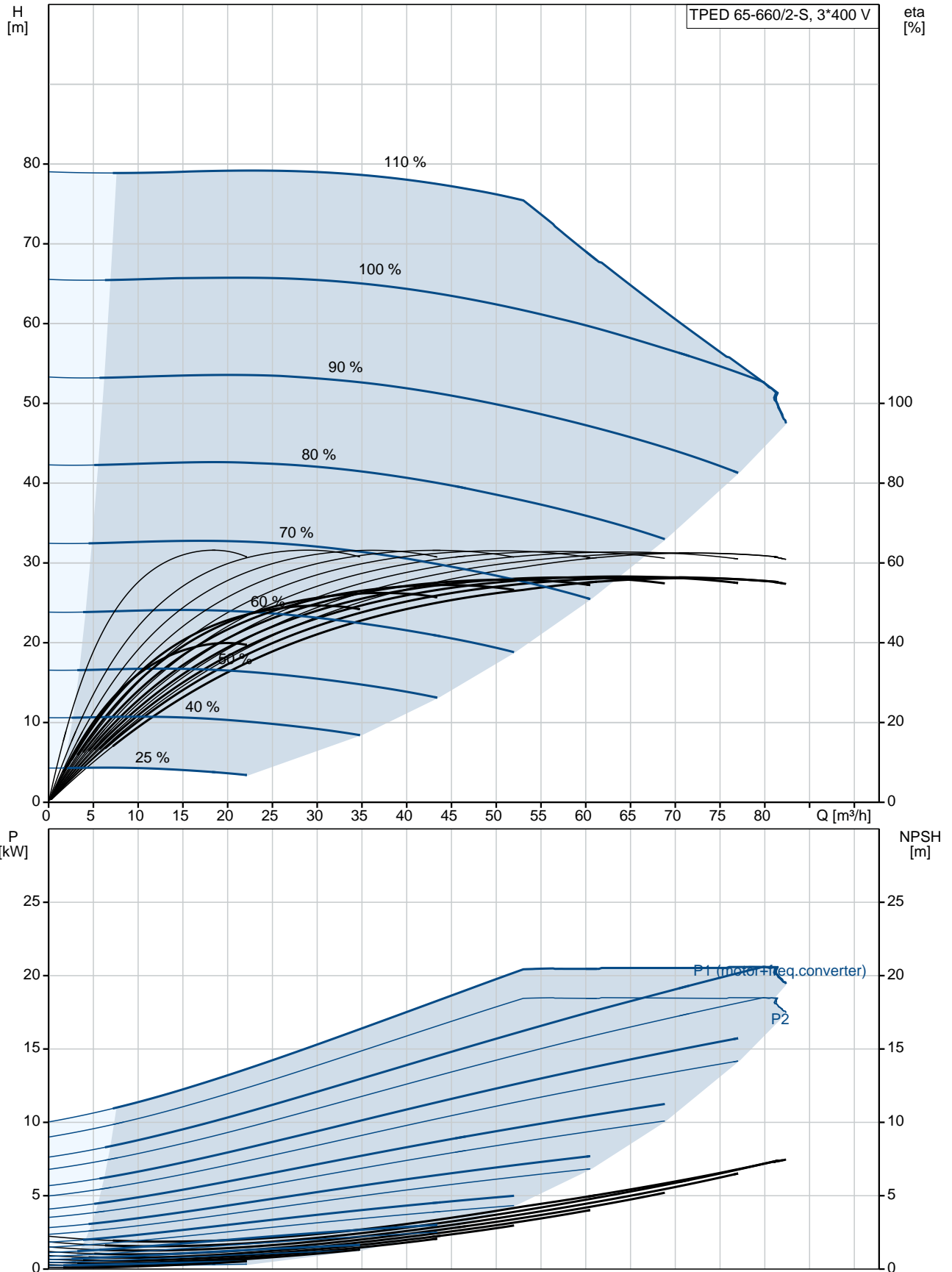

Description	Value
General information:	
Product name:	TPED 65-660/2-S A-F-A-BQQE
Product No:	96945781
EAN number:	5700314376826 5700314376826
Technical:	
Pump speed on which pump data are based:	2940 rpm
Rated flow:	68.2 m ³ /h
Rated head:	55.6 m
Head max:	660 dm
Actual impeller diameter:	219 mm
Primary shaft seal:	BQQE
Curve tolerance:	ISO9906:2012 3B
Pump version:	A
Model:	A
Materials:	
Pump housing:	Cast iron EN-JL1040 ASTM A48-40 B
Impeller:	Cast iron EN-JL1030 ASTM A48-30 B
Material code:	A
Installation:	
Range of ambient temperature:	-20 .. 40 °C
Maximum operating pressure:	16 bar
Max pressure at stated temp:	16 bar / 120 °C
Flange standard:	DIN
Pipe connection:	DN 65
Pressure rating:	PN 16
Port-to-port length:	475 mm
Flange size for motor:	FF300
Connect code:	F
Liquid:	
Pumped liquid:	Water
Liquid temperature range:	-25 .. 120 °C
Selected liquid temperature:	20 °C
Density at selected liquid temperature:	998.2 kg/m ³
Electrical data:	
Motor type:	160LB
IE Efficiency class:	IE3
Rated power - P2:	18.5 kW
Mains frequency:	50 Hz
Rated voltage:	3 x 380-480 V
Rated current:	37.0-31.0 A
Cos phi - power factor:	0.91-0.88
Rated speed:	480-3540 rpm
Efficiency:	IE3 92,4%
Motor efficiency at full load:	92.4 %
Number of poles:	2
Enclosure class (IEC 34-5):	IP55
Insulation class (IEC 85):	F
Motor protec:	YES
Motor No:	85901238
Controls:	
Control panel:	BS
Function Module:	TPED

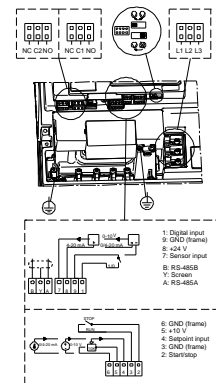
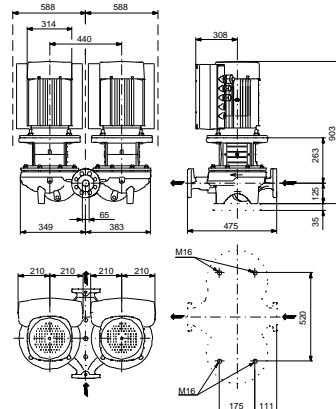
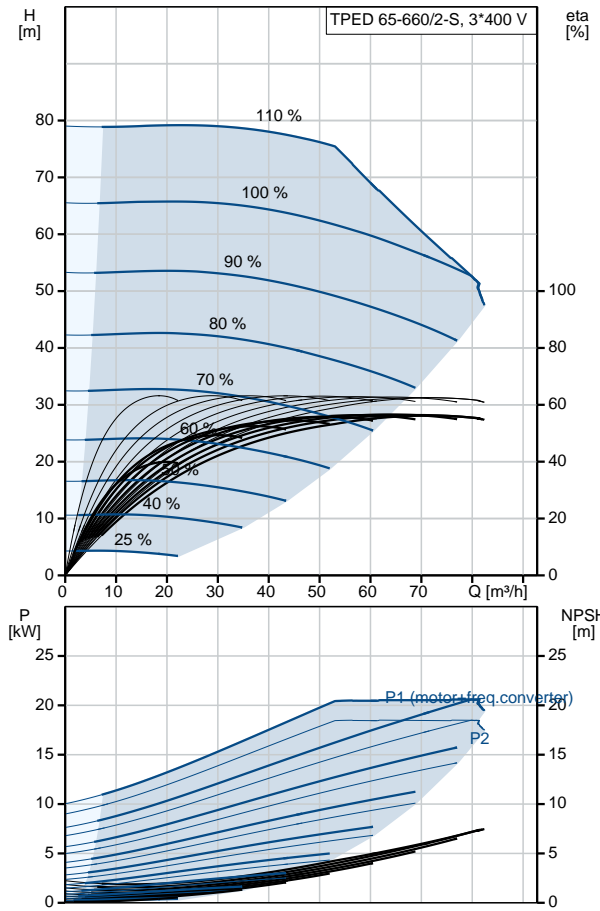



Company name:

Created by:

Phone:

Date:

29/08/2019

Description	Value
Frequency converter:	Built-in
Others:	
Minimum efficiency index, MEI :	0.53
ErP status:	EuP Standalone/Prod.
Net weight:	432 kg
Gross weight:	515 kg
Shipping volume:	1.53 m ³
Config. file no:	95139459

96945781 TPED 65-660/2-S A-F-A-BQQE 50 Hz

