

**Qty. Description**

1 GT-U-1500 PN16 DN65 V (coated flange)



Product No.: [96603429](#)

Grundfos GT-U-1500 PN16 DN65 V (coated flange) is a Bladder pressure tank, with a capacity of 1500.0 l and Vertical installation. The tanks are approved for drinking water. The GT-U-1500 PN16 DN65 V (coated flange) is designed for a maximum operation pressure of 16 bar and a maximum liquid temperature of 70 °C.

The tank is a steel pressure tank with a replaceable, non-toxic butyl rubber bladder enclosed by compressed nitrogen.

The diaphragm is a chlorine-resistant 100 % butyl diaphragm with a precision-moulded copolymer polypropylene liner for superior air and water separation.

The tank has a FlowThru connection, which constantly flushes the tank while the pump is running.

This ensures that the water in the tank remains fresh and eliminates the risk of stagnant water during normal system operation.

The diaphragm is a chlorine-resistant 100 % butyl diaphragm with a precision-moulded copolymer polypropylene liner for superior air and water separation.

The tank has a FlowThru connection, which constantly flushes the tank while the pump is running.

This ensures that the water in the tank remains fresh and eliminates the risk of stagnant water during normal system operation.

The tanks have a non-replaceable diaphragm that is pre-charged with nitrogen (1.5 bar).

The tanks have a non-toxic butyl rubber diaphragm, dividing the tank chamber into two compartments.

The upper compartment contains compressed nitrogen.

The lower compartment has a liner of polypropylene (PP) and is filled with water from the pump.

A pressure tank ensures controlled pressure in the water supply and thereby limits the switching frequency of the pump in case of low water consumption or leakage loss.

The result is increased comfort in your installation by limiting the start/stop frequency of your pump, and it increases system comfort by compensating for pressure drops when a tap is opened, while reducing problems with water hammer in the pipework.

**Liquid:**

Maximum liquid temperature: 70 °C

**Technical:**

Membrane type: Bladder

Maximum used volume: 1200 l

**Materials:**

Basic: Carbon steel

**Installation:**

Maximum operating pressure: 16 bar



Company name:

Created by:

Phone:

Date:

01/10/2021

Qty.	Description
------	-------------

Type of connection:	DIN
Size of connection:	DN 65
Size:	1500.0
Others:	
Net weight:	685 kg
Gross weight:	697 kg
Applicat. typ:	Standard
Country of origin:	PL
Custom tariff no.:	85030099

Description	Value
<b>General information:</b>	
Product name:	GT-U-1500 PN16 DN65 V (coated flange)
Product No:	96603429
EAN number:	5700832103911
<b>Technical:</b>	
Membrane type:	Bladder
Maximum used volume:	1200 l
<b>Materials:</b>	
Basic:	Carbon steel
<b>Installation:</b>	
Maximum operating pressure:	16 bar
Pre-pressure:	4 bar
Type of connection:	DIN
Size of connection:	DN 65
Installation:	Vertical
Size:	1500.0
<b>Liquid:</b>	
Maximum liquid temperature:	70 °C
<b>Others:</b>	
Net weight:	685 kg
Gross weight:	697 kg
Applicat. typ:	Standard
Country of origin:	PL
Custom tariff no.:	85030099

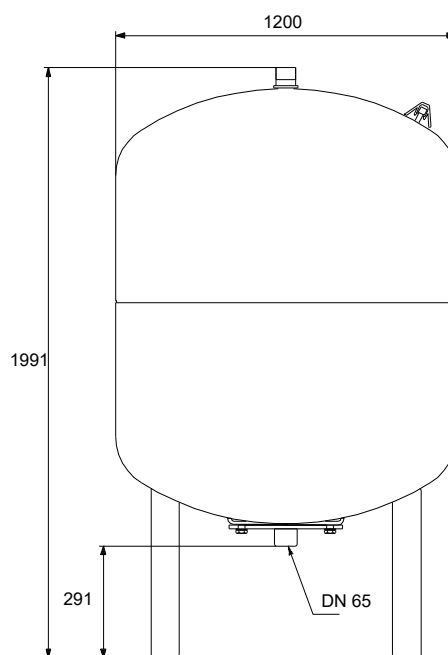

**96603429 GT-U-1500 PN16 DN65 V (coated flange)**

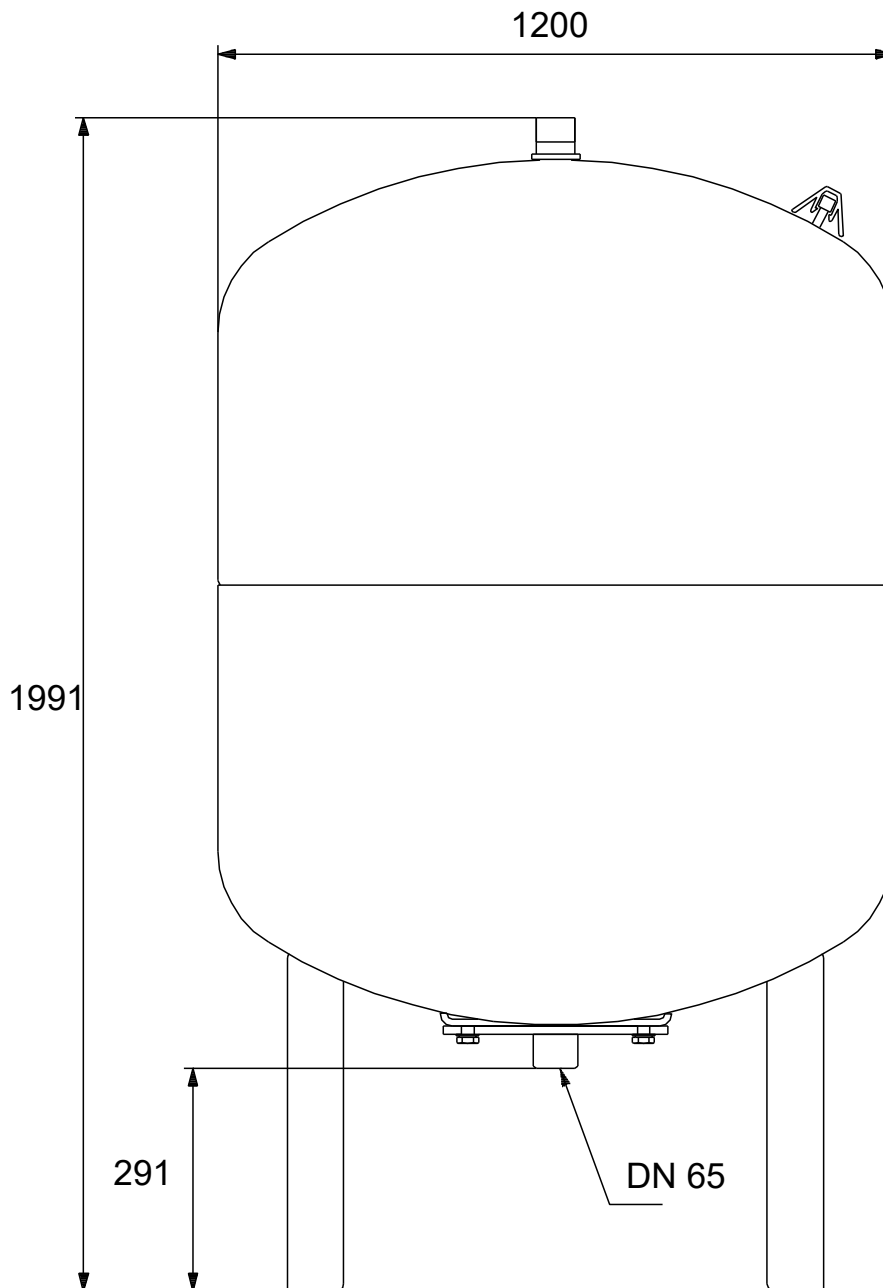

Note! All units are in [mm] unless others are stated.  
Disclaimer: This simplified dimensional drawing does not show all details.