

Qty.	Description
1	<p data-bbox="201 338 443 365"><b>GT-HR-100 PN6 R1 V</b></p> <div data-bbox="320 416 459 613" style="text-align: center;">  </div> <p data-bbox="201 658 464 685">Product No.: <a href="#">96573397</a></p> <p data-bbox="201 719 1453 792">Grundfos GT-HR-100 PN6 R1 V is a diaphragm pressure tank, with a capacity of 100.0 l and Vertical installation. The tanks are approved for drinking water. The GT-HR-100 PN6 R1 V is designed for a maximum operation pressure of 6 bar and a maximum liquid temperature of 90 °C.</p> <p data-bbox="201 954 1453 1003">The diaphragm is a chlorine-resistant 100 % butyl diaphragm with a precision-moulded copolymer polypropylene liner for superior air and water separation.</p> <p data-bbox="201 1010 1246 1037">The tank has a FlowThru connection, which constantly flushes the tank while the pump is running.</p> <p data-bbox="201 1043 1442 1093">This ensures that the water in the tank remains fresh and eliminates the risk of stagnant water during normal system operation.</p> <p data-bbox="201 1160 1453 1209">The diaphragm is a chlorine-resistant 100 % butyl diaphragm with a precision-moulded copolymer polypropylene liner for superior air and water separation.</p> <p data-bbox="201 1216 1246 1243">The tank has a FlowThru connection, which constantly flushes the tank while the pump is running.</p> <p data-bbox="201 1249 1442 1299">This ensures that the water in the tank remains fresh and eliminates the risk of stagnant water during normal system operation.</p> <p data-bbox="201 1335 1262 1361">The tank is a steel pressure tank with a non-replaceable rubber diaphragm for heating applications.</p> <p data-bbox="201 1368 1150 1395">The tanks have a non-replaceable diaphragm that is pre-charged with nitrogen (1.5 bar).</p> <p data-bbox="201 1402 1289 1429">The tanks have a non-toxic butyl rubber diaphragm, dividing the tank chamber into two compartments.</p> <p data-bbox="201 1435 799 1462">The upper compartment contains compressed nitrogen.</p> <p data-bbox="201 1469 1225 1496">The lower compartment has a liner of polypropylene (PP) and is filled with water from the pump.</p> <p data-bbox="201 1514 1406 1563">A pressure tank ensures controlled pressure in the water supply and thereby limits the switching frequency of the pump in case of low water consumption or leakage loss.</p> <p data-bbox="201 1570 1437 1644">The result is increased comfort in your installation by limiting the start/stop frequency of your pump, and it increases system comfort by compensating for pressure drops when a tap is opened, while reducing problems with water hammer in the pipework.</p> <p data-bbox="201 1715 628 1771">Liquid: Liquid max temp: 90 °C</p> <p data-bbox="201 1805 683 1861">Technical: Membrane type: diaphragm</p> <p data-bbox="201 1895 703 1951">Materials: Basic: Carbon steel</p> <p data-bbox="201 1984 632 2096">Installation: Maximum operating pressure: 6 bar Type of connection: R Size of connection: 1 inch</p>



Company name:

Created by:

Phone:

Date:

12/10/2021

Qty.	Description
------	-------------

	Size: 100.0
	Others:
	Net weight: 15.8 kg
	Gross weight: 17.6 kg
	Applicat. typ: Heating standard
	Finnish LVI No.: 3413416
	Norwegian NRF no.: 8402719

Description	Value
<b>General information:</b>	
Product name:	GT-HR-100 PN6 R1 V
Product No:	<a href="#">96573397</a>
EAN number:	5700830555101
Price:	
<b>Technical:</b>	
Membrane type:	diaphragm
<b>Materials:</b>	
Basic:	Carbon steel
<b>Installation:</b>	
Maximum operating pressure:	6 bar
Pre-pressure:	1.5 bar
Type of connection:	R
Size of connection:	1 inch
Installation:	Vertical
Size:	100.0
<b>Liquid:</b>	
Liquid max temp:	90 °C
<b>Others:</b>	
Net weight:	15.8 kg
Gross weight:	17.6 kg
Applicat. typ:	Heating standard
Finnish LVI No.:	3413416
Norwegian NRF no.:	8402719

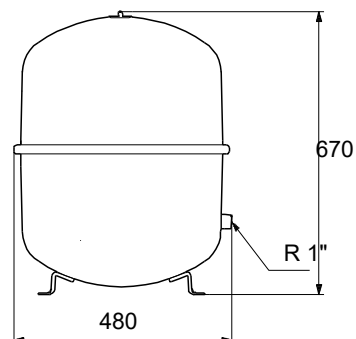

**96573397 GT-HR-100 PN6 R1 V**

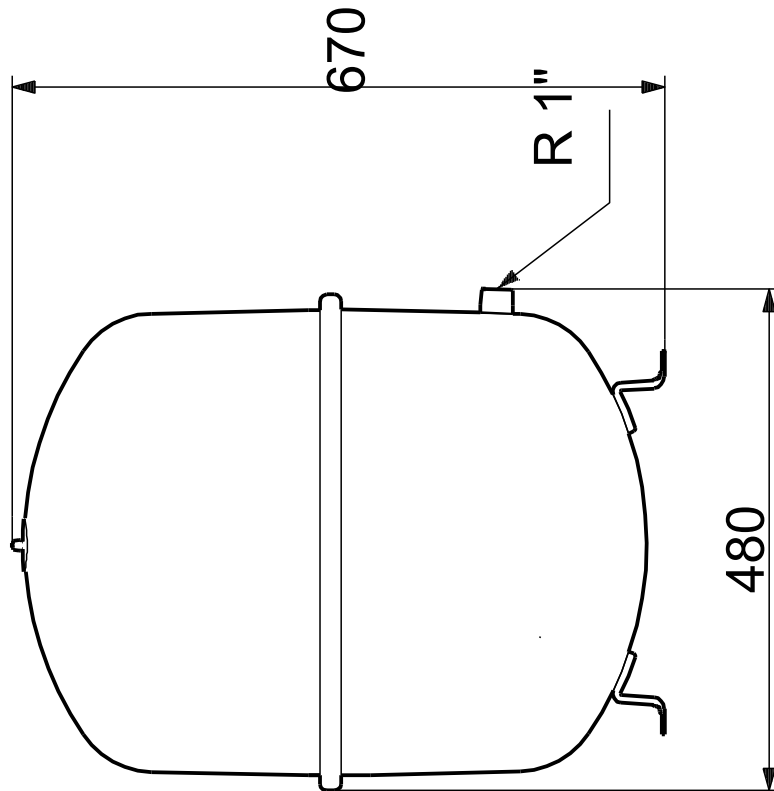

Note! All units are in [mm] unless others are stated.  
Disclaimer: This simplified dimensional drawing does not show all details.