

Qty. Description

1 CRN 1-33 A-FGJ-H-E-HQQE



Note! Product picture may differ from actual product

Product No.: [96533106](#)

Vertical, multistage centrifugal pump with inlet and outlet ports on same the level (inline). Pump materials in contact with the liquid are in high-grade stainless steel. A cartridge shaft seal ensures high reliability, safe handling, and easy access and service. Power transmission is via a rigid split coupling. Pipe connection is via combined DIN-ANSI-JIS flanges.

The pump is fitted with a 1-phase, fan-cooled asynchronous motor.

Controls:

Frequency converter: NONE

Liquid:

Pumped liquid: Water
 Liquid temperature range: -20 .. 120 °C
 Liquid temperature during operation: 20 °C
 Density: 998.2 kg/m³

Technical:

Pump speed on which pump data are based: 2730 rpm
 Rated flow: 1.8 m³/h
 Rated head: 144.6 m
 Pump orientation: Vertical
 Shaft seal arrangement: Single
 Code for shaft seal: HQQE
 Approvals on nameplate: CE, EAC, ACS
 Curve tolerance: ISO9906:2012 3B

Materials:

Base: Stainless steel
 EN 1.4408
 AISI 316
 Impeller: Stainless steel
 EN 1.4401
 AISI 316
 Bearing: SIC

Installation:

Maximum ambient temperature: 40 °C
 Maximum operating pressure: 25 bar

Qty.	Description
	<p>Max pressure at stated temp: 25 bar / 120 °C 25 bar / -20 °C</p> <p>Type of connection: DIN / ANSI / JIS</p> <p>Size of inlet connection: DN 25/32 1 1/4 inch</p> <p>Size of outlet connection: DN 25/32 1 1/4 inch</p> <p>Pressure rating for pipe connection: PN 25</p> <p>Flange rating inlet: 300 lb</p> <p>Flange size for motor: FT115</p> <p>Electrical data:</p> <p>Motor standard: IEC</p> <p>Motor type: 90LC</p> <p>Rated power - P2: 2.2 kW</p> <p>Power (P2) required by pump: 2.2 kW</p> <p>Mains frequency: 50 Hz</p> <p>Rated voltage: 1 x 220-230/240 V</p> <p>Rated current: 14,0-13,6/12,6 A</p> <p>Starting current: 330 %</p> <p>Cos phi - power factor: 1.00</p> <p>Rated speed: 2730/2720 rpm</p> <p>Motor efficiency at full load: 75 %</p> <p>Number of poles: 2</p> <p>Enclosure class (IEC 34-5): 55 Dust/Jetting</p> <p>Insulation class (IEC 85): F</p> <p>Others:</p> <p>Minimum efficiency index, MEI η_{min}: 0.70</p> <p>Net weight: 49 kg</p> <p>Gross weight: 53.7 kg</p> <p>Shipping volume: 0.148 m³</p>

96533106 CRN 1-33 A-FGJ-H-E-HQQE 50 Hz

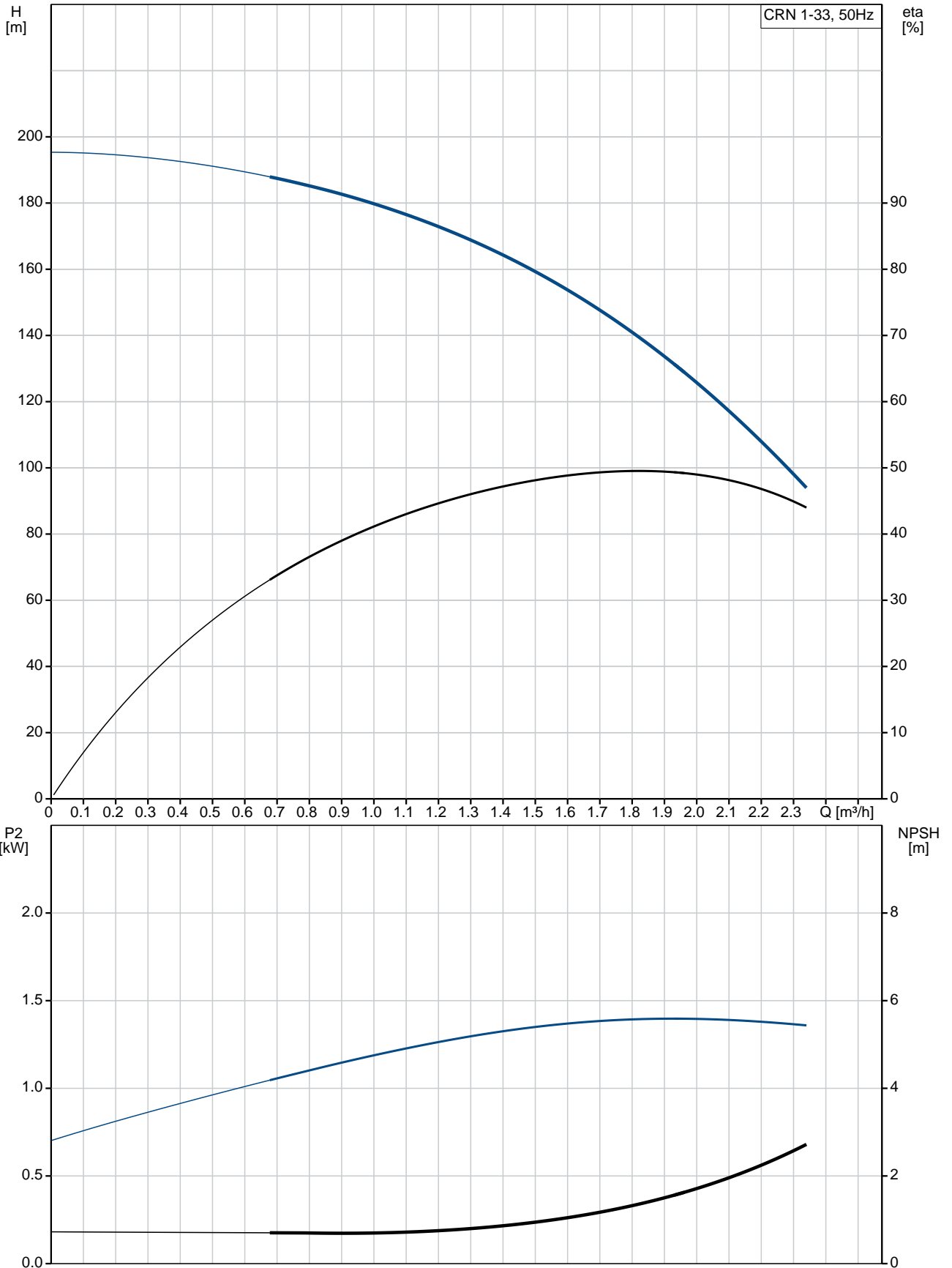

Description	Value
General information:	
Product name:	CRN 1-33 A-FGJ-H-E-HQQE
Product No:	96533106
EAN number:	5700397424469
Technical:	
Pump speed on which pump data are based:	2730 rpm
Rated flow:	1.8 m ³ /h
Rated head:	144.6 m
Head max:	199.8 m
Stages:	33
Impellers:	33
Number of reduced-diameter impellers:	0
Low NPSH:	N
Pump orientation:	Vertical
Shaft seal arrangement:	Single
Code for shaft seal:	HQQE
Approvals on nameplate:	CE, EAC, ACS
Curve tolerance:	ISO9906:2012 3B
Pump version:	A
Model:	A
Materials:	
Base:	Stainless steel EN 1.4408 AISI 316
Impeller:	Stainless steel EN 1.4401 AISI 316
Material code:	H
Code for rubber:	E
Bearing:	SIC
Installation:	
Maximum ambient temperature:	40 °C
Maximum operating pressure:	25 bar
Max pressure at stated temp:	25 bar / 120 °C 25 bar / -20 °C
Type of connection:	DIN / ANSI / JIS
Size of inlet connection:	DN 25/32 1 1/4 inch
Size of outlet connection:	DN 25/32 1 1/4 inch
Pressure rating for pipe connection:	PN 25
Flange rating inlet:	300 lb
Flange size for motor:	FT115
Connect code:	FGJ
Liquid:	
Pumped liquid:	Water
Liquid temperature range:	-20 .. 120 °C
Liquid temperature during operation:	20 °C
Density:	998.2 kg/m ³
Electrical data:	
Motor standard:	IEC
Motor type:	90LC
Rated power - P2:	2.2 kW
Power (P2) required by pump:	2.2 kW
Mains frequency:	50 Hz
Rated voltage:	1 x 220-230/240 V
Rated current:	14,0-13,6/12,6 A

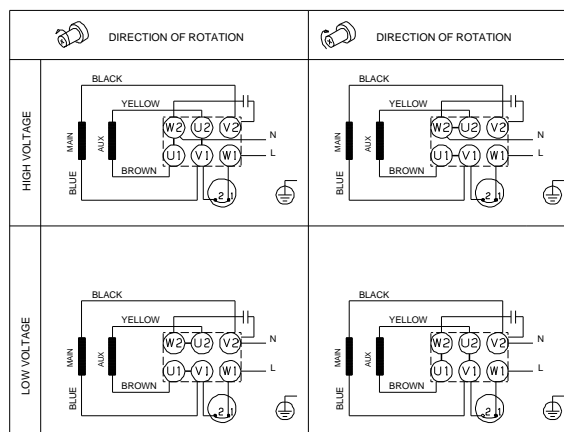
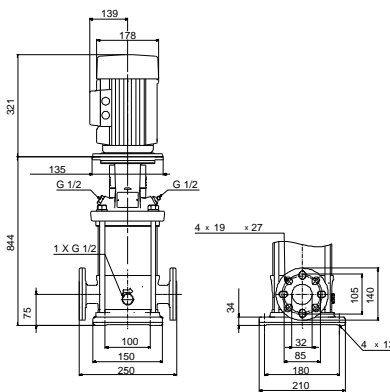
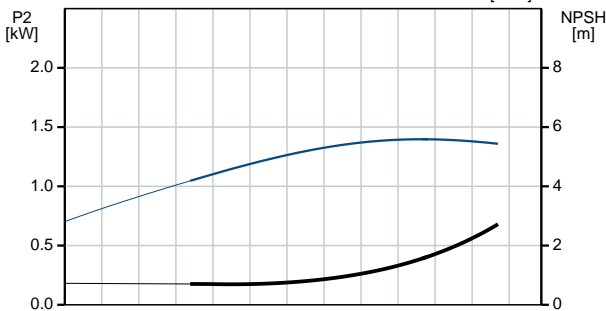
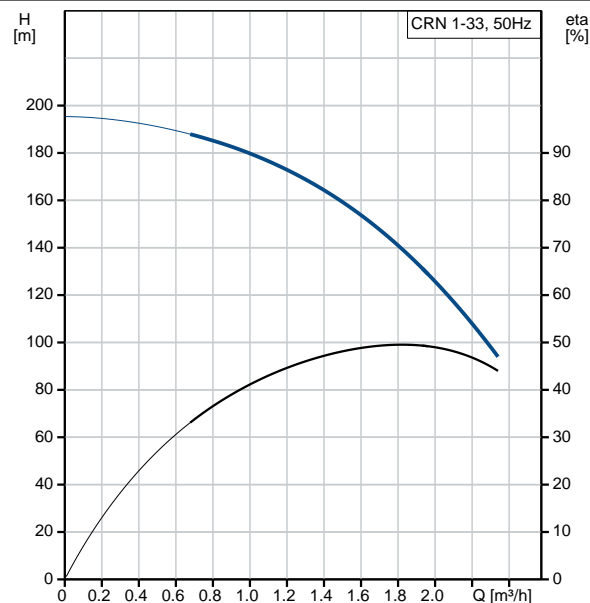



Company name:

Created by:

Phone:

Date:

12/03/2019

Description	Value
Starting current:	330 %
Cos phi - power factor:	1.00
Rated speed:	2730/2720 rpm
Motor efficiency at full load:	75 %
Number of poles:	2
Enclosure class (IEC 34-5):	55 Dust/Jetting
Insulation class (IEC 85):	F
Motor protec:	PTO
Motor No:	85215708
Controls:	
Frequency converter:	NONE
Others:	
Minimum efficiency index, MEI η ‰:	0.70
Net weight:	49 kg
Gross weight:	53.7 kg
Shipping volume:	0.148 m ³
Sales region:	Great Britain