

Qty.	Description
1	<p data-bbox="199 338 512 367"><b>CRN 1S-19 A-P-A-E-HQQE</b></p>  <p data-bbox="199 660 469 689">Product No.: <a href="#">96516056</a></p> <p data-bbox="199 719 1382 797">Vertical, multistage centrifugal pump with inlet and outlet ports on same the level (inline). Pump materials in contact with the liquid are in high-grade stainless steel. Power transmission is via a rigid split coupling. Pipe connection is via PJE (Victaulic®) couplings.</p> <p data-bbox="199 835 935 864">The pump is fitted with a 3-phase, fan-cooled asynchronous motor.</p> <p data-bbox="199 896 316 925"><b>Controls:</b></p> <p data-bbox="199 925 638 954">Frequency converter: NONE</p> <p data-bbox="199 985 288 1014"><b>Liquid:</b></p> <p data-bbox="199 1014 707 1133">Pumped liquid: Water Liquid temperature range: -20 .. 120 °C Liquid temperature during operation: 20 °C Density: 998.2 kg/m<sup>3</sup></p> <p data-bbox="199 1164 328 1193"><b>Technical:</b></p> <p data-bbox="199 1193 820 1429">Pump speed on which pump data are based: 2856 rpm Rated flow: 0.9 m<sup>3</sup>/h Rated head: 73.4 m Pump orientation: Vertical Shaft seal arrangement: Single Code for shaft seal: HQQE Approvals on nameplate: CE, EAC, ACS Curve tolerance: ISO9906:2012 3B</p> <p data-bbox="199 1460 320 1489"><b>Materials:</b></p> <p data-bbox="199 1489 727 1697">Base: Stainless steel EN 1.4408 AISI 316 Impeller: Stainless steel EN 1.4401 AISI 316 Bearing: SIC</p> <p data-bbox="199 1729 344 1758"><b>Installation:</b></p> <p data-bbox="199 1758 740 2085">Maximum ambient temperature: 40 °C Maximum operating pressure: 25 bar Max pressure at stated temp: 25 bar / 120 °C 25 bar / -20 °C Type of connection: PJE Size of inlet connection: DN 32 1 1/4 inch Size of outlet connection: DN 32 1 1/4 inch Pressure rating for pipe connection: PN 50 Flange size for motor: FT85</p>

Qty.	Description
	<p><b>Electrical data:</b></p> <p>Motor standard: IEC</p> <p>Motor type: 71B</p> <p>IE Efficiency class: IE3</p> <p>Rated power - P2: 0.55 kW</p> <p>Power (P2) required by pump: 0.55 kW</p> <p>Mains frequency: 50 Hz</p> <p>Rated voltage: 3 x 220-240D/380-415Y V</p> <p>Rated current: 2.50/1.44 A</p> <p>Starting current: 580-620 %</p> <p>Cos phi - power factor: 0.80-0.70</p> <p>Rated speed: 2830-2850 rpm</p> <p>Efficiency: IE3 77,8%</p> <p>Motor efficiency at full load: 77.8 %</p> <p>Motor efficiency at 3/4 load: 81.5 %</p> <p>Motor efficiency at 1/2 load: 79.5 %</p> <p>Number of poles: 2</p> <p>Enclosure class (IEC 34-5): 55 Dust/Jetting</p> <p>Insulation class (IEC 85): F</p> <p><b>Others:</b></p> <p>Minimum efficiency index, MEI <math>\hat{\alpha}\%_{\alpha}</math>: 0.54</p> <p>Net weight: 22.4 kg</p> <p>Gross weight: 26.4 kg</p> <p>Shipping volume: 0.092 m<sup>3</sup></p> <p>Danish VVS No.: 385910519</p> <p>Country of origin: HU</p> <p>Custom tariff no.: 84137075</p>

## 96516056 CRN 1S-19 A-P-A-E-HQQE 50 Hz

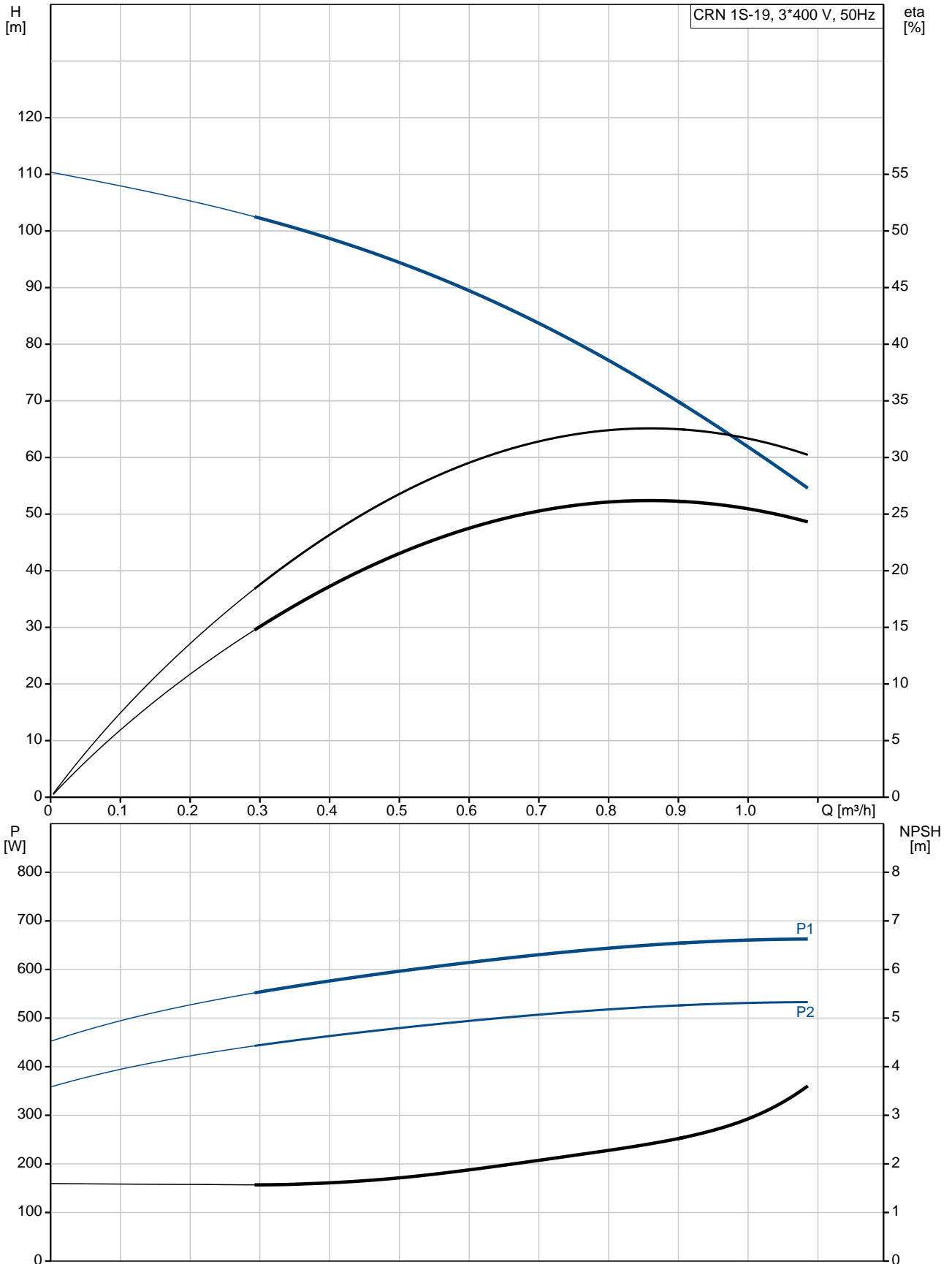

Description	Value
<b>General information:</b>	
Product name:	CRN 1S-19 A-P-A-E-HQQE
Product No:	96516056
EAN number:	5700396736037
Price:	1.153,00 GBP
<b>Technical:</b>	
Pump speed on which pump data are based:	2856 rpm
Rated flow:	0.9 m <sup>3</sup> /h
Rated head:	73.4 m
Head max:	110.1 m
Stages:	19
Impellers:	19
Number of reduced-diameter impellers:	0
Low NPSH:	N
Pump orientation:	Vertical
Shaft seal arrangement:	Single
Code for shaft seal:	HQQE
Approvals on nameplate:	CE, EAC, ACS
Curve tolerance:	ISO9906:2012 3B
Pump version:	A
Model:	A
<b>Materials:</b>	
Base:	Stainless steel EN 1.4408 AISI 316
Impeller:	Stainless steel EN 1.4401 AISI 316
Material code:	A
Code for rubber:	E
Bearing:	SIC
<b>Installation:</b>	
Maximum ambient temperature:	40 °C
Maximum operating pressure:	25 bar
Max pressure at stated temp:	25 bar / 120 °C 25 bar / -20 °C
Type of connection:	PJE
Size of inlet connection:	DN 32 1 1/4 inch
Size of outlet connection:	DN 32 1 1/4 inch
Pressure rating for pipe connection:	PN 50
Flange size for motor:	FT85
Connect code:	P
<b>Liquid:</b>	
Pumped liquid:	Water
Liquid temperature range:	-20 .. 120 °C
Liquid temperature during operation:	20 °C
Density:	998.2 kg/m <sup>3</sup>
<b>Electrical data:</b>	
Motor standard:	IEC
Motor type:	71B
IE Efficiency class:	IE3
Rated power - P2:	0.55 kW
Power (P2) required by pump:	0.55 kW
Mains frequency:	50 Hz

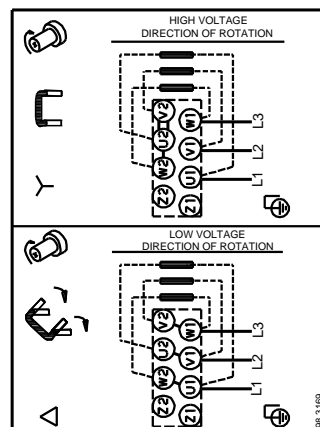
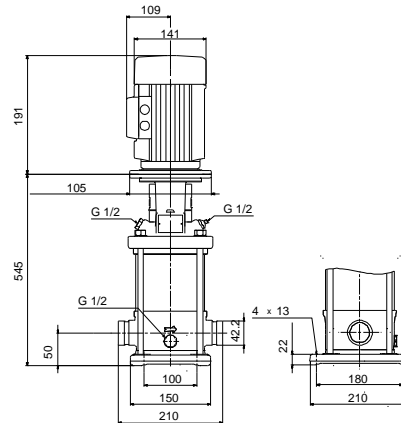
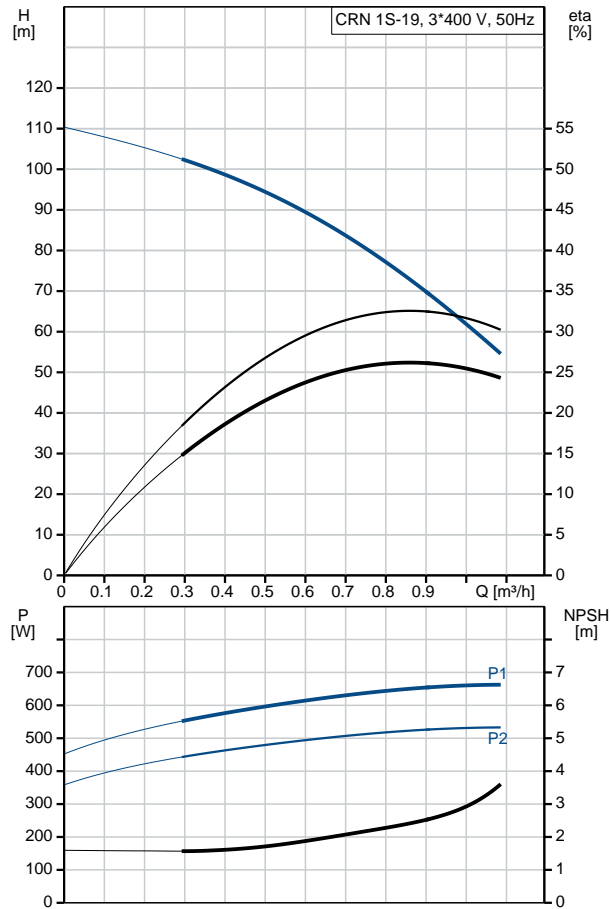



Company name:

Created by:

Phone:

Date:

07/03/2019

Description	Value
Rated voltage:	3 x 220-240D/380-415Y V
Rated current:	2.50/1.44 A
Starting current:	580-620 %
Cos phi - power factor:	0.80-0.70
Rated speed:	2830-2850 rpm
Efficiency:	IE3 77,8%
Motor efficiency at full load:	77.8 %
Motor efficiency at 3/4 load:	81.5 %
Motor efficiency at 1/2 load:	79.5 %
Number of poles:	2
Enclosure class (IEC 34-5):	55 Dust/Jetting
Insulation class (IEC 85):	F
Motor protec:	NONE
Motor No:	85805103
<b>Controls:</b>	
Frequency converter:	NONE
<b>Others:</b>	
Minimum efficiency index, MEI %:	0.54
Net weight:	22.4 kg
Gross weight:	26.4 kg
Shipping volume:	0.092 m <sup>3</sup>
Danish VVS No.:	385910519
Country of origin:	HU
Custom tariff no.:	84137075

## 96516056 CRN 1S-19 A-P-A-E-HQQE 50 Hz

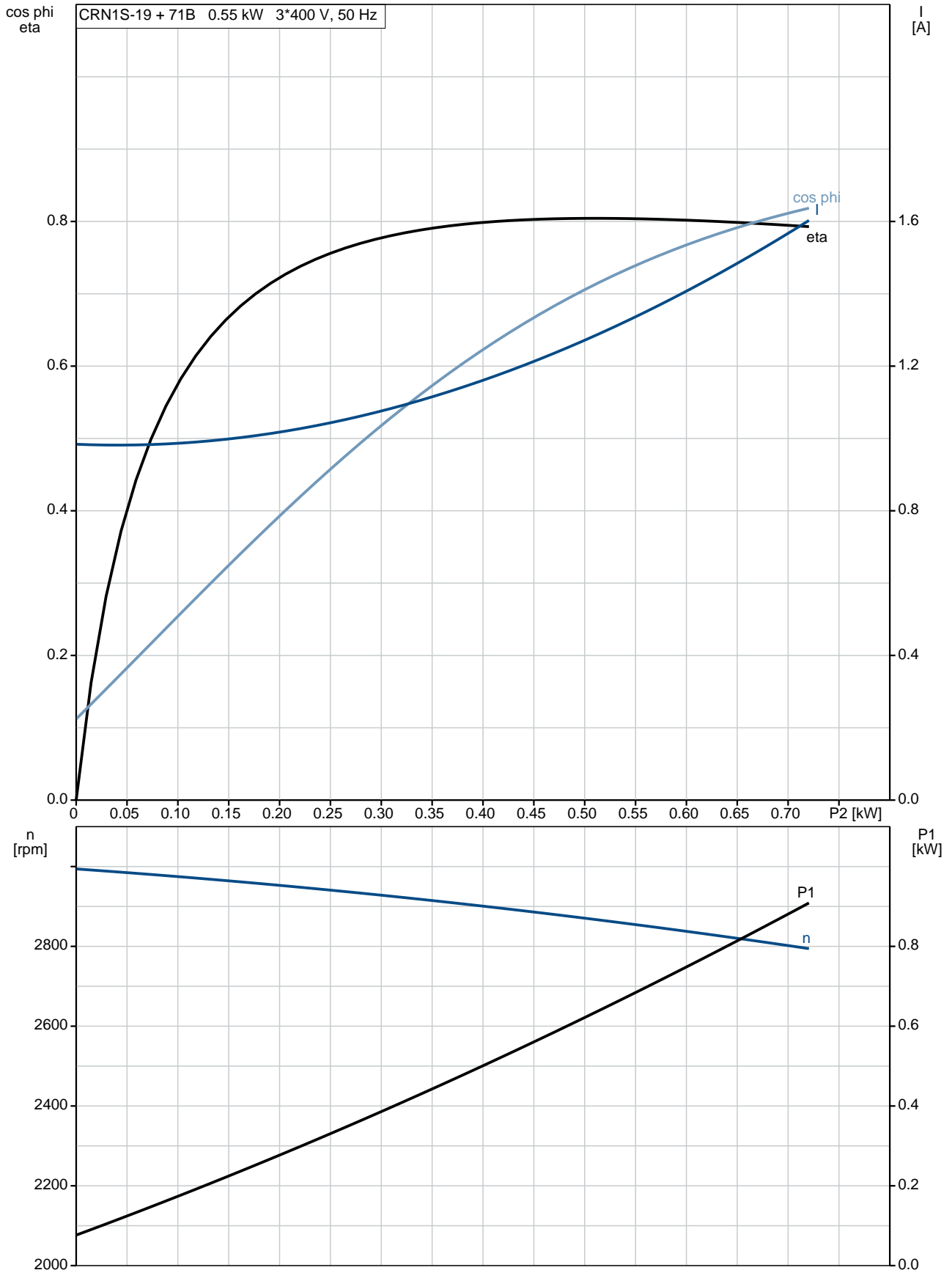

## 96516056 CRN 1S-19 A-P-A-E-HQQE 50 Hz

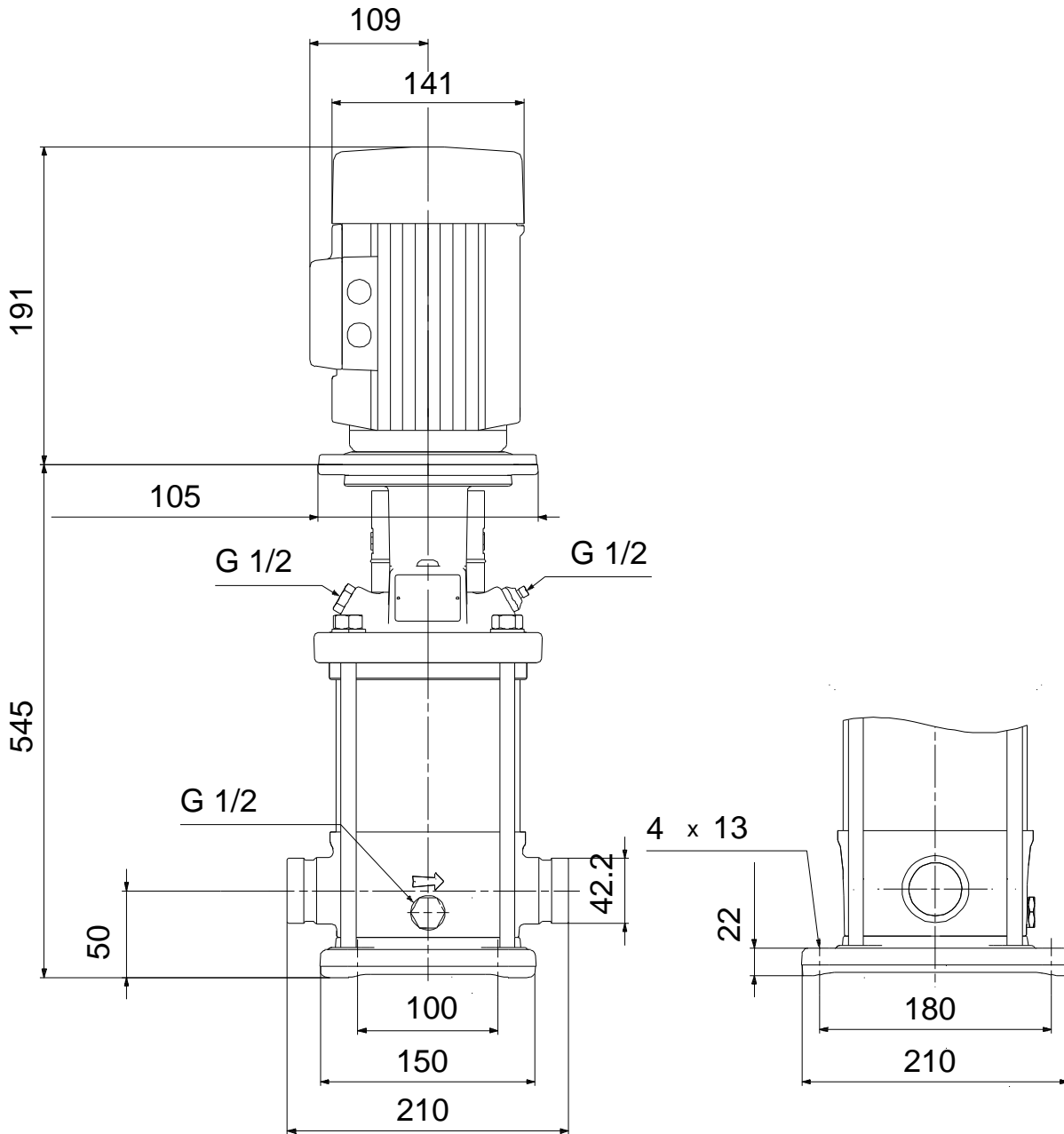

Note! All units are in [mm] unless others are stated.  
Disclaimer: This simplified dimensional drawing does not show all details.