

Position	Qty.	Description
	1	<p>UNILIFT CC7 - M1</p>  <p>Note! Product picture may differ from actual product</p> <p>Product No.: 96280979</p> <p>Grundfos Unilift CC pumps are single-stage submersible pumps with a low suction ability down to 3 mm water level.</p> <p>The pumps are designed for pumping rainwater and grey wastewater, e.g. from</p> <ul style="list-style-type: none"> • washing machines, baths, sinks, etc. from low-lying parts of buildings up to sewer level • cellars or buildings prone to flooding • draining wells • wells for surface water with inlets from roof gutters, pits, tunnels, etc. • swimming pools, ponds or fountains. <p>The pumps are suitable for both stationary and portable use. They are for manual operation. The pumps allow free passage of particles up to $\varnothing 10$ mm.</p> <p>The motor incorporates automatic overload protection cutting out the motor in case of overload. When cooled to normal temperature, the motor restarts automatically.</p> <p>Technical: Maximum particle size: 10 mm</p> <p>Materials: Pump housing: PP 15 GF Impeller: PPOm 20 GF</p> <p>Installation: Pump outlet: 1.1/4" Maximum installation depth: 10 m</p> <p>Liquid: Pumped liquid: Any Newtonian liquid Liquid temperature range: 0 .. 40 °C Density: 998.2 kg/m³</p> <p>Electrical data: Mains frequency: 50 Hz Rated voltage: 1 x 220-240 V Rated current: 1.8 A Capacitor size - run: 8 μF/450 V Enclosure class (IEC 34-5): IP68 Insulation class (IEC 85): F Length of cable: 10 m Type of cable plug: GB</p> <p>Others: Net weight: 5 kg Gross weight: 5.76 kg</p>



Company name:

Created by:

Phone:

Date:

13/06/2018

Position	Qty.	Description
		Shipping volume: 0.017 m ³

96280979 UNILIFT CC7 - M1 50 Hz

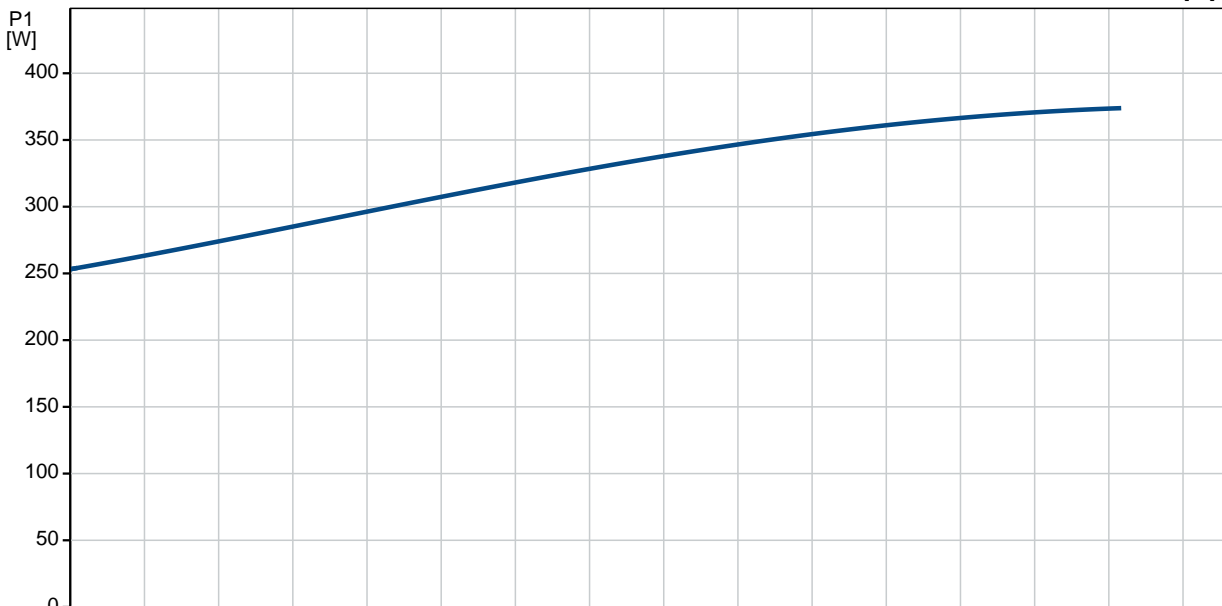
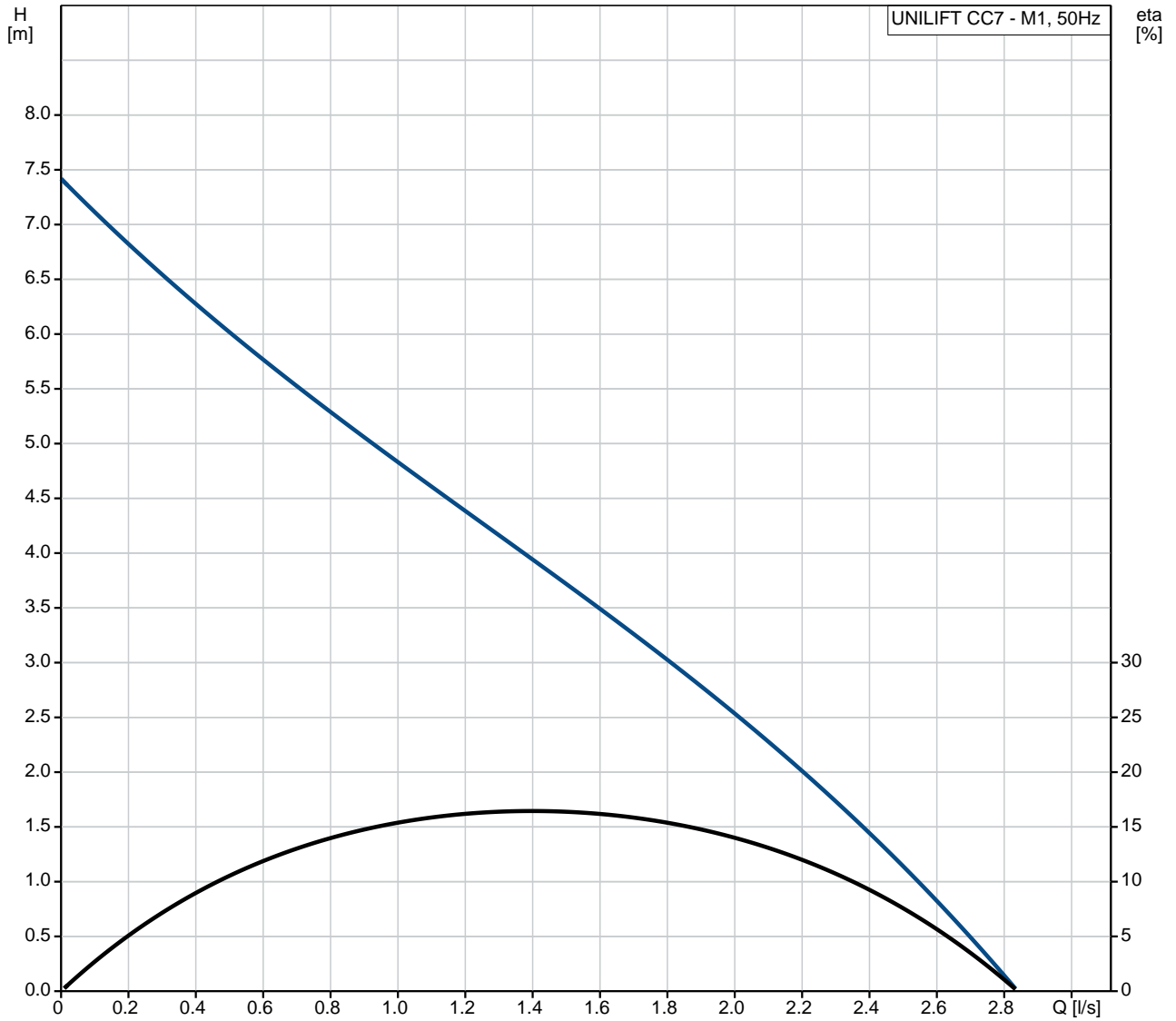

Description	Value
General information:	
Product name:	UNILIFT CC7 - M1
Product No:	96280979
EAN number:	5700830812075
Technical:	
Max flow:	2.78 l/s
Head max:	7 m
Maximum particle size:	10 mm
Materials:	
Pump housing:	PP 15 GF
Impeller:	PPOm 20 GF
Installation:	
Pump outlet:	1.1/4"
Maximum installation depth:	10 m
Liquid:	
Pumped liquid:	Any Newtonian liquid
Liquid temperature range:	0 .. 40 °C
Density:	998.2 kg/m ³
Electrical data:	
Mains frequency:	50 Hz
Rated voltage:	1 x 220-240 V
Rated current:	1.8 A
Capacitor size - run:	8 µF/450 V
Enclosure class (IEC 34-5):	IP68
Insulation class (IEC 85):	F
Motor protec:	YES
Length of cable:	10 m
Type of cable plug:	GB
Others:	
Net weight:	5 kg
Gross weight:	5.76 kg
Shipping volume:	0.017 m ³

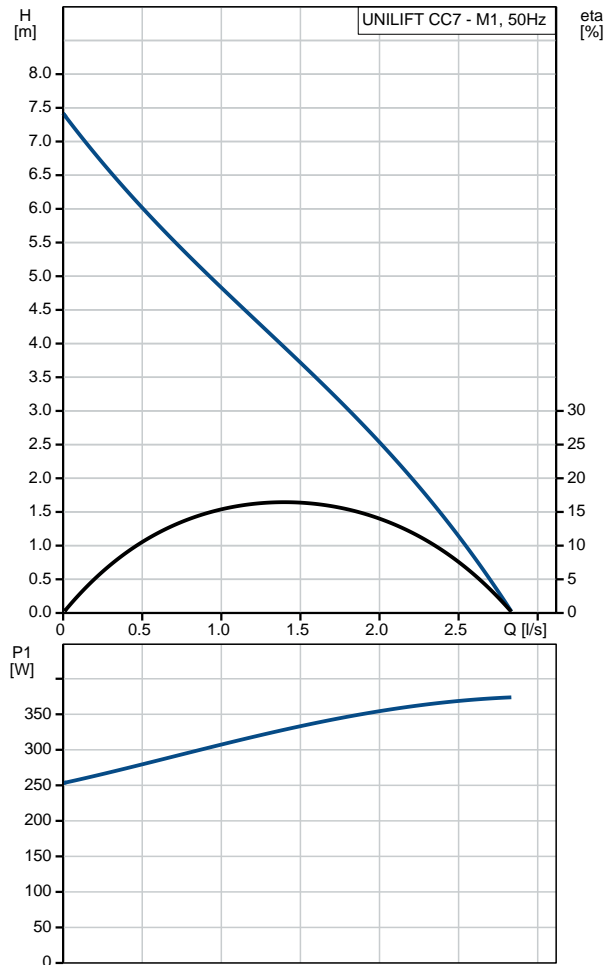

96280979 UNILIFT CC7 - M1 50 Hz

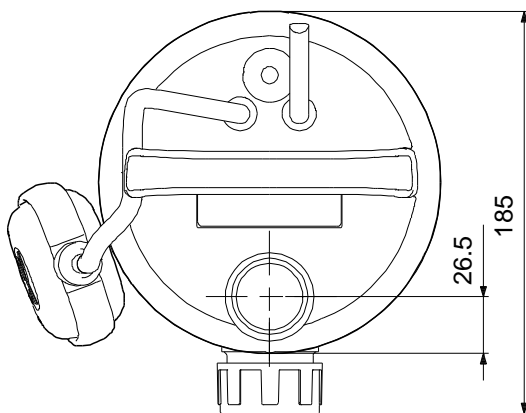
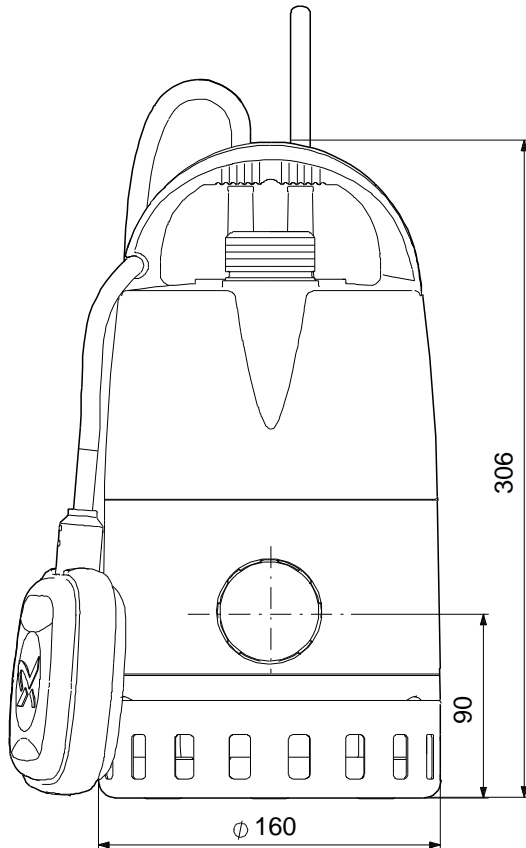

Note! All units are in [mm] unless others are stated.
Disclaimer: This simplified dimensional drawing does not show all details.

96280979 UNILIFT CC7 - M1 50 Hz

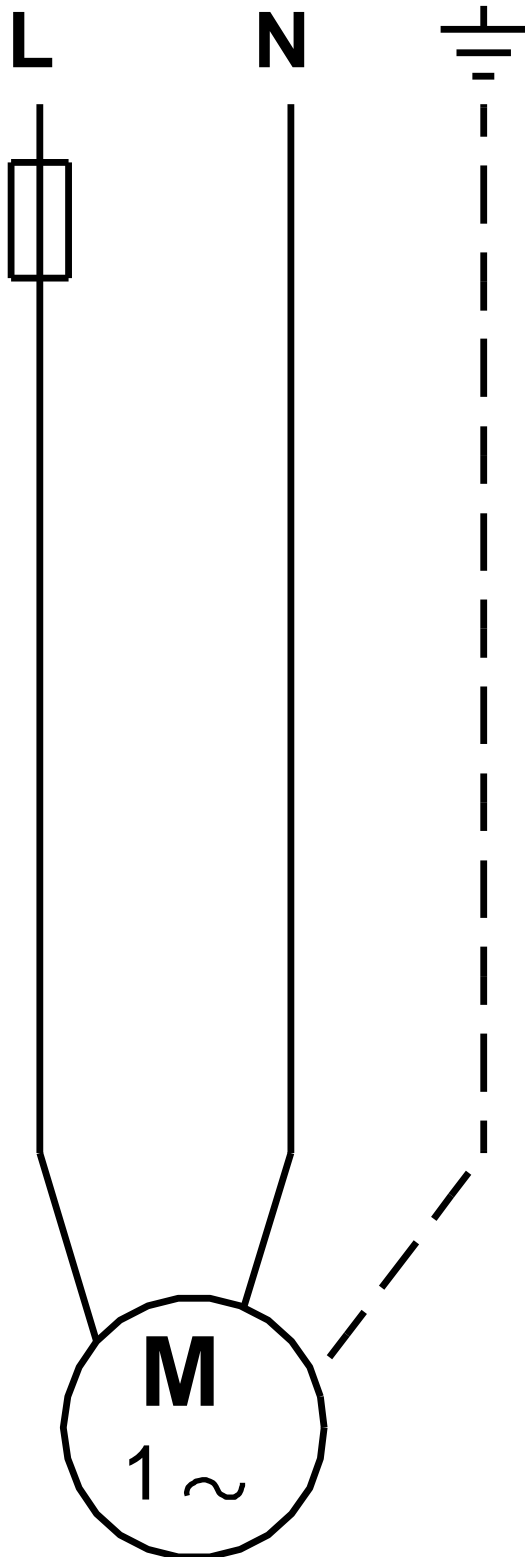

Note! All units are in [mm] unless others are stated.