

Qty.	Description
1	<p data-bbox="199 338 504 367">CRT 16-12 A-P-A-E-AUUE</p>  <p data-bbox="199 660 469 689">Product No.: 96117252</p> <p data-bbox="199 689 724 779">Vertical, non-self-priming, multistage, in-line, centrifugal pump for installation in pipe systems and mounting on a foundation.</p> <p data-bbox="199 808 679 837">The pump has the following characteristics:</p> <ul data-bbox="236 837 759 866" style="list-style-type: none"> - Impellers, intermediate chambers and outer <p data-bbox="199 866 887 896">Impeller: sleeve are made of Titanium.</p> <p data-bbox="199 896 1131 925">Pump housing: - Pump head cover and base are made of Titanium.</p> <ul data-bbox="236 925 668 954" style="list-style-type: none"> - The shaft seal has assembly length <p data-bbox="199 954 464 983">according to EN 12756.</p> <ul data-bbox="236 983 711 1048" style="list-style-type: none"> - Power transmission is via cast iron split coupling. <p data-bbox="199 1048 927 1113">Flange standard: - Pipework connection is via PJE flanges/couplings.</p> <p data-bbox="199 1135 940 1164">Phase: The motor is a 3-phase AC motor.</p> <p data-bbox="199 1193 277 1223">Liquid:</p> <p data-bbox="199 1223 635 1252">Pumped liquid: Water</p> <p data-bbox="199 1252 707 1281">Liquid temperature range: -20 .. 120 °C</p> <p data-bbox="199 1281 632 1310">Selected liquid temperature: 20 °C</p> <p data-bbox="199 1310 699 1339">Density: 998.2 kg/m³</p> <p data-bbox="199 1370 319 1400">Technical:</p> <p data-bbox="199 1400 821 1429">Pump speed on which pump data are based: 2900 rpm</p> <p data-bbox="199 1429 652 1458">Rated flow: 16 m³/h</p> <p data-bbox="199 1458 636 1487">Rated head: 133 m</p> <p data-bbox="199 1487 636 1516">Primary shaft seal: AUUE</p> <p data-bbox="199 1516 641 1545">Approvals on nameplate: CE,TR</p> <p data-bbox="199 1545 764 1574">Curve tolerance: ISO9906:2012 3B</p> <p data-bbox="199 1606 312 1635">Materials:</p> <p data-bbox="199 1635 708 1700">Pump housing: Titanium ASTM B 265</p> <p data-bbox="199 1700 708 1765">Impeller: Titanium ASTM B 265</p> <p data-bbox="199 1765 639 1794">Bush material: NONE</p> <p data-bbox="199 1825 328 1854">Installation:</p> <p data-bbox="199 1854 632 1883">Maximum ambient temperature: 60 °C</p> <p data-bbox="199 1883 734 1946">Max pressure at stated temp: 25 bar / 120 °C 25 bar / -20 °C</p> <p data-bbox="199 1946 614 1975">Flange standard: PJE</p> <p data-bbox="199 1975 663 2004">Pipe connection: 60,3 mm</p> <p data-bbox="199 2004 639 2033">Flange size for motor: FF300</p> <p data-bbox="199 2065 368 2094">Electrical data:</p>

Qty.	Description
------	-------------

Motor type:	160MB
IE Efficiency class:	IE3
Rated power - P2:	11 kW
Power (P2) required by pump:	11 kW
	11 kW
Mains frequency:	50 Hz
Rated voltage:	3 x 380-415D/660-690Y V
Rated current:	20,8-19,8/12,0-11,8 A
Starting current:	660-780 %
Cos phi - power factor:	0.88-0.84
Rated speed:	2940-2950 rpm
Efficiency:	IE3 91,2%
Motor efficiency at full load:	91.2-91.2 %
Motor efficiency at 3/4 load:	91.8 %
Motor efficiency at 1/2 load:	91.3 %
Number of poles:	2
Enclosure class (IEC 34-5):	55 Dust/Jetting
Insulation class (IEC 85):	F
Motor No:	85U17524

Others:

Minimum efficiency index, MEI $\hat{\alpha}\%$: 0.69

Net weight: 138 kg

Gross weight: 148 kg

96117252 CRT 16-12 A-P-A-E-AUUE 50 Hz

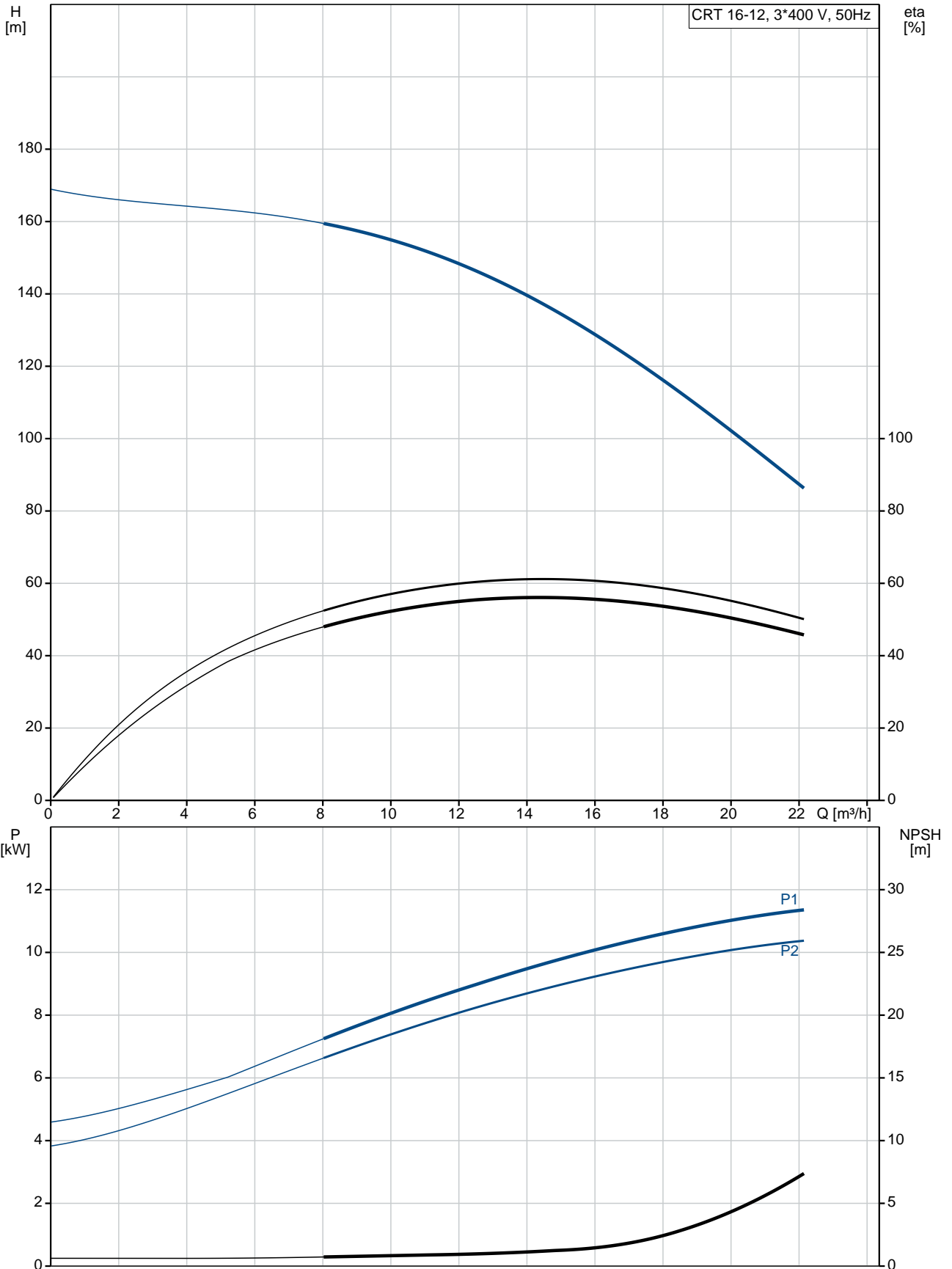

Description	Value
General information:	
Product name:	CRT 16-12 A-P-A-E-AUUE
Product No:	96117252
EAN number:	5700396596167
Price:	
Technical:	
Pump speed on which pump data are based:	2900 rpm
Rated flow:	16 m ³ /h
Rated head:	133 m
Maximum head:	173.5 m
Head max:	173.5 m
Stages:	14
Impellers:	12
Primary shaft seal:	AUUE
Approvals on nameplate:	CE, TR
Curve tolerance:	ISO9906:2012 3B
Pump version:	A
Model:	A
Materials:	
Pump housing:	Titanium
Pump housing:	ASTM B 265
Impeller:	Titanium
Impeller:	ASTM B 265
Material code:	A
Code for rubber:	E
Bush material:	NONE
Installation:	
Maximum ambient temperature:	60 °C
Max pressure at stated temp:	25 bar / 120 °C
Max pressure at stated temp:	25 bar / -20 °C
Flange standard:	PJE
Pipe connection:	60,3 mm
Flange size for motor:	FF300
Connect code:	P
Liquid:	
Pumped liquid:	Water
Liquid temperature range:	-20 .. 120 °C
Selected liquid temperature:	20 °C
Density:	998.2 kg/m ³
Electrical data:	
Motor type:	160MB
IE Efficiency class:	IE3
Rated power - P2:	11 kW
Power (P2) required by pump:	11 kW
Power (P2) required by pump:	11 kW
Mains frequency:	50 Hz
Rated voltage:	3 x 380-415D/660-690V V
Rated current:	20,8-19,8/12,0-11,8 A
Starting current:	660-780 %
Cos phi - power factor:	0.88-0.84
Rated speed:	2940-2950 rpm
Efficiency:	IE3 91,2%
Motor efficiency at full load:	91.2-91.2 %
Motor efficiency at 3/4 load:	91.8 %
Motor efficiency at 1/2 load:	91.3 %
Number of poles:	2

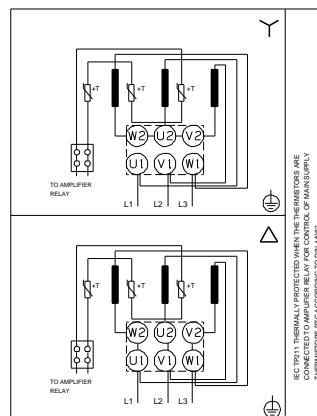
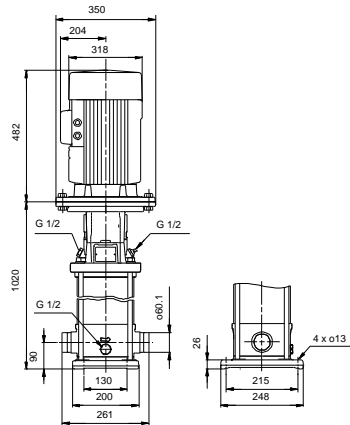
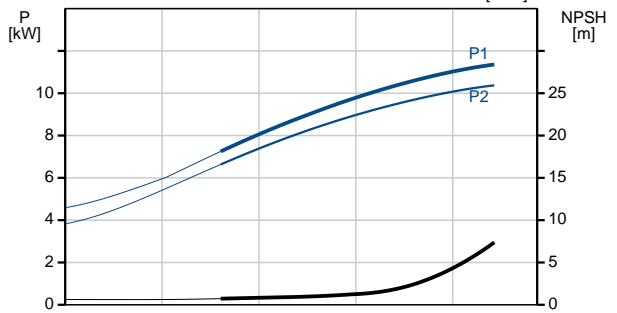
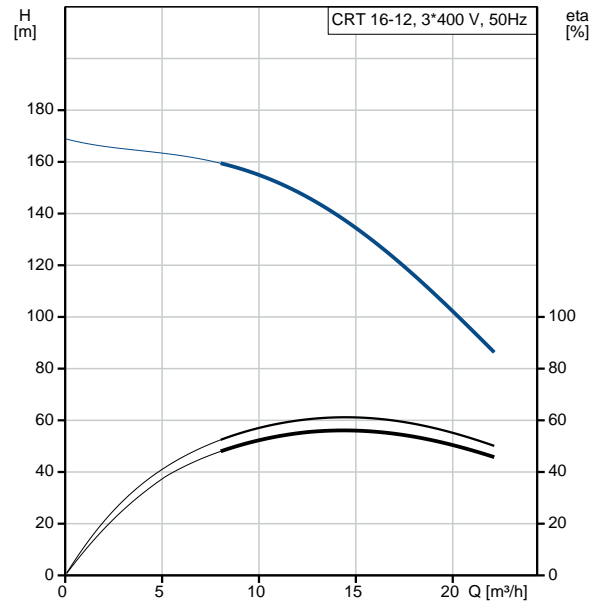



Company name:

Created by:

Phone:

Date: 19/01/2021

Description	Value
Enclosure class (IEC 34-5):	55 Dust/Jetting
Insulation class (IEC 85):	F
Motor protec:	PTC
Motor No:	85U17524
Others:	
Minimum efficiency index, MEI %:	0.69
Net weight:	138 kg
Gross weight:	148 kg

96117252 CRT 16-12 A-P-A-E-AUUE 50 Hz

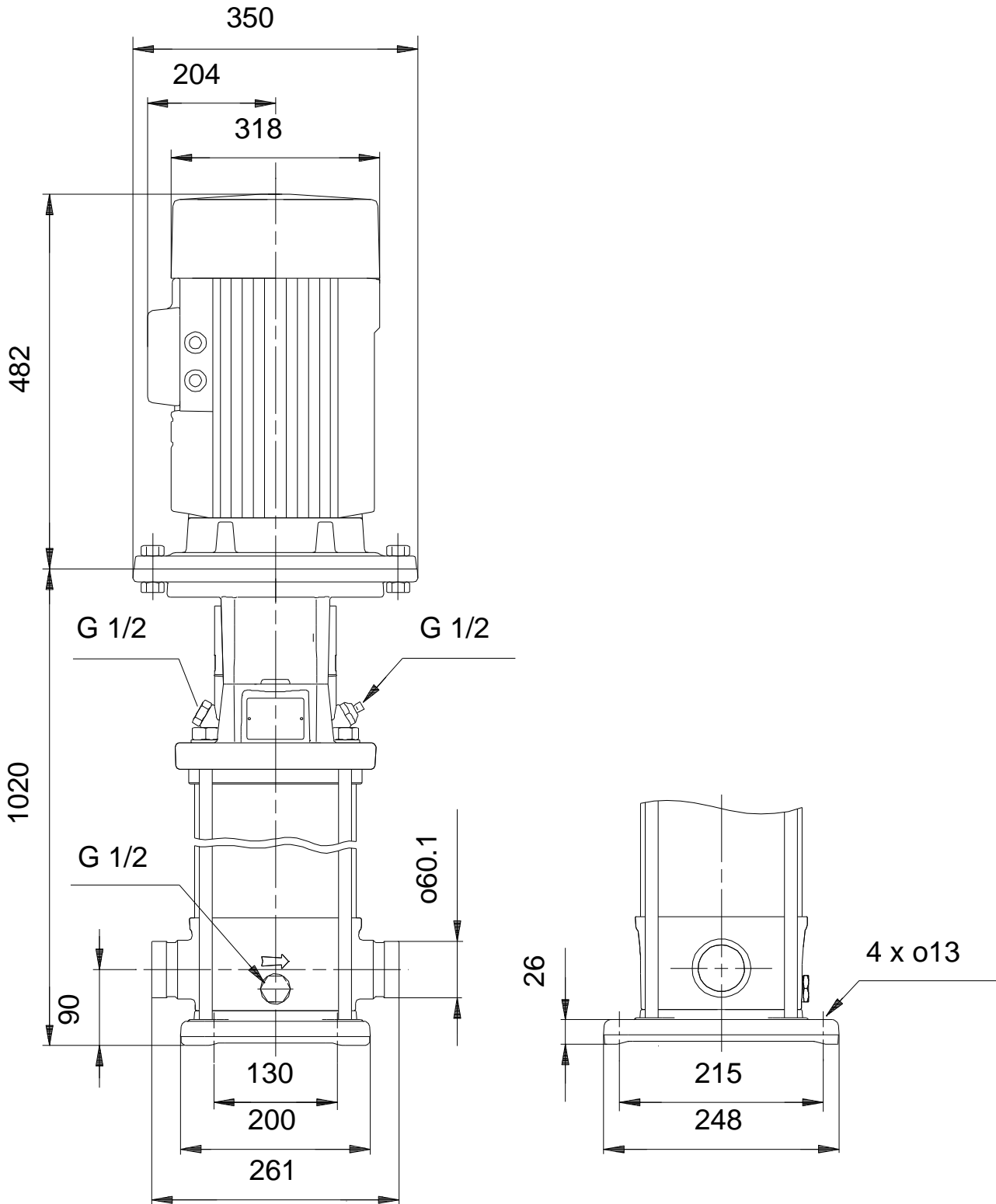

Note! All units are in [mm] unless others are stated.
Disclaimer: This simplified dimensional drawing does not show all details.

96117252 CRT 16-12 A-P-A-E-AUUE 50 Hz



IEC TP211 THERMALLY PROTECTED WHEN THE THERMISTORS ARE
CONNECTED TO AMPLIFIER RELAY FOR CONTROL OF MAIN SUPPLY
THERMISTORS PTC ACCORDING TO DIN 44082

Note! All units are in [mm] unless others are stated.