

Qty. Description

1 TP 150-60/6 A-F-A-BQQE-IX5

Product No.: [96109937](#)

Single-stage, close-coupled, volute pump with in-line suction and discharge ports of identical diameter. The pump is of the top-pull-out design, i.e. the power head (motor, pump head and impeller) can be removed for maintenance or service while the pump housing remains in the pipework.

The pump is fitted with an unbalanced rubber bellows seal. The shaft seal is according to EN 12756. Pipework connection is via PN 16 DIN flanges (EN 1092-2 and ISO 7005-2).

Pipework connection is via PN 16 DIN flanges (EN 1092-2 and ISO 7005-2).

The pump is fitted with a fan-cooled asynchronous motor.

Liquid:

Pumped liquid: Water
Liquid temperature range: -25 .. 120 °C
Selected liquid temperature: 20 °C
Density: 998.2 kg/m³

Technical:

Pump speed on which pump data are based: 970 rpm
Rated flow: 136 m³/h
Rated head: 4.09 m
Actual impeller diameter: 200 mm
Primary shaft seal: BQQE
Curve tolerance: ISO9906:2012 3B2

Materials:

Pump housing: Cast iron
EN-JL1040
ASTM A48-40 B
Impeller: Cast iron
EN-JL1030
ASTM A48-30 B

Installation:

Range of ambient temperature: -20 .. 55 °C
Maximum operating pressure: 16 bar
Flange standard: DIN
Pipe connection: DN 150
Pump inlet: DN 150
Pump outlet: DN 150
Pressure rating: PN 16
Port-to-port length: 800 mm
Flange size for motor: FF215

Electrical data:

Motor type: SIEMENS
IE Efficiency class: IE3
Rated power - P2: 2.2 kW
Power (P2) required by pump: 2.2 kW

Qty.	Description
	<p>Mains frequency: 50 Hz Rated voltage: 3 x 220-240D/380-420Y V Rated current: 9,15-8,30/5,30-4,80 A Starting current: 680-680 % Cos phi - power factor: 0.8 Rated speed: 970 rpm Efficiency: IE3 84,3% Motor efficiency at full load: 84.3-84.3 % Motor efficiency at 3/4 load: 84.9-84.9 % Motor efficiency at 1/2 load: 83.6-83.6 % Number of poles: 6 Enclosure class (IEC 34-5): 55 Dust/Jetting Insulation class (IEC 85): F Motor No: 83W02208</p> <p>Others: Minimum efficiency index, MEI η_{min}: 0.62 ErP status: EuP Standalone/Prod. Net weight: 227 kg Gross weight: 260 kg Shipping volume: 0.75 m³ Danish VVS No.: 381728060 Country of origin: HU Custom tariff no.: 84137051</p>

96109937 TP 150-60/6 A-F-A-BQQE-IX5 50 Hz

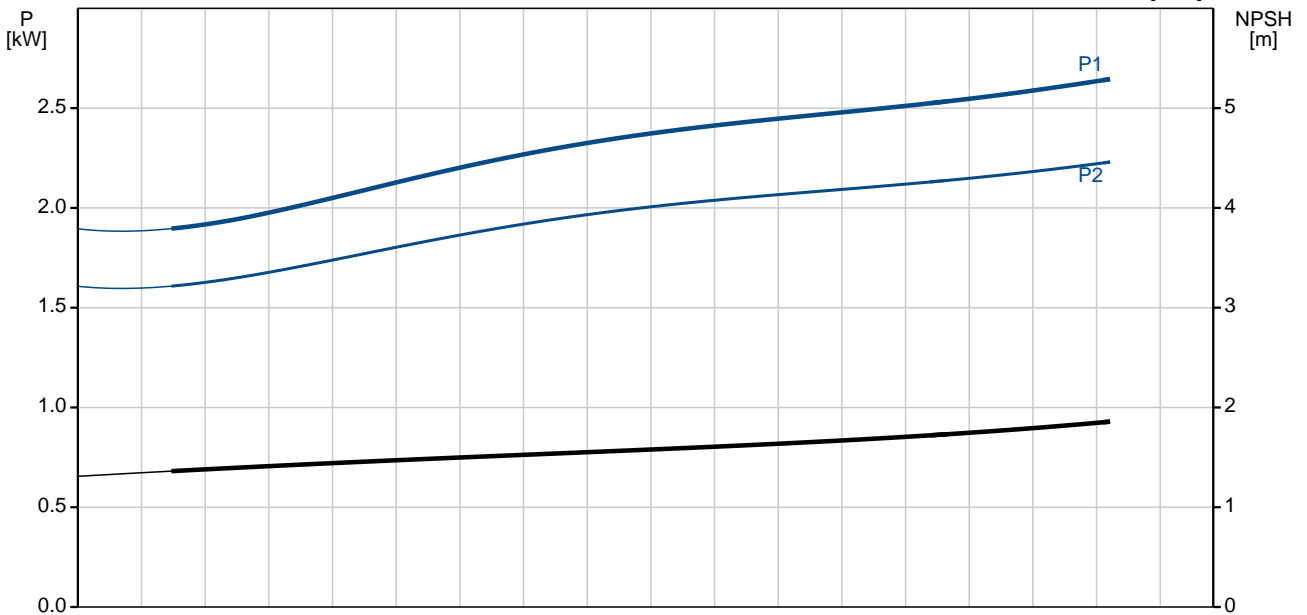
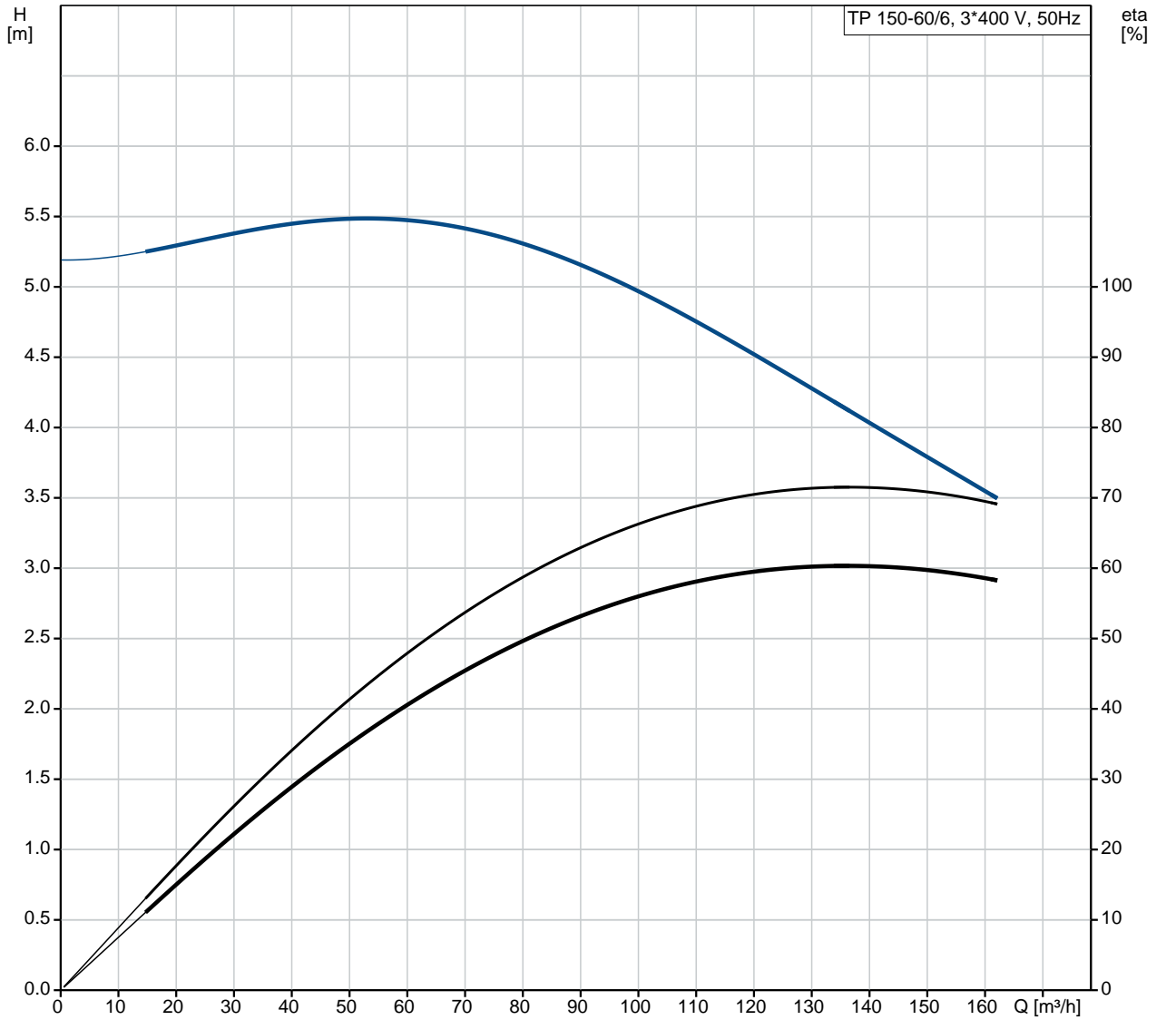

Description	Value
General information:	
Product name:	TP 150-60/6 A-F-A-BQQE-IX5
Product No:	96109937
EAN number:	5700396989228
Price:	3.772,00 GBP
Technical:	
Pump speed on which pump data are based:	970 rpm
Rated flow:	136 m ³ /h
Rated head:	4.09 m
Head max:	60 dm
Actual impeller diameter:	200 mm
Primary shaft seal:	BQQE
Curve tolerance:	ISO9906:2012 3B2
Pump version:	A
Model:	A
Materials:	
Pump housing:	Cast iron EN-JL1040 ASTM A48-40 B
Impeller:	Cast iron EN-JL1030 ASTM A48-30 B
Material code:	A
Installation:	
Range of ambient temperature:	-20 .. 55 °C
Maximum operating pressure:	16 bar
Flange standard:	DIN
Pipe connection:	DN 150
Pump inlet:	DN 150
Pump outlet:	DN 150
Pressure rating:	PN 16
Port-to-port length:	800 mm
Flange size for motor:	FF215
Connect code:	F
Liquid:	
Pumped liquid:	Water
Liquid temperature range:	-25 .. 120 °C
Selected liquid temperature:	20 °C
Density:	998.2 kg/m ³
Electrical data:	
Motor type:	SIEMENS
IE Efficiency class:	IE3
Rated power - P2:	2.2 kW
Power (P2) required by pump:	2.2 kW
Mains frequency:	50 Hz
Rated voltage:	3 x 220-240D/380-420Y V
Rated current:	9,15-8,30/5,30-4,80 A
Starting current:	680-680 %
Cos phi - power factor:	0.8
Rated speed:	970 rpm
Efficiency:	IE3 84,3%
Motor efficiency at full load:	84.3-84.3 %
Motor efficiency at 3/4 load:	84.9-84.9 %
Motor efficiency at 1/2 load:	83.6-83.6 %
Number of poles:	6

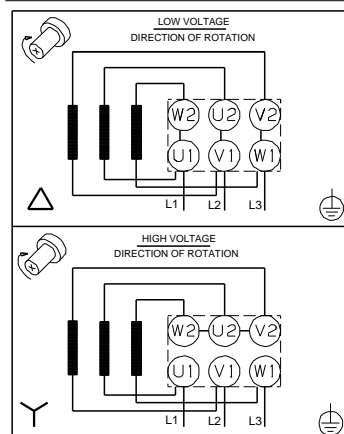
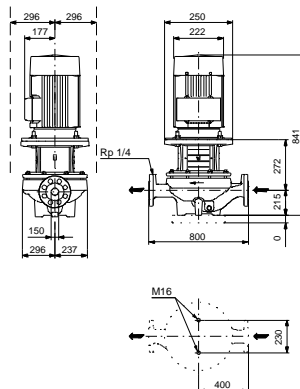
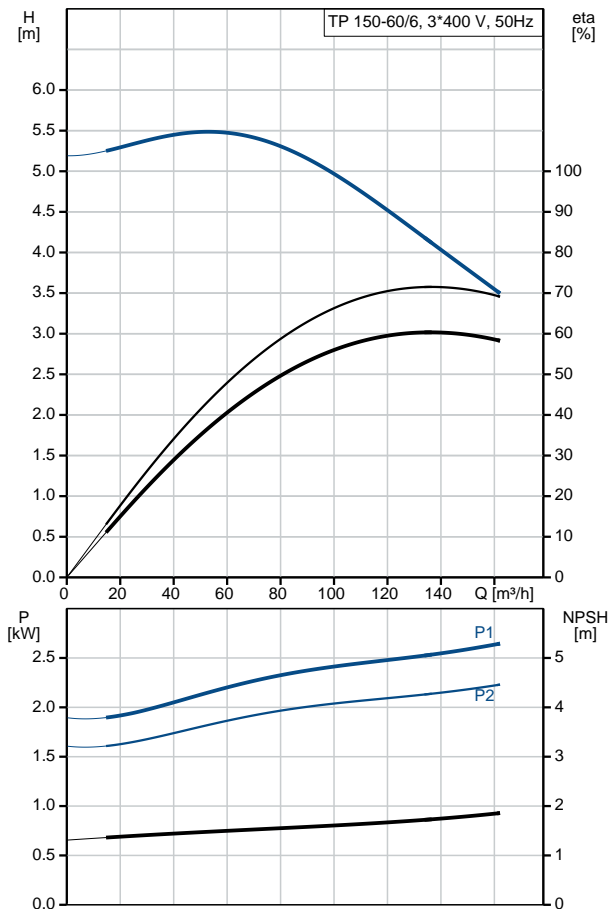



Company name:

Created by:

Phone:

Date:

10/03/2020

Description	Value
Enclosure class (IEC 34-5):	55 Dust/Jetting
Insulation class (IEC 85):	F
Motor protec:	NONE
Motor No:	83W02208
Others:	
Minimum efficiency index, MEI %:	0.62
ErP status:	EuP Standalone/Prod.
Net weight:	227 kg
Gross weight:	260 kg
Shipping volume:	0.75 m ³
Danish VVS No.:	381728060
Country of origin:	HU
Custom tariff no.:	84137051

96109937 TP 150-60/6 A-F-A-BQQE-IX5 50 Hz

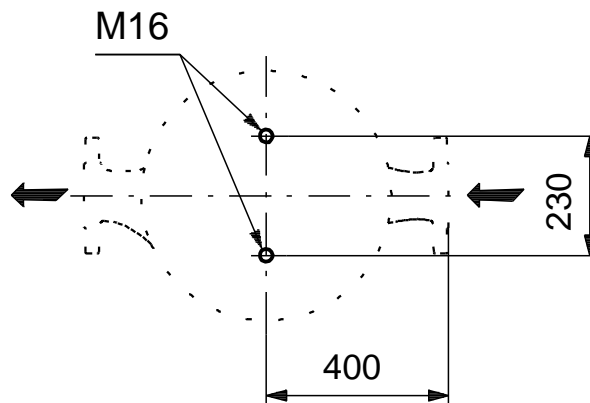
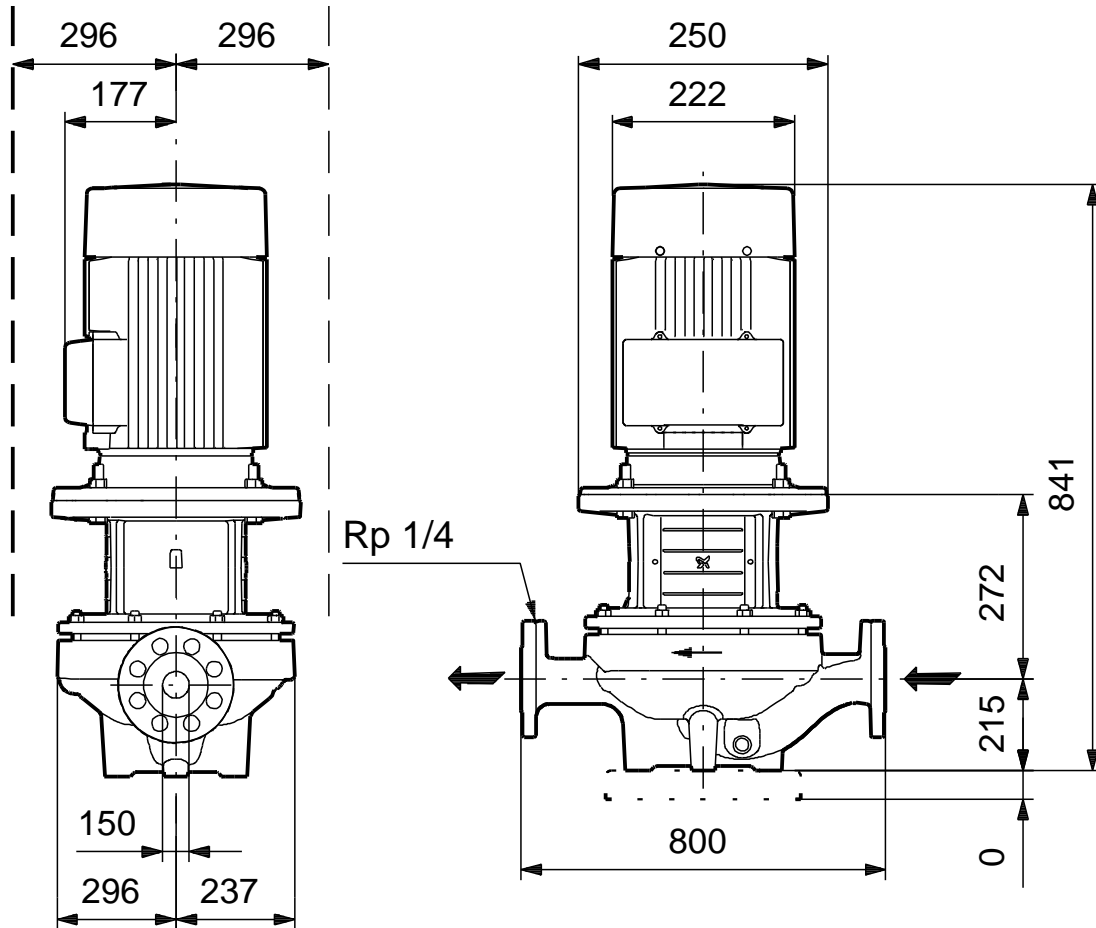

Note! All units are in [mm] unless others are stated.
Disclaimer: This simplified dimensional drawing does not show all details.