

Qty.	Description
1	<p data-bbox="199 338 478 369"><b>CRT 8-8 A-P-A-E-AUUE</b></p>  <p data-bbox="199 660 470 689">Product No.: <a href="#">96108245</a></p> <p data-bbox="199 689 726 779">Vertical, non-self-priming, multistage, in-line, centrifugal pump for installation in pipe systems and mounting on a foundation.</p> <p data-bbox="199 808 678 837">The pump has the following characteristics:</p> <ul data-bbox="236 837 758 866" style="list-style-type: none"> <li>- Impellers, intermediate chambers and outer</li> </ul> <p data-bbox="199 866 885 896">Impeller: sleeve are made of Titanium.</p> <p data-bbox="199 896 1133 925">Pump housing: - Pump head cover and base are made of Titanium.</p> <ul data-bbox="236 925 670 954" style="list-style-type: none"> <li>- The shaft seal has assembly length</li> </ul> <p data-bbox="199 954 462 983">according to EN 12756.</p> <ul data-bbox="236 983 710 1048" style="list-style-type: none"> <li>- Power transmission is via cast iron split coupling.</li> </ul> <p data-bbox="199 1048 925 1113">Flange standard: - Pipework connection is via PJE flanges/couplings.</p> <p data-bbox="199 1135 941 1164">Phase: The motor is a 3-phase AC motor.</p> <p data-bbox="199 1193 279 1223">Liquid:</p> <p data-bbox="199 1223 630 1252">Pumped liquid: Water</p> <p data-bbox="199 1252 710 1281">Liquid temperature range: -20 .. 120 °C</p> <p data-bbox="199 1281 630 1310">Selected liquid temperature: 20 °C</p> <p data-bbox="199 1310 694 1339">Density: 998.2 kg/m<sup>3</sup></p> <p data-bbox="199 1370 319 1400">Technical:</p> <p data-bbox="199 1400 821 1429">Pump speed on which pump data are based: 2900 rpm</p> <p data-bbox="199 1429 662 1458">Rated flow: 9.5 m<sup>3</sup>/h</p> <p data-bbox="199 1458 646 1487">Rated head: 65.4 m</p> <p data-bbox="199 1487 630 1516">Primary shaft seal: AUUE</p> <p data-bbox="199 1516 646 1545">Approvals on nameplate: CE,TR</p> <p data-bbox="199 1545 766 1574">Curve tolerance: ISO9906:2012 3B</p> <p data-bbox="199 1606 311 1635">Materials:</p> <p data-bbox="199 1635 710 1700">Pump housing: Titanium ASTM B 265</p> <p data-bbox="199 1700 710 1765">Impeller: Titanium ASTM B 265</p> <p data-bbox="199 1765 638 1794">Bush material: NONE</p> <p data-bbox="199 1825 327 1854">Installation:</p> <p data-bbox="199 1854 630 1883">Maximum ambient temperature: 60 °C</p> <p data-bbox="199 1883 734 1946">Max pressure at stated temp: 25 bar / 120 °C 25 bar / -20 °C</p> <p data-bbox="199 1946 614 1975">Flange standard: PJE</p> <p data-bbox="199 1975 662 2004">Pipe connection: 60,3 mm</p> <p data-bbox="199 2004 638 2033">Flange size for motor: FT130</p> <p data-bbox="199 2065 367 2094">Electrical data:</p>

Qty.	Description
	<p>Motor type: 100LC IE Efficiency class: IE3 Rated power - P2: 3 kW Power (P2) required by pump: 3 kW 3 kW Mains frequency: 50 Hz Rated voltage: 3 x 220-240D/380-415Y V Rated current: 11.0/6.30 A Starting current: 840-920 % Cos phi - power factor: 0.87-0.82 Rated speed: 2900-2920 rpm Efficiency: IE3 87,1% Motor efficiency at full load: 87.1 % Motor efficiency at 3/4 load: 88.0 % Motor efficiency at 1/2 load: 87.7 % Number of poles: 2 Enclosure class (IEC 34-5): 55 Dust/Jetting Insulation class (IEC 85): F Motor No: 85U05510</p> <p>Others: Minimum efficiency index, MEI <math>\hat{\alpha}\%</math>: 0.7 Net weight: 46 kg Gross weight: 56 kg</p>

## 96108245 CRT 8-8 A-P-A-E-AUUE 50 Hz

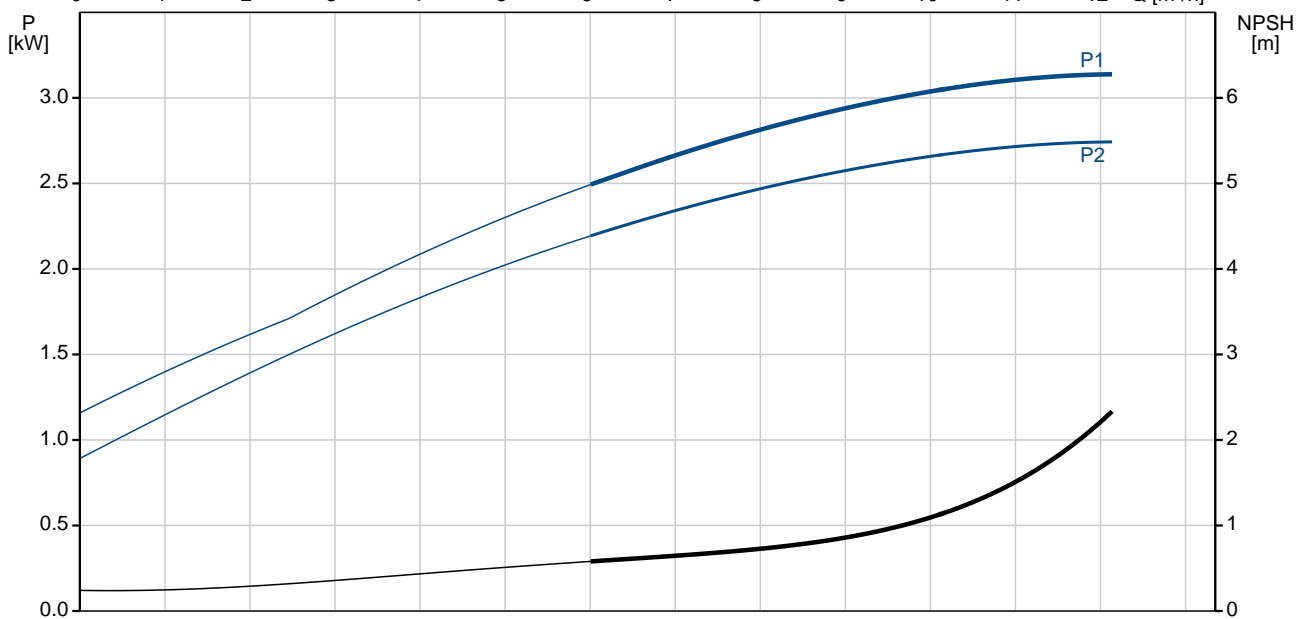
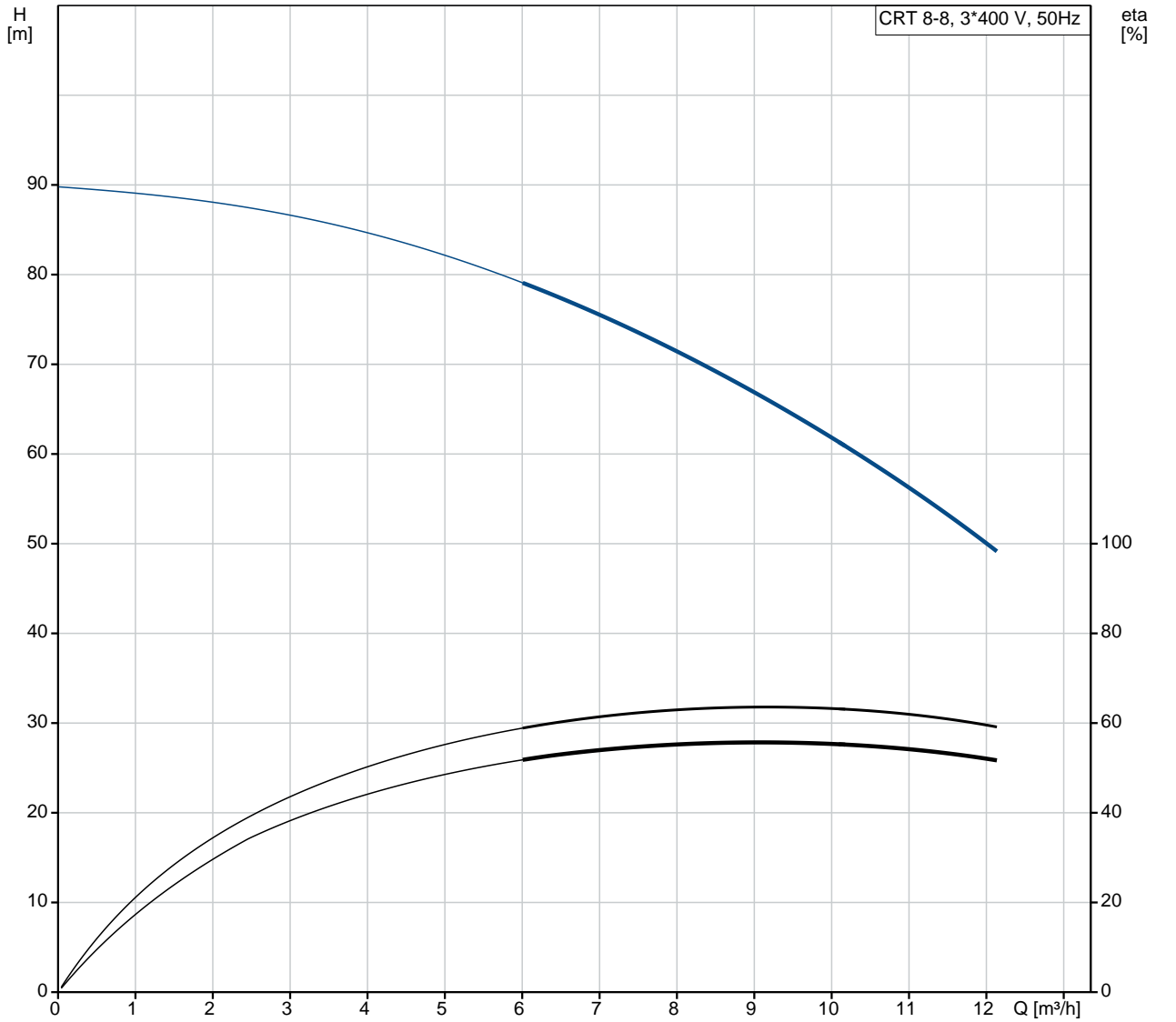

Description	Value
<b>General information:</b>	
Product name:	CRT 8-8 A-P-A-E-AUUE
Product No:	96108245
EAN number:	5700396401249
Price:	
<b>Technical:</b>	
Pump speed on which pump data are based:	2900 rpm
Rated flow:	9.5 m <sup>3</sup> /h
Rated head:	65.4 m
Maximum head:	87.6 m
Head max:	87.6 m
Stages:	10
Impellers:	8
Primary shaft seal:	AUUE
Approvals on nameplate:	CE,TR
Curve tolerance:	ISO9906:2012 3B
Pump version:	A
Model:	A
<b>Materials:</b>	
Pump housing:	Titanium
Pump housing:	ASTM B 265
Impeller:	Titanium
Impeller:	ASTM B 265
Material code:	A
Code for rubber:	E
Bush material:	NONE
<b>Installation:</b>	
Maximum ambient temperature:	60 °C
Max pressure at stated temp:	25 bar / 120 °C
Max pressure at stated temp:	25 bar / -20 °C
Flange standard:	PJE
Pipe connection:	60,3 mm
Flange size for motor:	FT130
Connect code:	P
<b>Liquid:</b>	
Pumped liquid:	Water
Liquid temperature range:	-20 .. 120 °C
Selected liquid temperature:	20 °C
Density:	998.2 kg/m <sup>3</sup>
<b>Electrical data:</b>	
Motor type:	100LC
IE Efficiency class:	IE3
Rated power - P2:	3 kW
Power (P2) required by pump:	3 kW
Power (P2) required by pump:	3 kW
Mains frequency:	50 Hz
Rated voltage:	3 x 220-240D/380-415Y V
Rated current:	11.0/6.30 A
Starting current:	840-920 %
Cos phi - power factor:	0.87-0.82
Rated speed:	2900-2920 rpm
Efficiency:	IE3 87,1%
Motor efficiency at full load:	87.1 %
Motor efficiency at 3/4 load:	88.0 %
Motor efficiency at 1/2 load:	87.7 %
Number of poles:	2

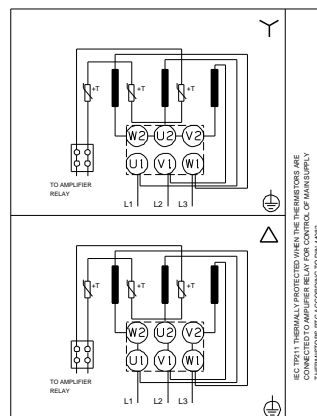
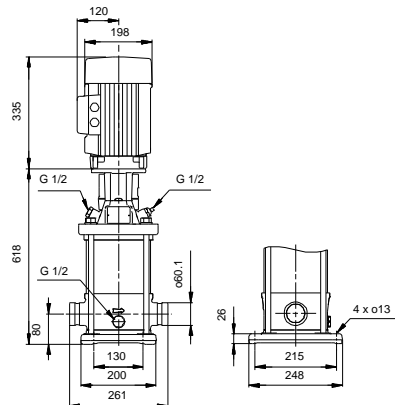
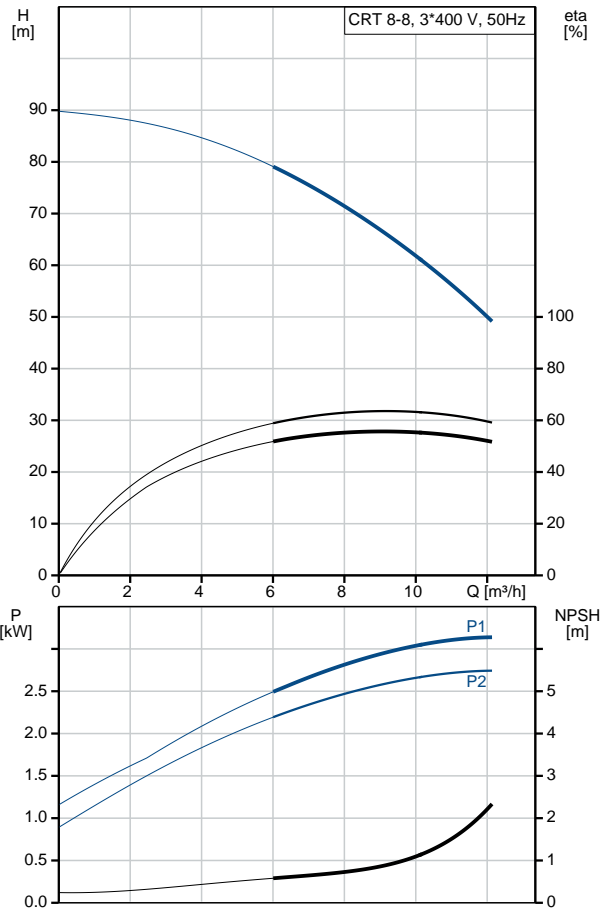



Company name:

Created by:

Phone:

Date:

19/01/2021

Description	Value
Enclosure class (IEC 34-5):	55 Dust/Jetting
Insulation class (IEC 85):	F
Motor protec:	PTC
Motor No:	85U05510
<b>Others:</b>	
Minimum efficiency index, MEI %:	0.7
Net weight:	46 kg
Gross weight:	56 kg

## 96108245 CRT 8-8 A-P-A-E-AUUE 50 Hz

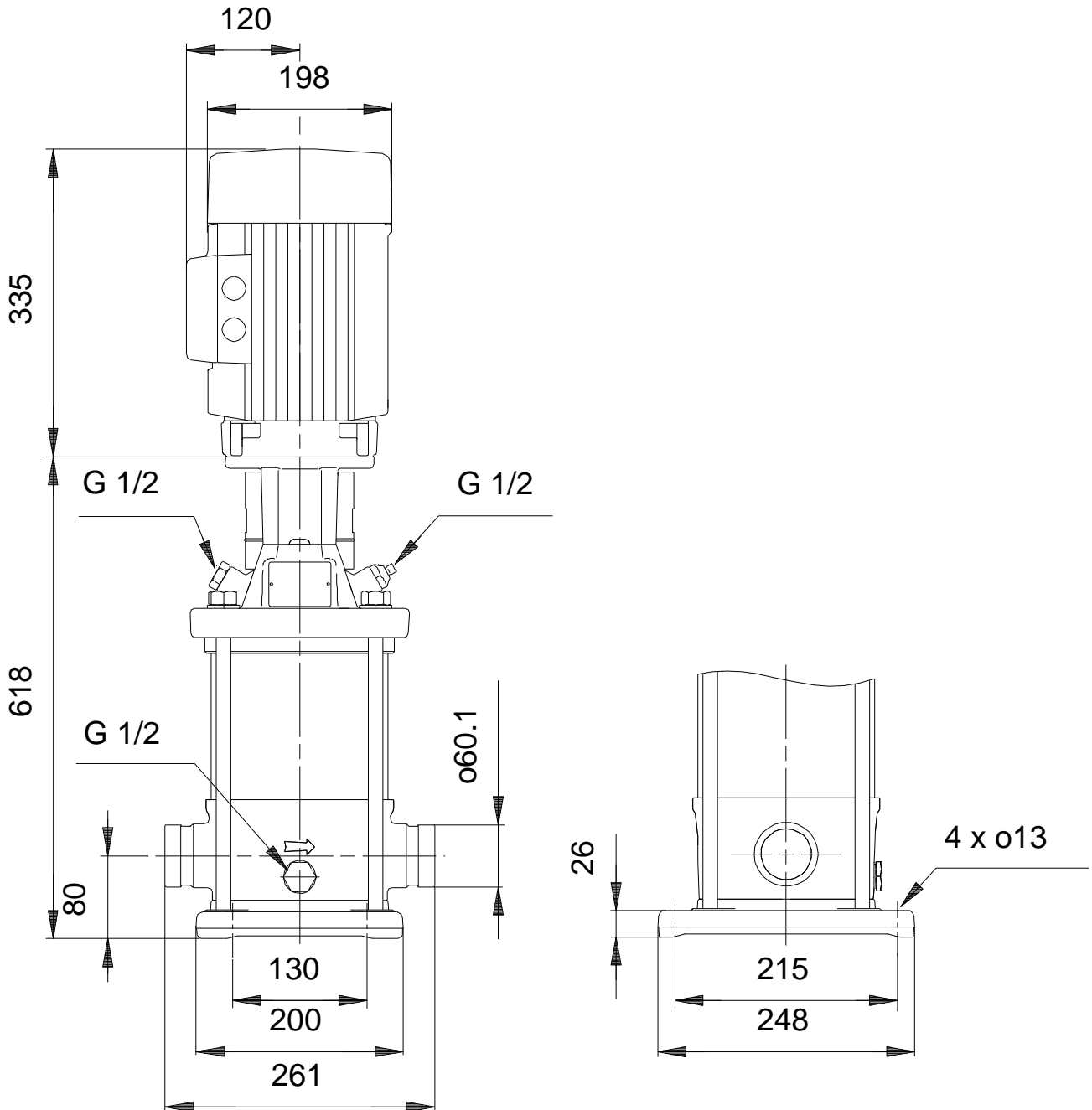

Note! All units are in [mm] unless others are stated.  
Disclaimer: This simplified dimensional drawing does not show all details.

## 96108245 CRT 8-8 A-P-A-E-AUUE 50 Hz

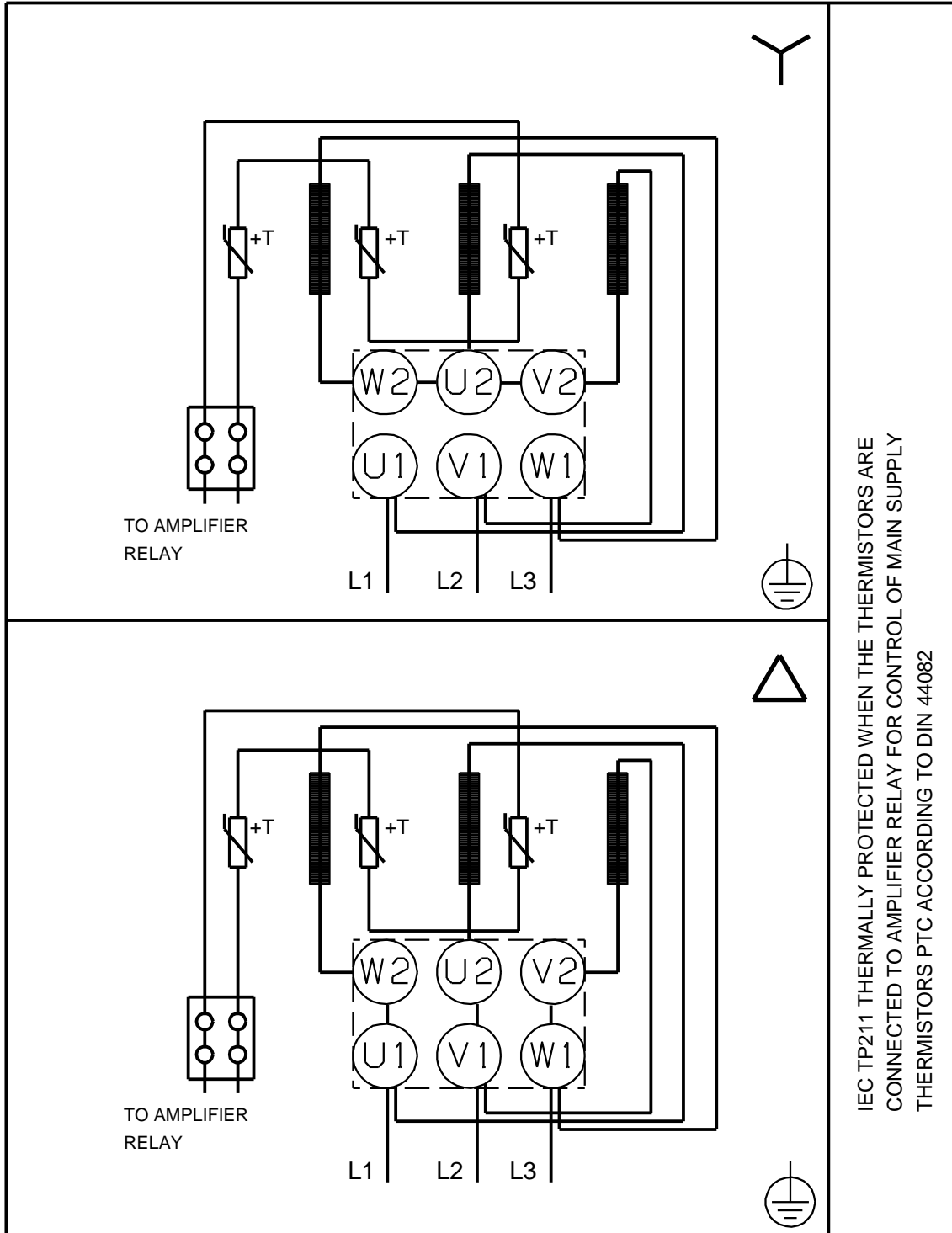

IEC TP211 THERMALLY PROTECTED WHEN THE THERMISTORS ARE  
CONNECTED TO AMPLIFIER RELAY FOR CONTROL OF MAIN SUPPLY  
THERMISTORS PTC ACCORDING TO DIN 44082

Note! All units are in [mm] unless others are stated.