

Qty.	Description
1	<p data-bbox="204 340 491 369">CRT 2-18 A-P-A-E-AUUE</p>  <p data-bbox="204 663 466 692">Product No.: 96100311</p> <p data-bbox="204 692 724 779">Vertical, non-self-priming, multistage, in-line, centrifugal pump for installation in pipe systems and mounting on a foundation.</p> <p data-bbox="204 810 679 840">The pump has the following characteristics:</p> <ul data-bbox="240 840 759 869" style="list-style-type: none"> - Impellers, intermediate chambers and outer <p data-bbox="204 869 884 898">Impeller: sleeve are made of Titanium.</p> <p data-bbox="204 898 1131 927">Pump housing: - Pump head cover and base are made of Titanium.</p> <ul data-bbox="240 927 668 956" style="list-style-type: none"> - The shaft seal has assembly length <p data-bbox="204 956 462 985">according to EN 12756.</p> <ul data-bbox="240 985 711 1046" style="list-style-type: none"> - Power transmission is via cast iron split coupling. <p data-bbox="204 1046 925 1106">Flange standard: - Pipework connection is via PJE flanges/couplings.</p> <p data-bbox="204 1137 940 1167">Phase: The motor is a 3-phase AC motor.</p> <p data-bbox="204 1198 277 1227">Liquid:</p> <p data-bbox="204 1227 635 1256">Pumped liquid: Water</p> <p data-bbox="204 1256 707 1285">Liquid temperature range: -20 .. 120 °C</p> <p data-bbox="204 1285 632 1314">Selected liquid temperature: 20 °C</p> <p data-bbox="204 1314 699 1344">Density: 998.2 kg/m³</p> <p data-bbox="204 1375 319 1404">Technical:</p> <p data-bbox="204 1404 820 1433">Pump speed on which pump data are based: 2900 rpm</p> <p data-bbox="204 1433 659 1462">Rated flow: 2.5 m³/h</p> <p data-bbox="204 1462 635 1491">Rated head: 104 m</p> <p data-bbox="204 1491 635 1520">Primary shaft seal: AUUE</p> <p data-bbox="204 1520 639 1550">Approvals on nameplate: CE,TR</p> <p data-bbox="204 1550 764 1579">Curve tolerance: ISO9906:2012 3B</p> <p data-bbox="204 1610 312 1639">Materials:</p> <p data-bbox="204 1639 708 1700">Pump housing: Titanium ASTM B 265</p> <p data-bbox="204 1700 708 1760">Impeller: Titanium ASTM B 265</p> <p data-bbox="204 1760 639 1789">Bush material: NONE</p> <p data-bbox="204 1821 330 1850">Installation:</p> <p data-bbox="204 1850 632 1879">Maximum ambient temperature: 60 °C</p> <p data-bbox="204 1879 734 1939">Max pressure at stated temp: 25 bar / 120 °C 25 bar / -20 °C</p> <p data-bbox="204 1939 614 1968">Flange standard: PJE</p> <p data-bbox="204 1968 663 1998">Pipe connection: 42,4 mm</p> <p data-bbox="204 1998 639 2027">Flange size for motor: FT115</p> <p data-bbox="204 2058 367 2087">Electrical data:</p>

Qty.	Description
	<p>Motor type: 90LE</p> <p>IE Efficiency class: IE3</p> <p>Rated power - P2: 2.2 kW</p> <p>Power (P2) required by pump: 2.2 kW</p> <p>Mains frequency: 50 Hz</p> <p>Rated voltage: 3 x 220-240D/380-415Y V</p> <p>Rated current: 8.00/4.60 A</p> <p>Starting current: 840-920 %</p> <p>Cos phi - power factor: 0.86-0.80</p> <p>Rated speed: 2890-2910 rpm</p> <p>Efficiency: IE3 85,9%</p> <p>Motor efficiency at full load: 85.9-85.9 %</p> <p>Motor efficiency at 3/4 load: 88.2 %</p> <p>Motor efficiency at 1/2 load: 88.0 %</p> <p>Number of poles: 2</p> <p>Enclosure class (IEC 34-5): 55 Dust/Jetting</p> <p>Insulation class (IEC 85): F</p> <p>Motor No: 85U01908</p> <p>Others:</p> <p>Minimum efficiency index, MEI $\hat{\alpha}\%$: 0.7</p> <p>Net weight: 36.9 kg</p> <p>Gross weight: 41.9 kg</p>

96100311 CRT 2-18 A-P-A-E-AUUE 50 Hz

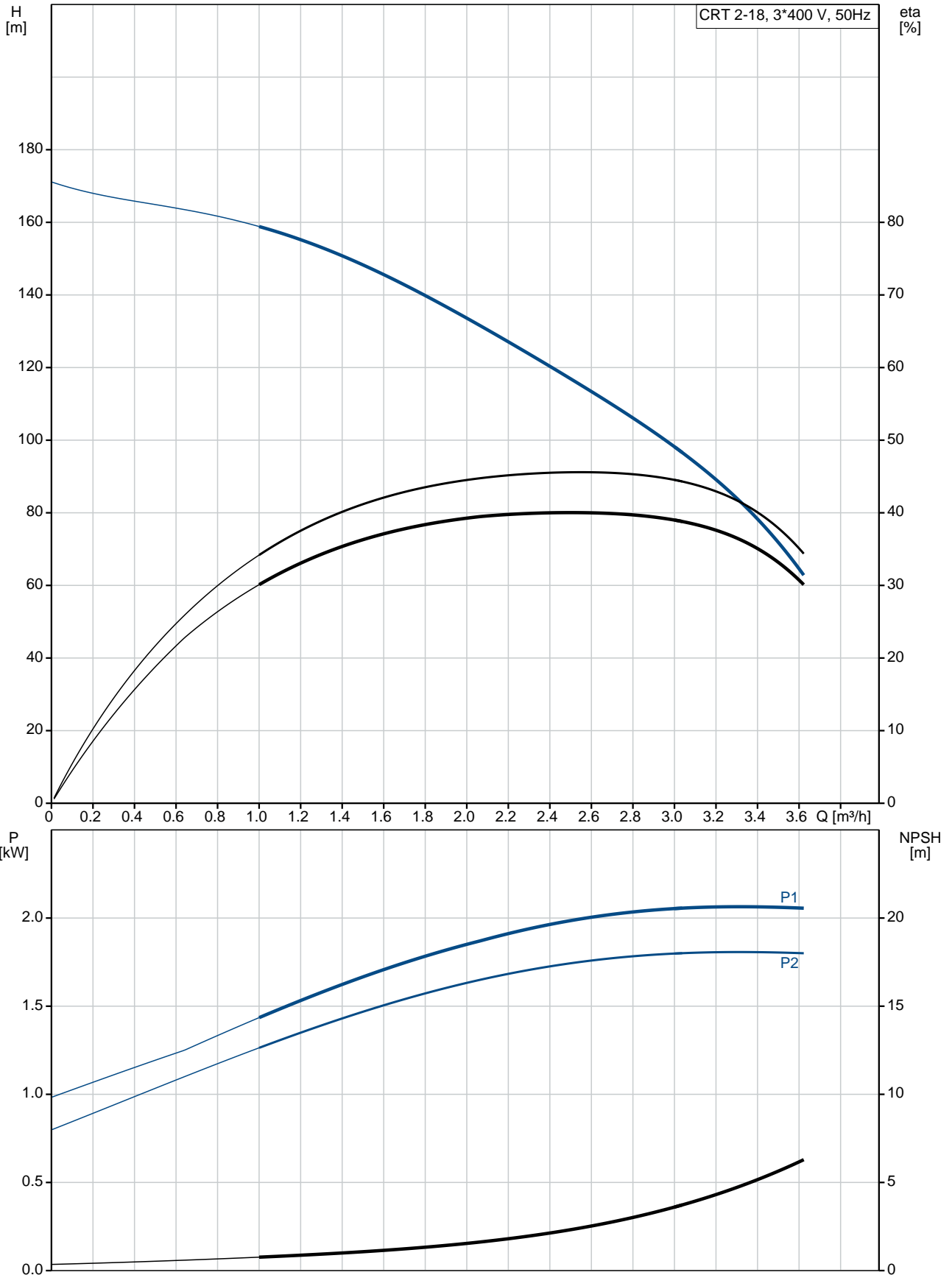

Description	Value
General information:	
Product name:	CRT 2-18 A-P-A-E-AUUE
Product No:	96100311
EAN number:	5700395842692
Price:	
Technical:	
Pump speed on which pump data are based:	2900 rpm
Rated flow:	2.5 m ³ /h
Rated head:	104 m
Maximum head:	169 m
Head max:	169 m
Stages:	18
Impellers:	18
Primary shaft seal:	AUUE
Approvals on nameplate:	CE, TR
Curve tolerance:	ISO9906:2012 3B
Pump version:	A
Model:	A
Materials:	
Pump housing:	Titanium
Pump housing:	ASTM B 265
Impeller:	Titanium
Impeller:	ASTM B 265
Material code:	A
Code for rubber:	E
Bush material:	NONE
Installation:	
Maximum ambient temperature:	60 °C
Max pressure at stated temp:	25 bar / 120 °C
Max pressure at stated temp:	25 bar / -20 °C
Flange standard:	PJE
Pipe connection:	42,4 mm
Flange size for motor:	FT115
Connect code:	P
Liquid:	
Pumped liquid:	Water
Liquid temperature range:	-20 .. 120 °C
Selected liquid temperature:	20 °C
Density:	998.2 kg/m ³
Electrical data:	
Motor type:	90LE
IE Efficiency class:	IE3
Rated power - P2:	2.2 kW
Power (P2) required by pump:	2.2 kW
Power (P2) required by pump:	2.2 kW
Mains frequency:	50 Hz
Rated voltage:	3 x 220-240D/380-415Y V
Rated current:	8.00/4.60 A
Starting current:	840-920 %
Cos phi - power factor:	0.86-0.80
Rated speed:	2890-2910 rpm
Efficiency:	IE3 85,9%
Motor efficiency at full load:	85.9-85.9 %
Motor efficiency at 3/4 load:	88.2 %
Motor efficiency at 1/2 load:	88.0 %
Number of poles:	2

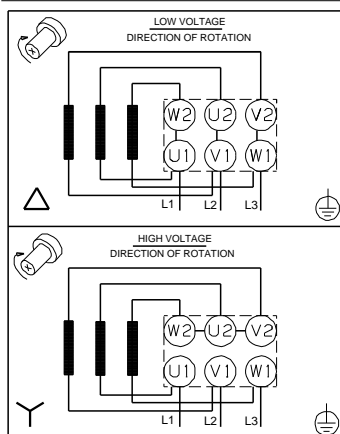
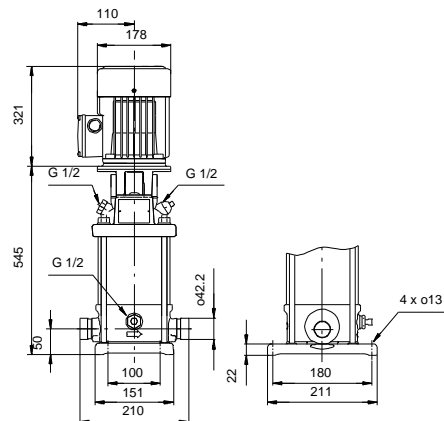
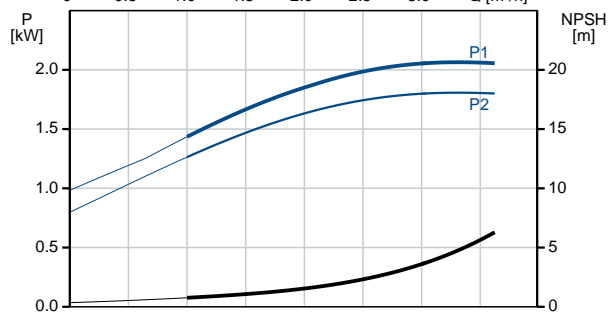
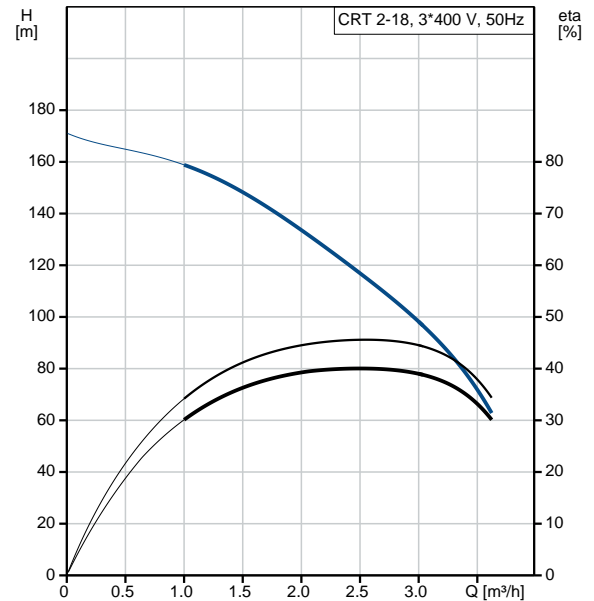



Company name:

Created by:

Phone:

Date: 19/01/2021

Description	Value
Enclosure class (IEC 34-5):	55 Dust/Jetting
Insulation class (IEC 85):	F
Motor protec:	NONE
Motor No:	85U01908
Others:	
Minimum efficiency index, MEI %:	0.7
Net weight:	36.9 kg
Gross weight:	41.9 kg

96100311 CRT 2-18 A-P-A-E-AUUE 50 Hz

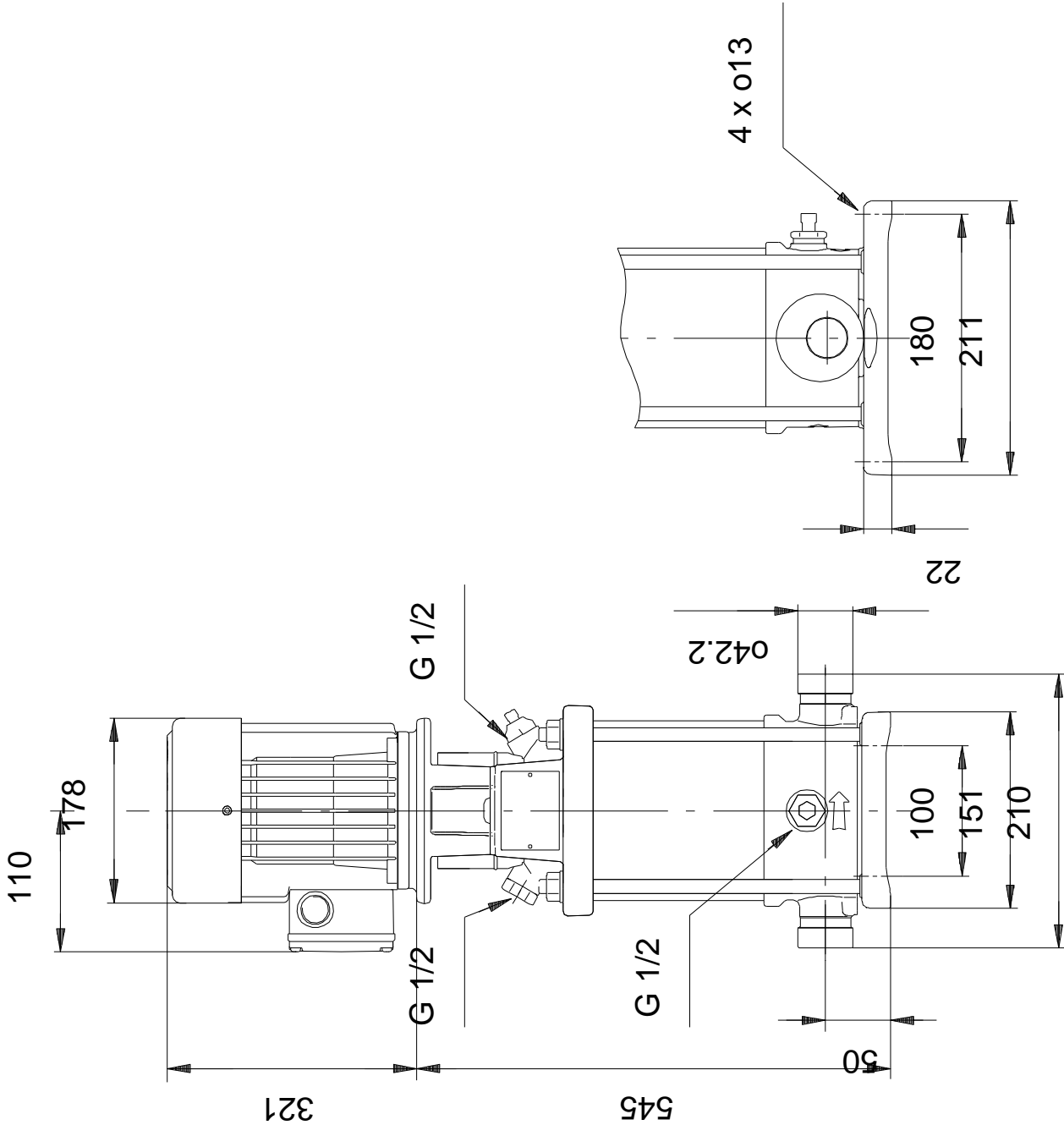

Note! All units are in [mm] unless others are stated.
Disclaimer: This simplified dimensional drawing does not show all details.

96100311 CRT 2-18 A-P-A-E-AUUE 50 Hz



Note! All units are in [mm] unless others are stated.