

Qty.	Description
1	<p data-bbox="199 336 478 369">CRT 2-7 A-P-A-E-AUUE</p>  <p data-bbox="199 660 726 772">Product No.: 96100306 Vertical, non-self-priming, multistage, in-line, centrifugal pump for installation in pipe systems and mounting on a foundation.</p> <p data-bbox="199 806 678 840">The pump has the following characteristics:</p> <ul data-bbox="231 840 758 869" style="list-style-type: none"> - Impellers, intermediate chambers and outer <p data-bbox="199 869 885 898">Impeller: sleeve are made of Titanium.</p> <p data-bbox="199 898 1133 927">Pump housing: - Pump head cover and base are made of Titanium.</p> <ul data-bbox="231 927 670 956" style="list-style-type: none"> - The shaft seal has assembly length <p data-bbox="199 956 462 985">according to EN 12756.</p> <ul data-bbox="231 985 710 1048" style="list-style-type: none"> - Power transmission is via cast iron split coupling. <p data-bbox="199 1048 925 1111">Flange standard: - Pipework connection is via PJE flanges/couplings.</p> <p data-bbox="199 1133 941 1162">Phase: The motor is a 3-phase AC motor.</p> <p data-bbox="199 1196 279 1225">Liquid:</p> <p data-bbox="199 1225 630 1254">Pumped liquid: Water</p> <p data-bbox="199 1254 710 1283">Liquid temperature range: -20 .. 120 °C</p> <p data-bbox="199 1283 630 1312">Selected liquid temperature: 20 °C</p> <p data-bbox="199 1312 702 1341">Density: 998.2 kg/m³</p> <p data-bbox="199 1375 319 1404">Technical:</p> <p data-bbox="199 1404 821 1433">Pump speed on which pump data are based: 2900 rpm</p> <p data-bbox="199 1433 662 1462">Rated flow: 2.5 m³/h</p> <p data-bbox="199 1462 622 1491">Rated head: 40 m</p> <p data-bbox="199 1491 630 1520">Primary shaft seal: AUUE</p> <p data-bbox="199 1520 638 1550">Approvals on nameplate: CE,TR</p> <p data-bbox="199 1550 766 1579">Curve tolerance: ISO9906:2012 3B</p> <p data-bbox="199 1612 311 1641">Materials:</p> <p data-bbox="199 1641 710 1704">Pump housing: Titanium ASTM B 265</p> <p data-bbox="199 1704 710 1767">Impeller: Titanium ASTM B 265</p> <p data-bbox="199 1767 638 1796">Bush material: NONE</p> <p data-bbox="199 1830 327 1859">Installation:</p> <p data-bbox="199 1859 630 1888">Maximum ambient temperature: 60 °C</p> <p data-bbox="199 1888 734 1946">Max pressure at stated temp: 25 bar / 120 °C 25 bar / -20 °C</p> <p data-bbox="199 1946 614 1975">Flange standard: PJE</p> <p data-bbox="199 1975 662 2004">Pipe connection: 42,4 mm</p> <p data-bbox="199 2004 638 2033">Flange size for motor: FT100</p> <p data-bbox="199 2067 367 2096">Electrical data:</p>

Qty.	Description
	<p>Motor type: 80A</p> <p>IE Efficiency class: IE3</p> <p>Rated power - P2: 0.75 kW</p> <p>Power (P2) required by pump: 0.75 kW</p> <p>Mains frequency: 50 Hz</p> <p>Rated voltage: 3 x 220-240D/380-415Y V</p> <p>Rated current: 3.30/1.90 A</p> <p>Starting current: 580-620 %</p> <p>Cos phi - power factor: 0.81-0.71</p> <p>Rated speed: 2840-2870 rpm</p> <p>Efficiency: IE3 80,7%</p> <p>Motor efficiency at full load: 80.7 %</p> <p>Motor efficiency at 3/4 load: 82.7 %</p> <p>Motor efficiency at 1/2 load: 81.7 %</p> <p>Number of poles: 2</p> <p>Enclosure class (IEC 34-5): 55 Dust/Jetting</p> <p>Insulation class (IEC 85): F</p> <p>Motor No: 85U05104</p> <p>Others:</p> <p>Minimum efficiency index, MEI $\hat{\alpha}\%$: 0.7</p> <p>Net weight: 19.4 kg</p> <p>Gross weight: 24.4 kg</p>

96100306 CRT 2-7 A-P-A-E-AUUE 50 Hz

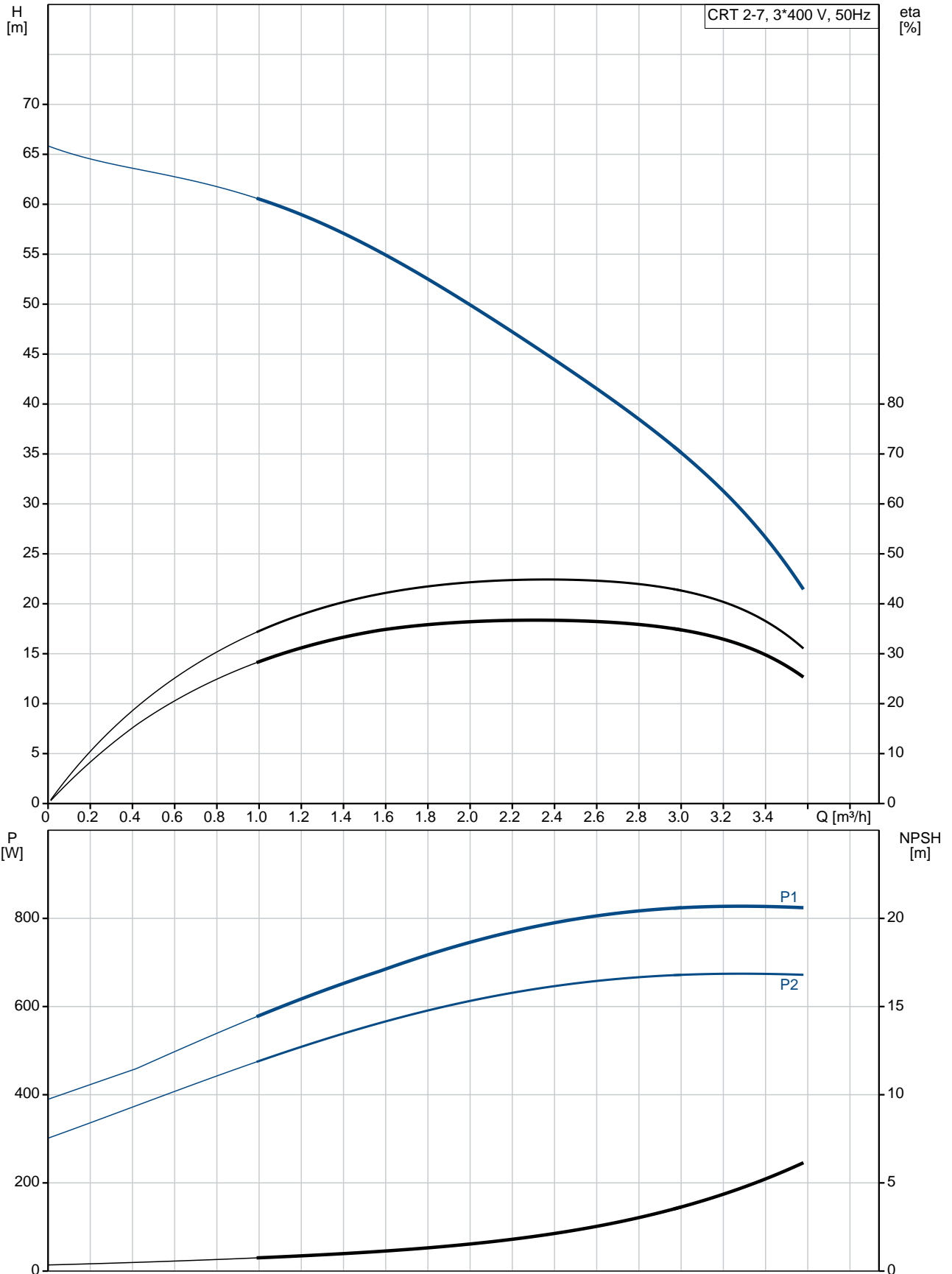

Description	Value
General information:	
Product name:	CRT 2-7 A-P-A-E-AUUE
Product No:	96100306
EAN number:	5700395842647
Price:	
Technical:	
Pump speed on which pump data are based:	2900 rpm
Rated flow:	2.5 m ³ /h
Rated head:	40 m
Maximum head:	65.1 m
Head max:	65.1 m
Stages:	7
Impellers:	7
Primary shaft seal:	AUUE
Approvals on nameplate:	CE, TR
Curve tolerance:	ISO9906:2012 3B
Pump version:	A
Model:	A
Materials:	
Pump housing:	Titanium
Pump housing:	ASTM B 265
Impeller:	Titanium
Impeller:	ASTM B 265
Material code:	A
Code for rubber:	E
Bush material:	NONE
Installation:	
Maximum ambient temperature:	60 °C
Max pressure at stated temp:	25 bar / 120 °C
Max pressure at stated temp:	25 bar / -20 °C
Flange standard:	PJE
Pipe connection:	42,4 mm
Flange size for motor:	FT100
Connect code:	P
Liquid:	
Pumped liquid:	Water
Liquid temperature range:	-20 .. 120 °C
Selected liquid temperature:	20 °C
Density:	998.2 kg/m ³
Electrical data:	
Motor type:	80A
IE Efficiency class:	IE3
Rated power - P2:	0.75 kW
Power (P2) required by pump:	0.75 kW
Power (P2) required by pump:	0.75 kW
Mains frequency:	50 Hz
Rated voltage:	3 x 220-240D/380-415Y V
Rated current:	3.30/1.90 A
Starting current:	580-620 %
Cos phi - power factor:	0.81-0.71
Rated speed:	2840-2870 rpm
Efficiency:	IE3 80,7%
Motor efficiency at full load:	80.7 %
Motor efficiency at 3/4 load:	82.7 %
Motor efficiency at 1/2 load:	81.7 %
Number of poles:	2

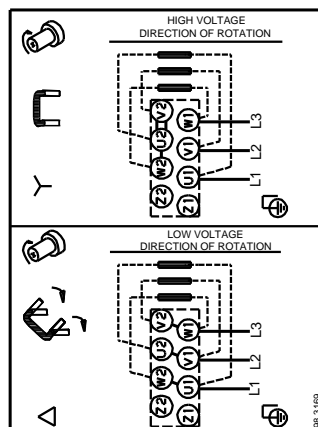
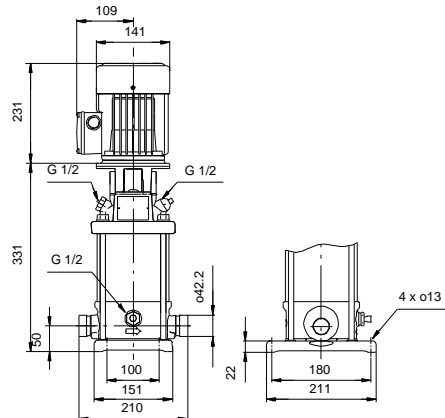
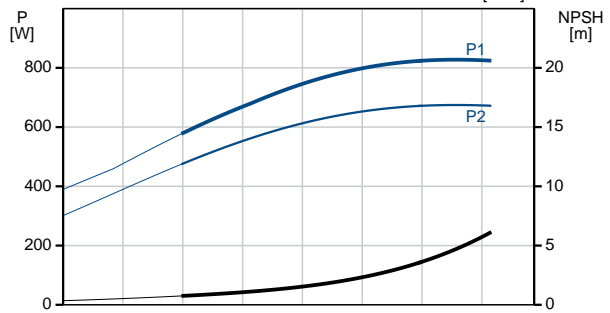
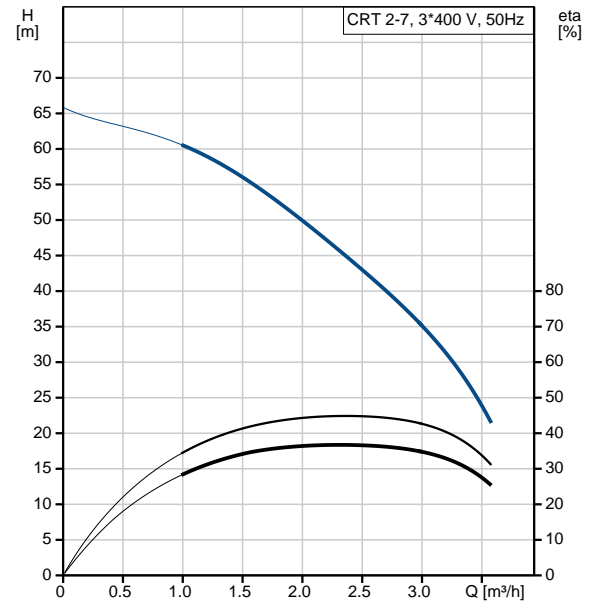



Company name:

Created by:

Phone:

Date:

19/01/2021

Description	Value
Enclosure class (IEC 34-5):	55 Dust/Jetting
Insulation class (IEC 85):	F
Motor protec:	NONE
Motor No:	85U05104
Others:	
Minimum efficiency index, MEI %:	0.7
Net weight:	19.4 kg
Gross weight:	24.4 kg

96100306 CRT 2-7 A-P-A-E-AUUE 50 Hz

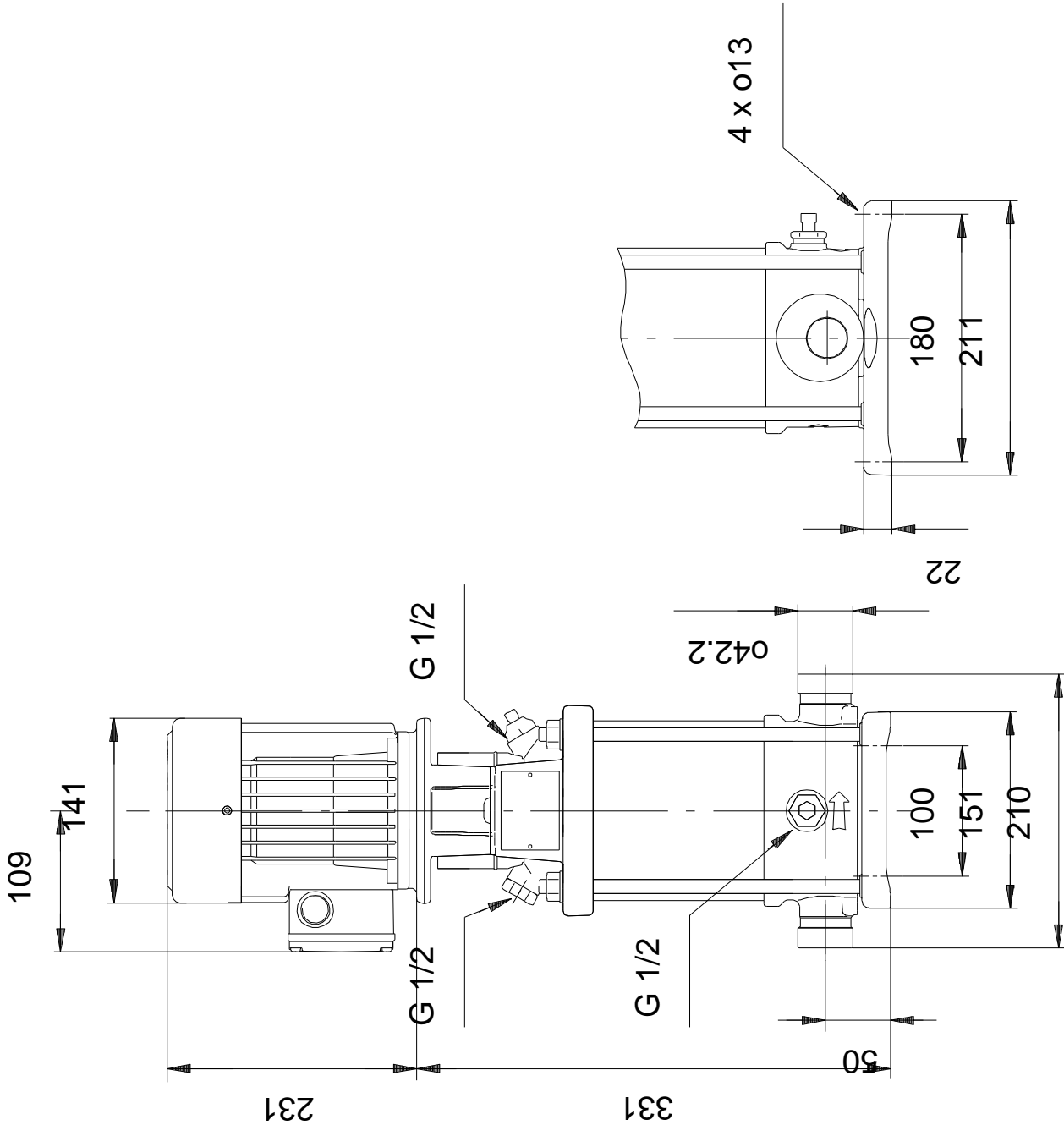

Note! All units are in [mm] unless others are stated.
Disclaimer: This simplified dimensional drawing does not show all details.

96100306 CRT 2-7 A-P-A-E-AUUE 50 Hz

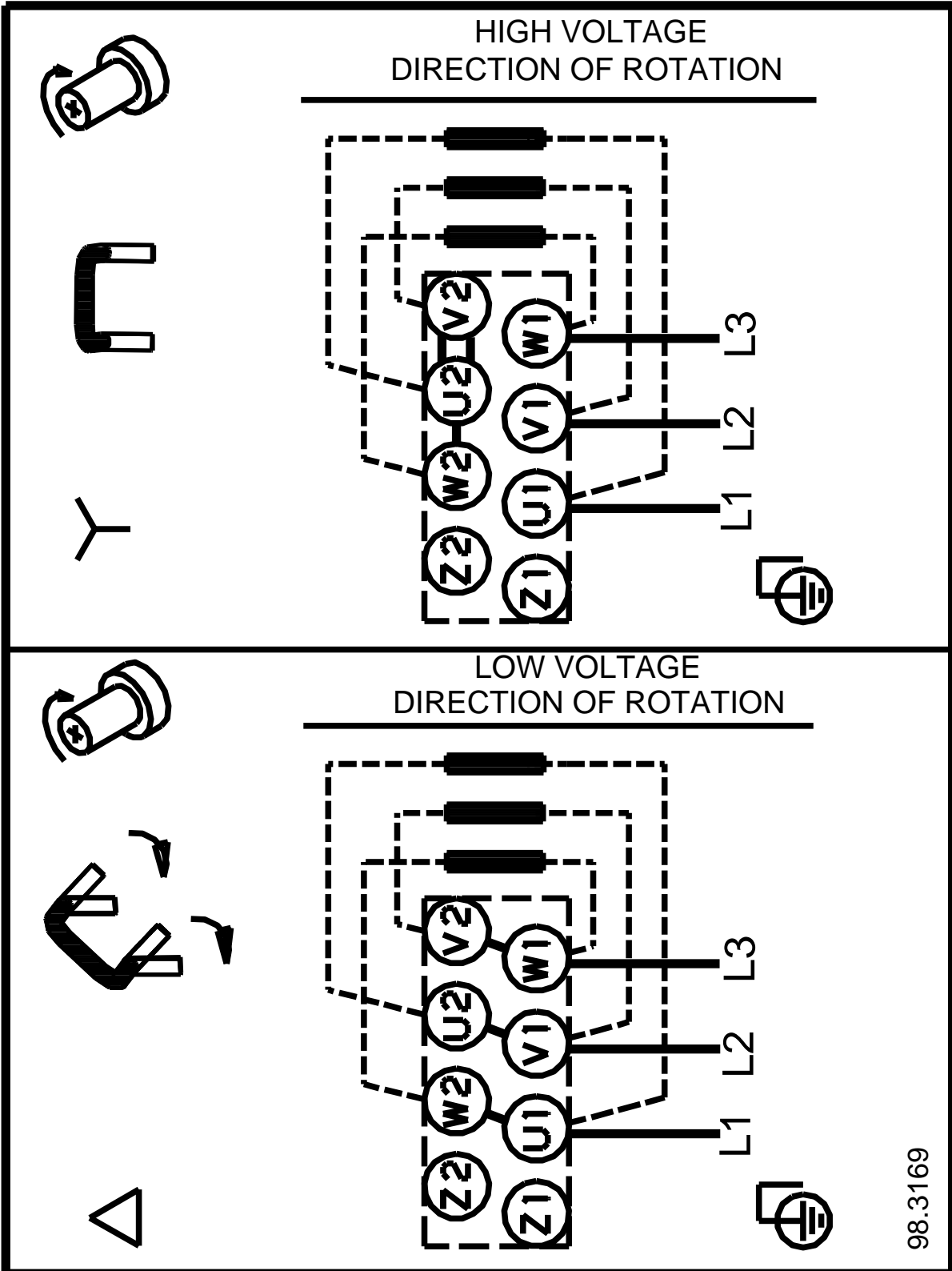

98.3169

Note! All units are in [mm] unless others are stated.