

Qty.	Description
1	<p data-bbox="199 338 478 369">CRT 2-7 A-P-A-E-AUUE</p> <div data-bbox="347 387 443 629" style="text-align: center;">  </div> <p data-bbox="199 660 470 689">Product No.: 96100270</p> <p data-bbox="199 689 726 779">Vertical, non-self-priming, multistage, in-line, centrifugal pump for installation in pipe systems and mounting on a foundation.</p> <p data-bbox="199 808 678 837">The pump has the following characteristics:</p> <ul style="list-style-type: none"> <li data-bbox="236 837 758 866">- Impellers, intermediate chambers and outer <p data-bbox="199 866 885 896">Impeller: sleeve are made of Titanium.</p> <p data-bbox="199 896 1133 925">Pump housing: - Pump head cover and base are made of Titanium.</p> <ul style="list-style-type: none"> <li data-bbox="236 925 670 954">- The shaft seal has assembly length <p data-bbox="199 954 462 983">according to EN 12756.</p> <ul style="list-style-type: none"> <li data-bbox="236 983 710 1048">- Power transmission is via cast iron split coupling. <p data-bbox="199 1048 925 1113">Flange standard: - Pipework connection is via PJE flanges/couplings.</p> <p data-bbox="199 1135 941 1164">Phase: The motor is a 1-phase AC motor.</p> <p data-bbox="199 1193 279 1223">Liquid:</p> <p data-bbox="199 1223 630 1252">Pumped liquid: Water</p> <p data-bbox="199 1252 710 1281">Liquid temperature range: -20 .. 120 °C</p> <p data-bbox="199 1281 630 1310">Selected liquid temperature: 20 °C</p> <p data-bbox="199 1310 702 1339">Density: 998.2 kg/m³</p> <p data-bbox="199 1370 319 1400">Technical:</p> <p data-bbox="199 1400 821 1429">Pump speed on which pump data are based: 2900 rpm</p> <p data-bbox="199 1429 662 1458">Rated flow: 2.5 m³/h</p> <p data-bbox="199 1458 646 1487">Rated head: 43.3 m</p> <p data-bbox="199 1487 630 1516">Primary shaft seal: AUUE</p> <p data-bbox="199 1516 646 1545">Approvals on nameplate: CE,TR</p> <p data-bbox="199 1545 766 1574">Curve tolerance: ISO9906:2012 3B</p> <p data-bbox="199 1606 311 1635">Materials:</p> <p data-bbox="199 1635 710 1700">Pump housing: Titanium ASTM B 265</p> <p data-bbox="199 1700 710 1765">Impeller: Titanium ASTM B 265</p> <p data-bbox="199 1765 638 1794">Bush material: NONE</p> <p data-bbox="199 1825 327 1854">Installation:</p> <p data-bbox="199 1854 630 1883">Maximum ambient temperature: 40 °C</p> <p data-bbox="199 1883 734 1946">Max pressure at stated temp: 25 bar / 120 °C 25 bar / -20 °C</p> <p data-bbox="199 1946 614 1975">Flange standard: PJE</p> <p data-bbox="199 1975 662 2004">Pipe connection: 42,4 mm</p> <p data-bbox="199 2004 638 2033">Flange size for motor: FT100</p> <p data-bbox="199 2065 367 2094">Electrical data:</p>



Company name:

Created by:

Phone:

Date:

19/01/2021

Qty. Description

Motor type: 80B
Rated power - P2: 0.75 kW
Power (P2) required by pump: 0.75 kW
0.75 kW
Mains frequency: 50 Hz
Rated voltage: 1 x 220-230/240 V
Rated current: 5.10/4.75 A
Starting current: 300 %
Cos phi - power factor: 0.99
Rated speed: 2780 rpm
Efficiency: 72.1%
Motor efficiency at full load: 72.1 %
Number of poles: 2
Enclosure class (IEC 34-5): 55 Dust/Jetting
Insulation class (IEC 85): F
Motor No: 85215104

Others:
Minimum efficiency index, MEI η_{min} : 0.7
Net weight: 19.4 kg
Gross weight: 24.4 kg

96100270 CRT 2-7 A-P-A-E-AUUE 50 Hz

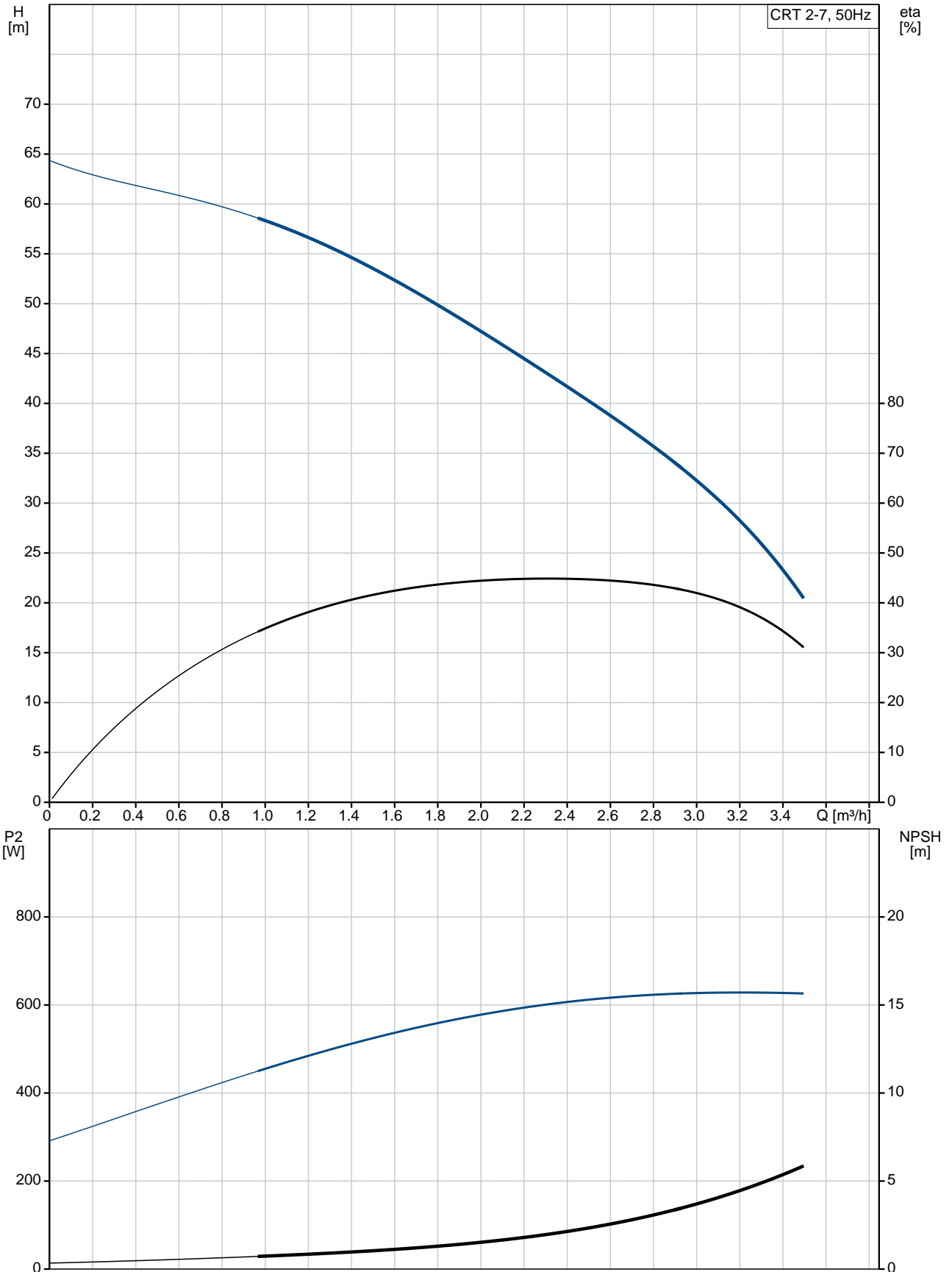

Description	Value
General information:	
Product name:	CRT 2-7 A-P-A-E-AUUE
Product No:	96100270
EAN number:	5700395841480
Price:	
Technical:	
Pump speed on which pump data are based:	2900 rpm
Rated flow:	2.5 m ³ /h
Rated head:	43.3 m
Maximum head:	65.1 m
Head max:	65.1 m
Stages:	7
Impellers:	7
Primary shaft seal:	AUUE
Approvals on nameplate:	CE,TR
Curve tolerance:	ISO9906:2012 3B
Pump version:	A
Model:	A
Materials:	
Pump housing:	Titanium
Pump housing:	ASTM B 265
Impeller:	Titanium
Impeller:	ASTM B 265
Material code:	A
Code for rubber:	E
Bush material:	NONE
Installation:	
Maximum ambient temperature:	40 °C
Max pressure at stated temp:	25 bar / 120 °C
Max pressure at stated temp:	25 bar / -20 °C
Flange standard:	PJE
Pipe connection:	42,4 mm
Flange size for motor:	FT100
Connect code:	P
Liquid:	
Pumped liquid:	Water
Liquid temperature range:	-20 .. 120 °C
Selected liquid temperature:	20 °C
Density:	998.2 kg/m ³
Electrical data:	
Motor type:	80B
Rated power - P2:	0.75 kW
Power (P2) required by pump:	0.75 kW
Power (P2) required by pump:	0.75 kW
Mains frequency:	50 Hz
Rated voltage:	1 x 220-230/240 V
Rated current:	5.10/4.75 A
Starting current:	300 %
Cos phi - power factor:	0.99
Rated speed:	2780 rpm
Efficiency:	72.1%
Motor efficiency at full load:	72.1 %
Number of poles:	2
Enclosure class (IEC 34-5):	55 Dust/Jetting
Insulation class (IEC 85):	F
Motor protec:	PTO
Motor No:	85215104

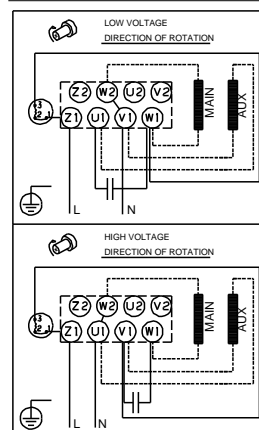
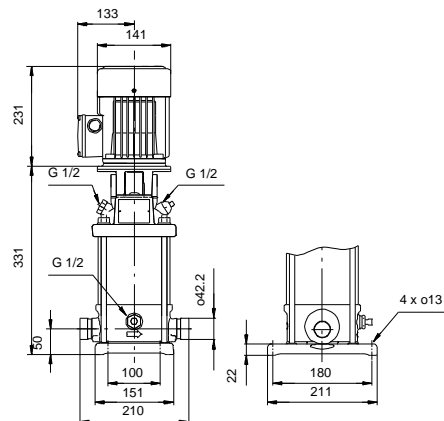
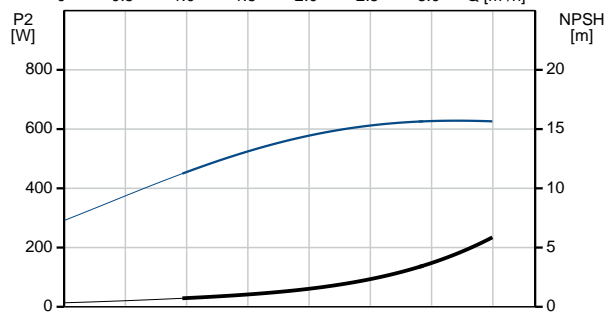
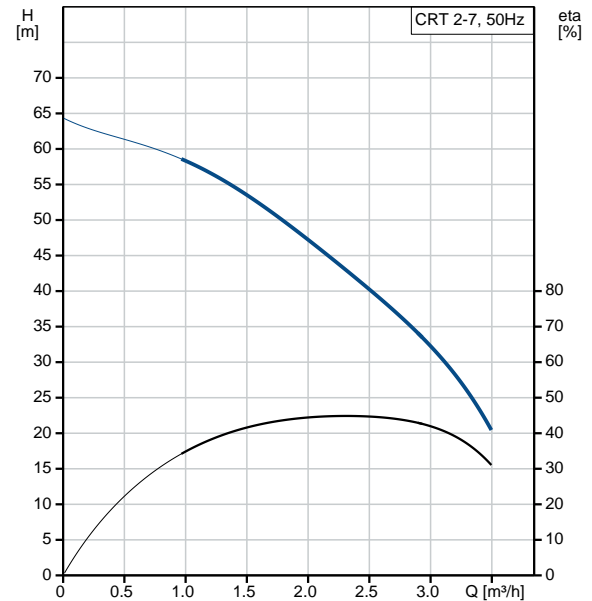



Company name:

Created by:

Phone:

Date:

19/01/2021

Description	Value
Others:	
Minimum efficiency index, MEI %:	0.7
Net weight:	19.4 kg
Gross weight:	24.4 kg

96100270 CRT 2-7 A-P-A-E-AUUE 50 Hz

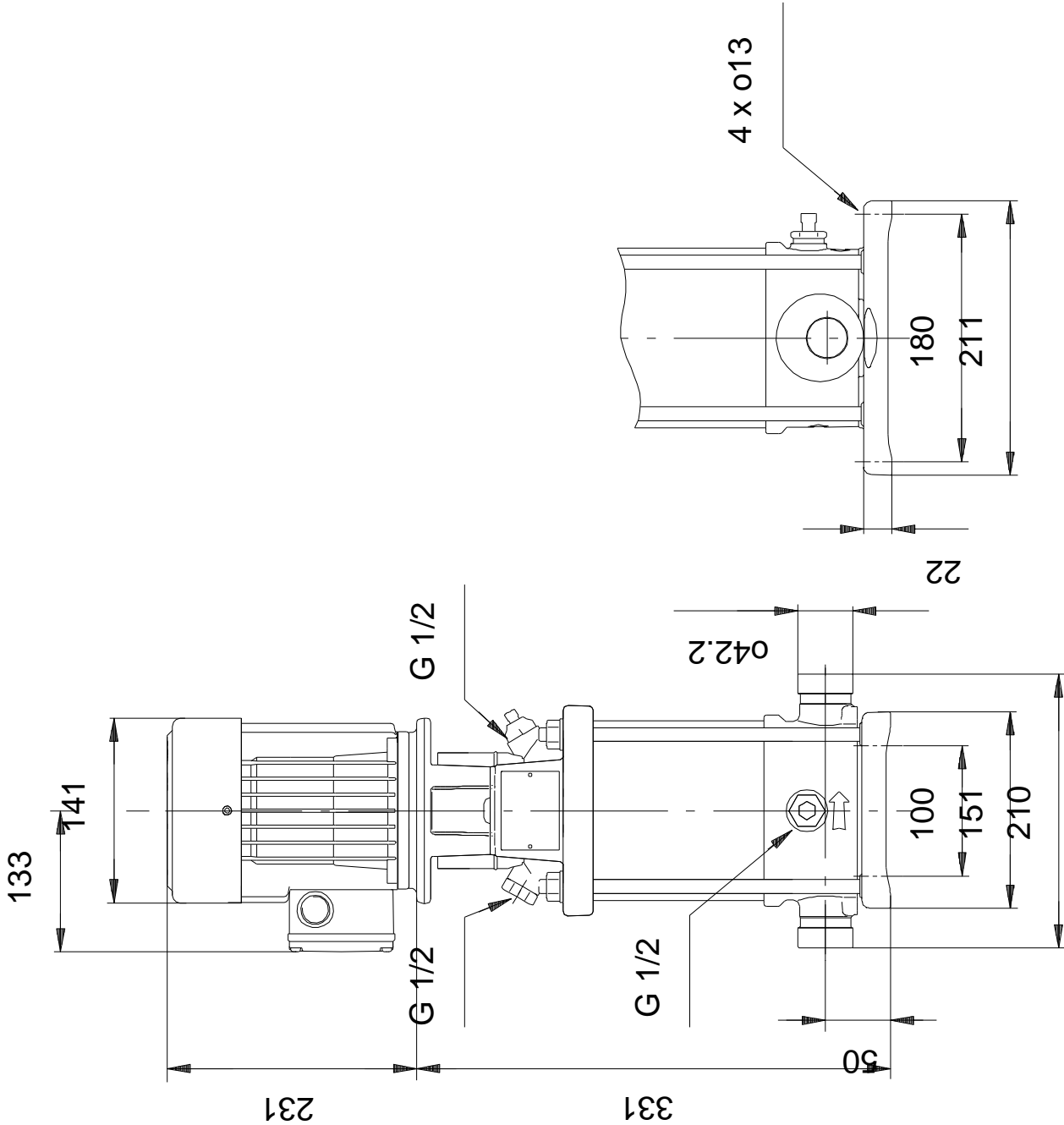

Note! All units are in [mm] unless others are stated.
Disclaimer: This simplified dimensional drawing does not show all details.

96100270 CRT 2-7 A-P-A-E-AUUE 50 Hz

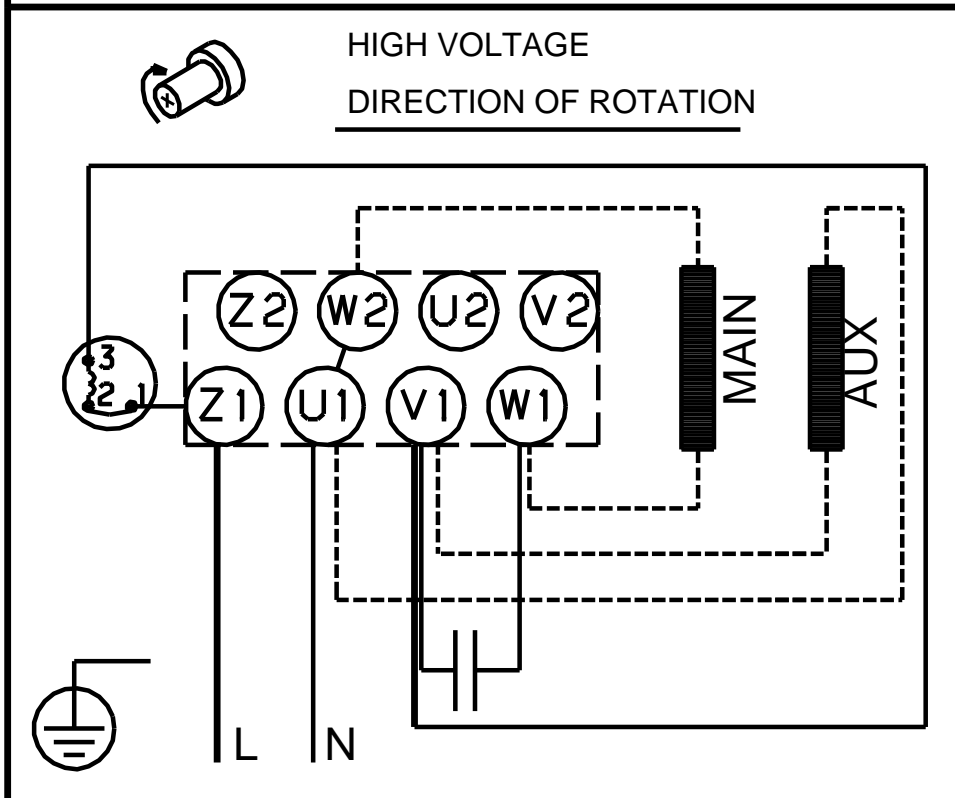
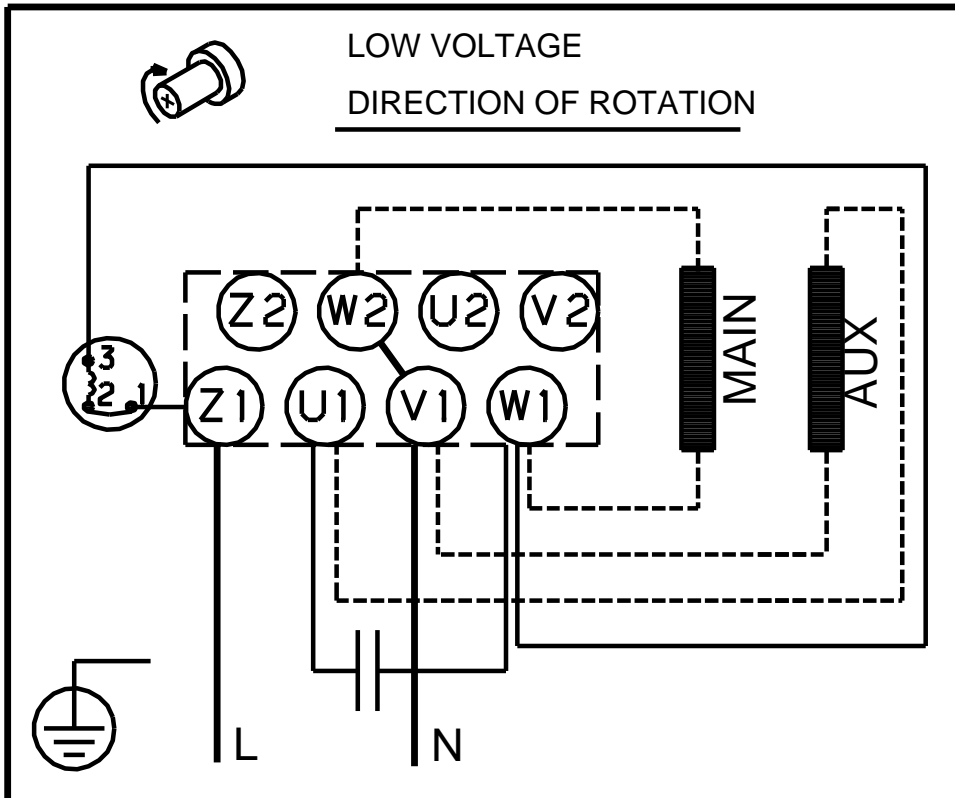

Note! All units are in [mm] unless others are stated.