

Position	Qty.	Description
	1	<p>TPD 65-110/4 A-F-A-BQQE</p>  <p>Product No.: 96087478</p> <p>Single-stage, close-coupled, volute twin-head pump with in-line suction and discharge ports of identical diameter. The twin-head pump is designed with two parallel power-heads. The pump is of the top-pull-out design, i.e. the power head (motor, pump head and impeller) can be removed for maintenance or service while the pump housing remains in the pipework.</p> <p>Each power head is fitted with an unbalanced rubber bellows seal. The shaft seal is according to EN 12756. Pipework connection is via PN 16 DIN flanges (EN 1092-2 and ISO 7005-2).</p> <p>Each power head is fitted with a fan-cooled asynchronous motor of identical size.</p> <p>Liquid:</p> <p>Pumped liquid: Water Liquid temperature range: -25 .. 120 °C Liquid temperature during operation: 20 °C Density: 998.2 kg/m³</p> <p>Technical:</p> <p>Rated flow: 32.4 m³/h Rated head: 7.9 m Actual impeller diameter: 180 mm Primary shaft seal: BQQE Curve tolerance: ISO9906:2012 3B</p> <p>Materials:</p> <p>Pump housing: Cast iron EN-JL1040 ASTM A48-40 B</p> <p>Impeller: Cast iron EN-JL1030 ASTM A48-30 B</p> <p>Installation:</p> <p>Range of ambient temperature: -30 .. 60 °C Maximum operating pressure: 16 bar Flange standard: DIN Pipe connection: DN 65 Pump inlet: DN 65 Pump outlet: DN 65 Pressure rating: PN 16 (@): 475 mm Flange size for motor: FF165</p> <p>Electrical data:</p> <p>Motor type: 90SB IE Efficiency class: IE3 Rated power - P2: 2 x 1.1 kW Power (P2) required by pump: 1.1 kW Mains frequency: 50 Hz</p>

Position	Qty.	Description
		<p>Rated voltage: 3 x 220-240D/380-415Y V</p> <p>Rated current: 4.85/2.80 A</p> <p>Starting current: 820-900 %</p> <p>Cos phi - power factor: 0.71-0.64</p> <p>Rated speed: 1450-1460 rpm</p> <p>Efficiency: IE3 84,1%</p> <p>Motor efficiency at full load: 84.1 %</p> <p>Motor efficiency at 3/4 load: 84.6 %</p> <p>Motor efficiency at 1/2 load: 82.9 %</p> <p>Number of poles: 4</p> <p>Enclosure class (IEC 34-5): 55 Dust/Jetting</p> <p>Insulation class (IEC 85): F</p> <p>Others:</p> <p>Minimum efficiency index, MEI : 0.70</p> <p>ErP status: EuP Standalone/Prod.</p> <p>Net weight: 150 kg</p> <p>Gross weight: 170 kg</p> <p>Shipping volume: 0.52 m³</p>

96087478 TPD 65-110/4 A-F-A-BQQE 50 Hz

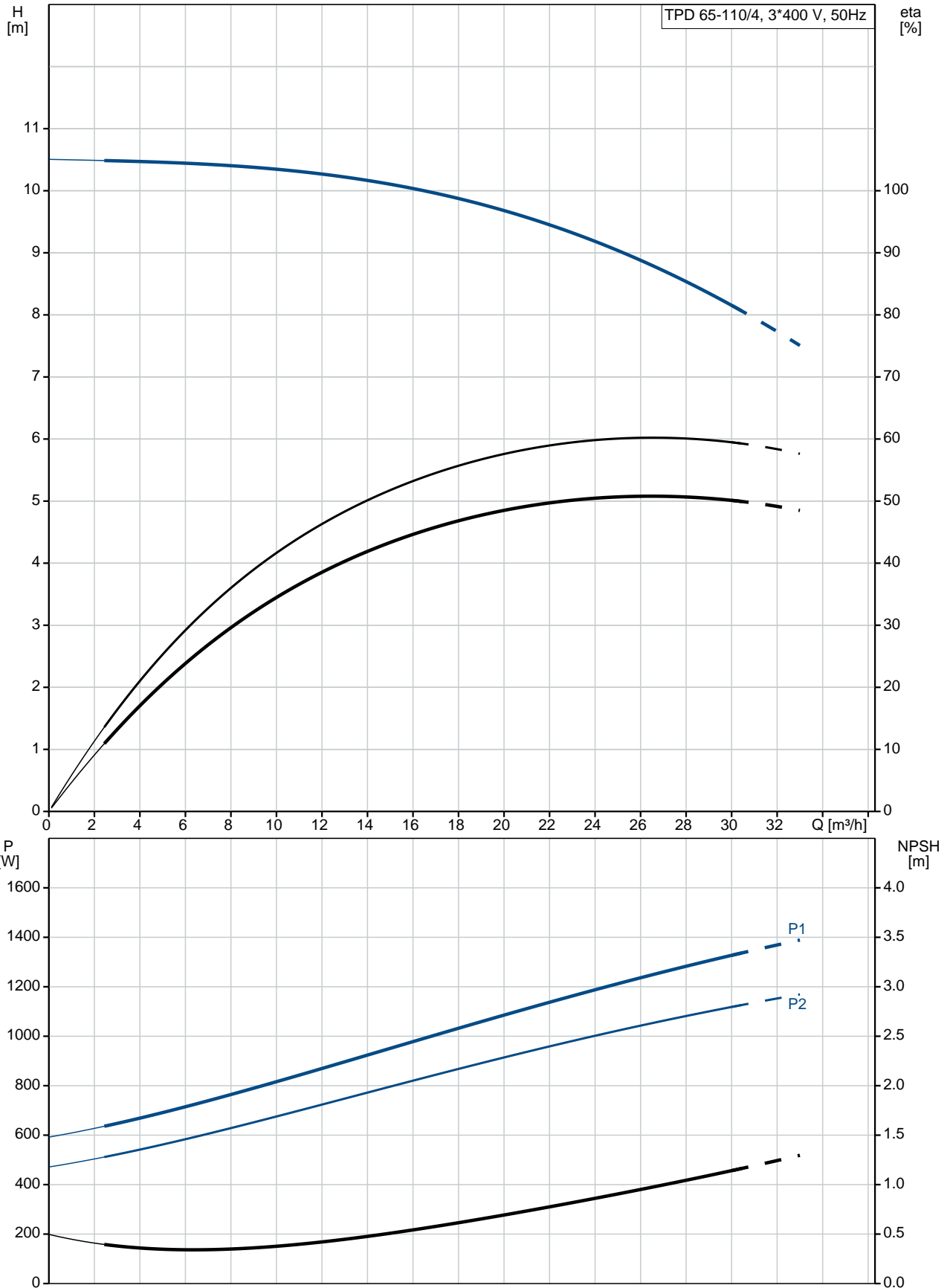

Description	Value
General information:	
Product name:	TPD 65-110/4 A-F-A-BQQE
Product No:	96087478
EAN number:	5700395314441
Technical:	
Rated flow:	32.4 m ³ /h
Rated head:	7.9 m
Head max:	110 dm
Actual impeller diameter:	180 mm
Primary shaft seal:	BQQE
Curve tolerance:	ISO9906:2012 3B
Pump version:	A
Model:	A
Materials:	
Pump housing:	Cast iron EN-JL1040 ASTM A48-40 B
Impeller:	Cast iron EN-JL1030 ASTM A48-30 B
Material code:	A
Installation:	
Range of ambient temperature:	-30 .. 60 °C
Maximum operating pressure:	16 bar
Flange standard:	DIN
Pipe connection:	DN 65
Pump inlet:	DN 65
Pump outlet:	DN 65
Pressure rating:	PN 16
(@)	475 mm
Flange size for motor:	FF165
Connect code:	F
Liquid:	
Pumped liquid:	Water
Liquid temperature range:	-25 .. 120 °C
Liquid temperature during operation:	20 °C
Density:	998.2 kg/m ³
Electrical data:	
Motor type:	90SB
IE Efficiency class:	IE3
Rated power - P2:	2 x 1.1 kW
Power (P2) required by pump:	1.1 kW
Mains frequency:	50 Hz
Rated voltage:	3 x 220-240D/380-415Y V
Rated current:	4.85/2.80 A
Starting current:	820-900 %
Cos phi - power factor:	0.71-0.64
Rated speed:	1450-1460 rpm
Efficiency:	IE3 84,1%
Motor efficiency at full load:	84.1 %
Motor efficiency at 3/4 load:	84.6 %
Motor efficiency at 1/2 load:	82.9 %
Number of poles:	4
Enclosure class (IEC 34-5):	55 Dust/Jetting
Insulation class (IEC 85):	F
Motor protec:	NONE
Motor No:	87220316
Others:	

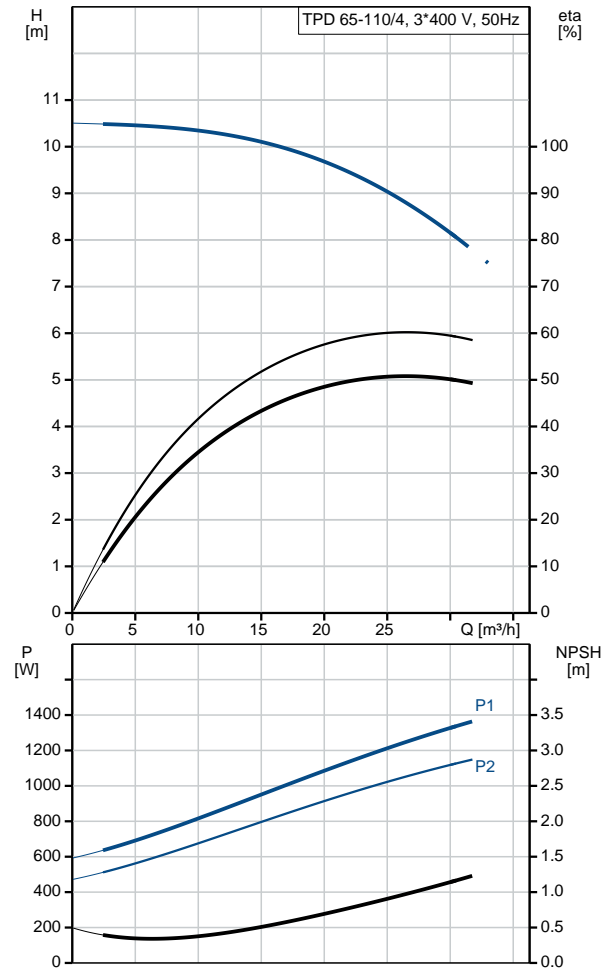



Company name:

Created by:

Phone:

Date:

05/10/2018

Description	Value
Minimum efficiency index, MEI :	0.70
ErP status:	EuP Standalone/Prod.
Net weight:	150 kg
Gross weight:	170 kg
Shipping volume:	0.52 m ³

96087478 TPD 65-110/4 A-F-A-BQQE 50 Hz

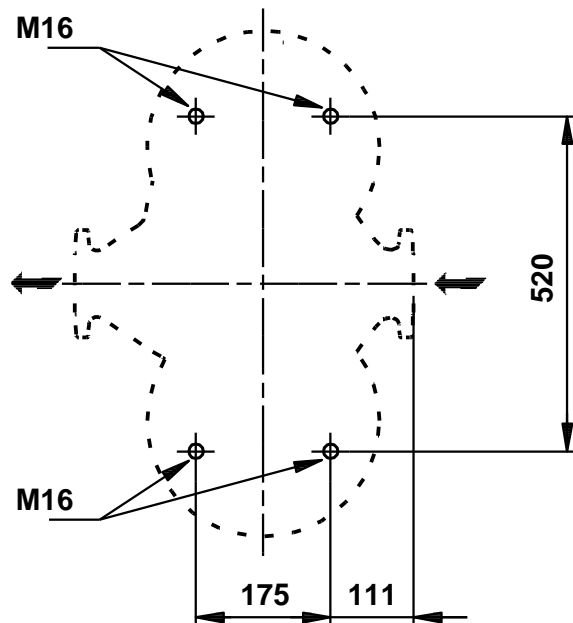
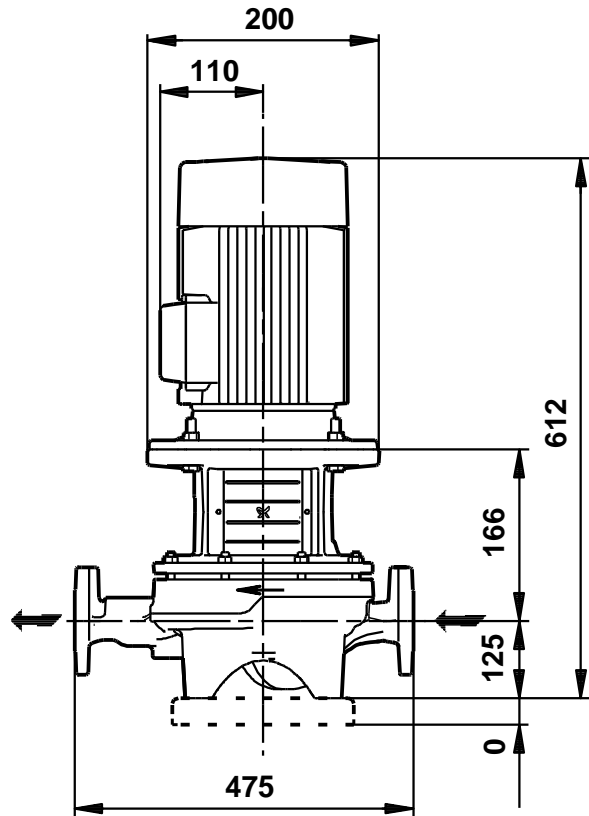
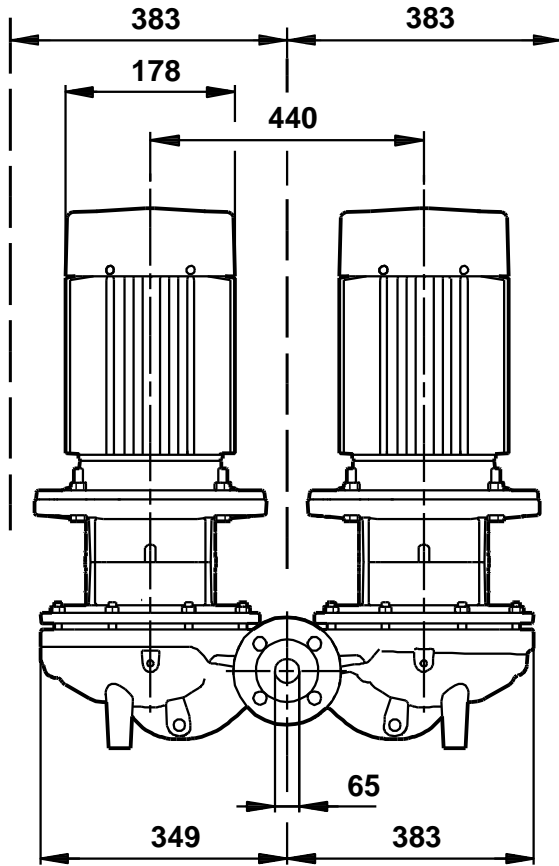

Note! All units are in [mm] unless others are stated.
Disclaimer: This simplified dimensional drawing does not show all details.

96087478 TPD 65-110/4 A-F-A-BQQE 50 Hz

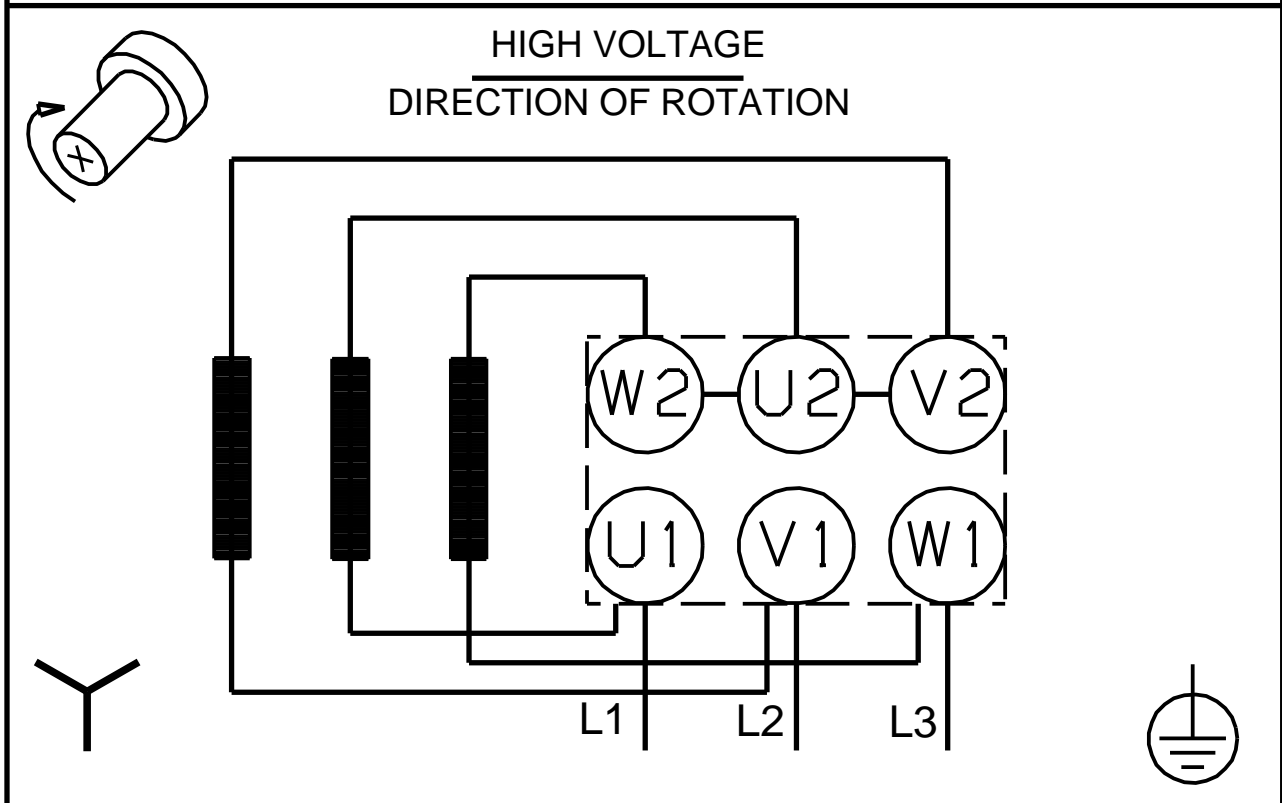
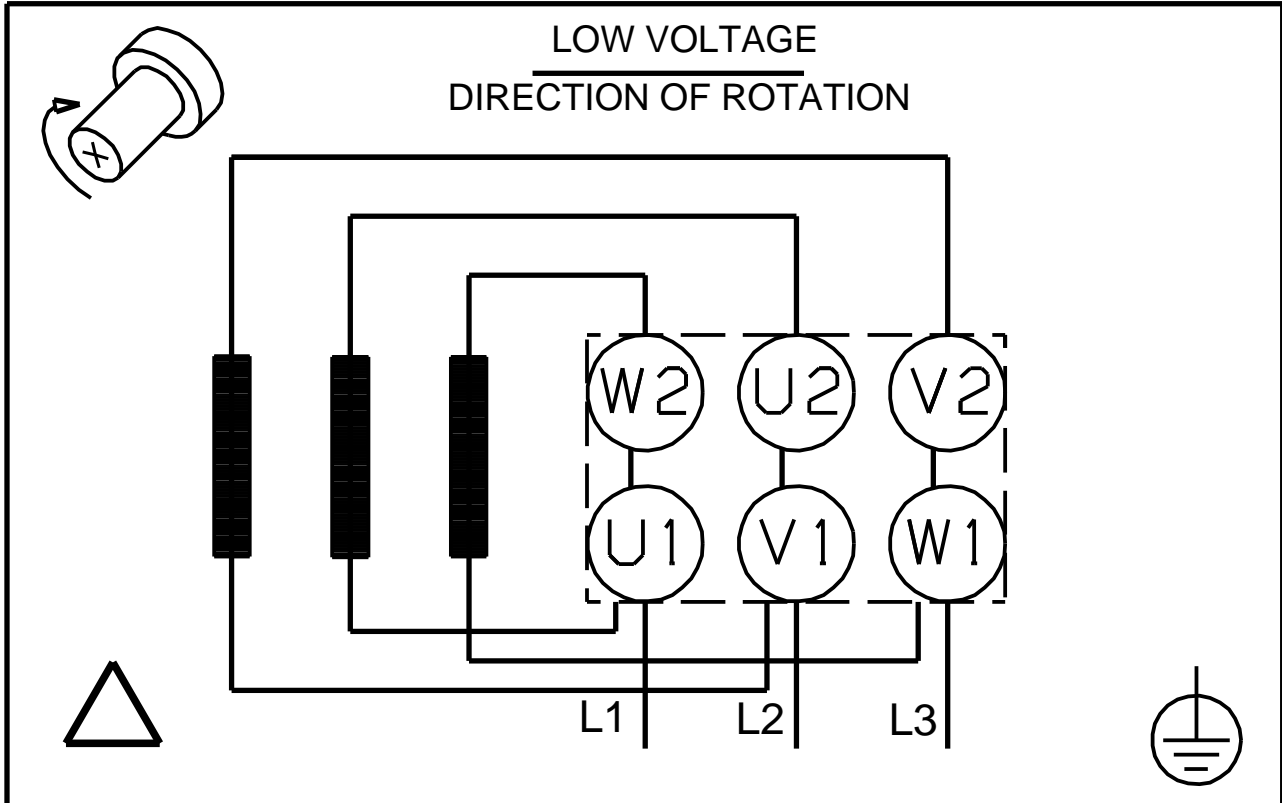

Note! All units are in [mm] unless others are stated.