

## Data sheet: Stratos GIGA B 40/1-44/4,5

### Hydraulic data

Minimum efficiency index (MEI)	0.7
Maximum operating pressure $p$	16 bar
Min. fluid temperature $T_{min}$	-20 °C
Max. fluid temperature $T_{max}$	140 °C
Min. ambient temperature $T_{min}$	0 °C
Max. ambient temperature $T_{max}$	40 °C

### Materials

Pump housing	5.1301, KTL-coated
Impeller	PPS-GF40
Shaft	1.4542
Shaft seal	AQ1EGG
Lantern	5.1301, KTL-coated

### Installation dimensions

Pipe connection on the suction side <i>DN<sub>s</sub></i>	DN 65
Pipe connection on the pressure side <i>DN<sub>d</sub></i>	DN 40

### Motor data

Mains connection	3~400 V, 50/60 Hz
Motor efficiency class	IE5
Rated power $P_2$	4.50 kW
Rated current $I_N$	9.10 A
Rated speed $n$	4930 rpm
Max. speed $n_{max}$	4930 rpm
Power consumption $P_{1 max}$	5360.0 W
Emitted interference	EN 61800-3
Interference resistance	EN 61800-3
Insulation class	F
Protection class motor	IP55
Threaded cable connection	1 x M12x1.5

### Approved liquids (other liquids upon request)

Heating water (as per VDI 2035)	yes
Heat carrier oil	Special version at additional charge
Cooling and cold water circulation systems	yes
Water-glycol mixtures (at 20 – 40 vol. % glycol and fluid temperature $\leq$ 40 °C)	yes

### Information for order placements

Brand	Wilo
Product description	Stratos GIGA B 40/1-44/4,5
EAN number	4048482778419
Article number	2189115
Net weight, approx. $m$	51 kg
Gross weight, approx. $m$	57.0 kg
Length with packaging	795 mm
Height with packaging	615 mm
Width with packaging	515 mm
Packaging property	Transport packaging
Packaging type	Cardboard box
Minimum order quantity	1

## Dimensions and dimensions drawings: Stratos GIGA B 40/1-44/4,5

Stratos GIGA B 40/1-44/4,5

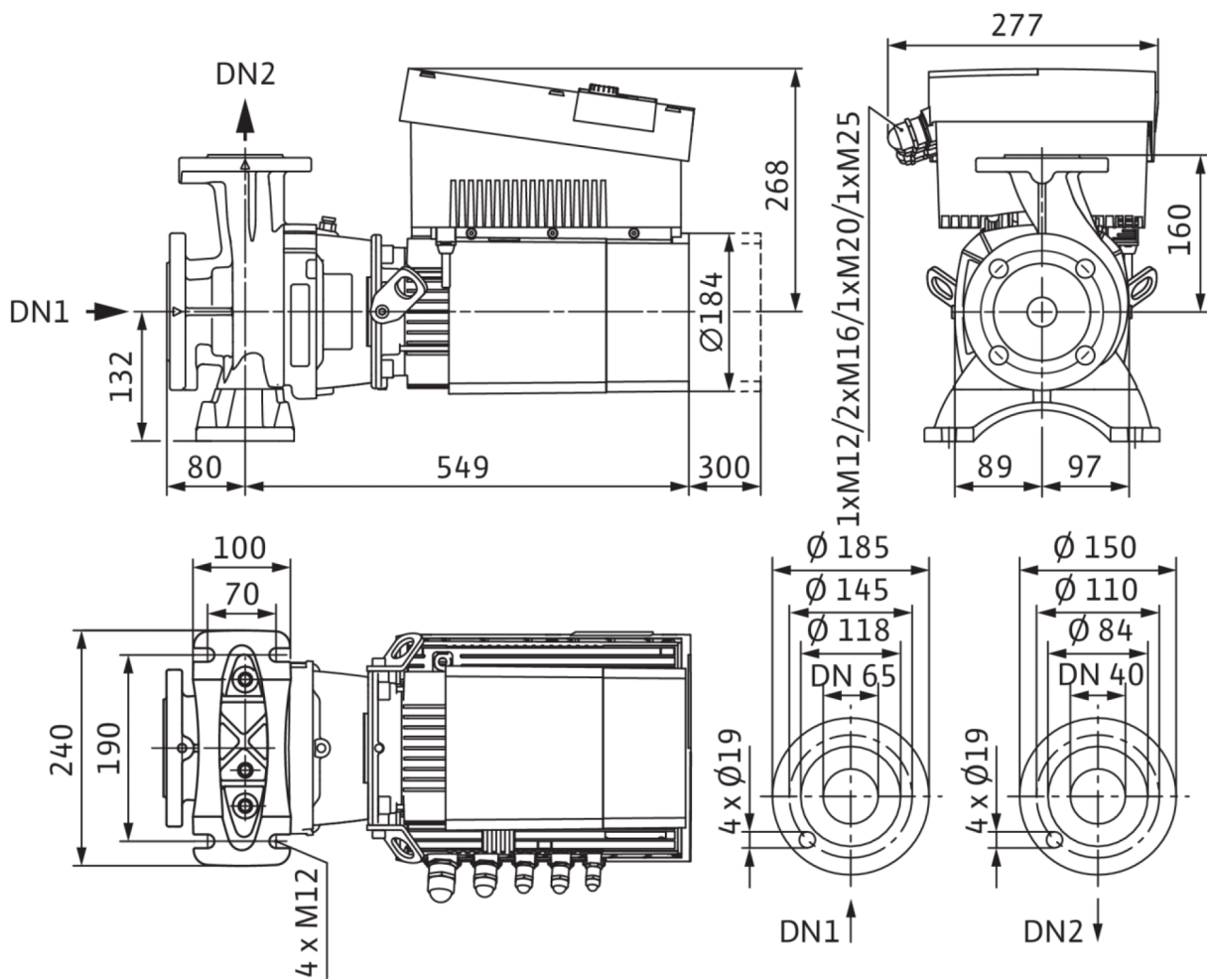

## Pump curves: Stratos GIGA B 40/1-44/4,5

Stratos GIGA B 40/1-44/4,5

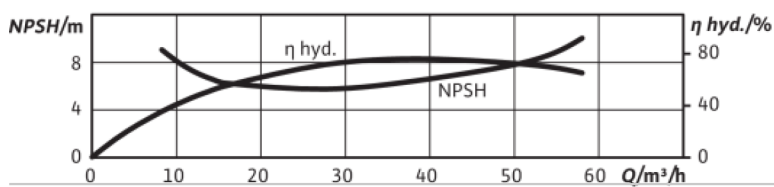
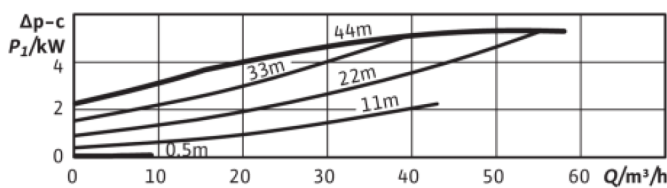
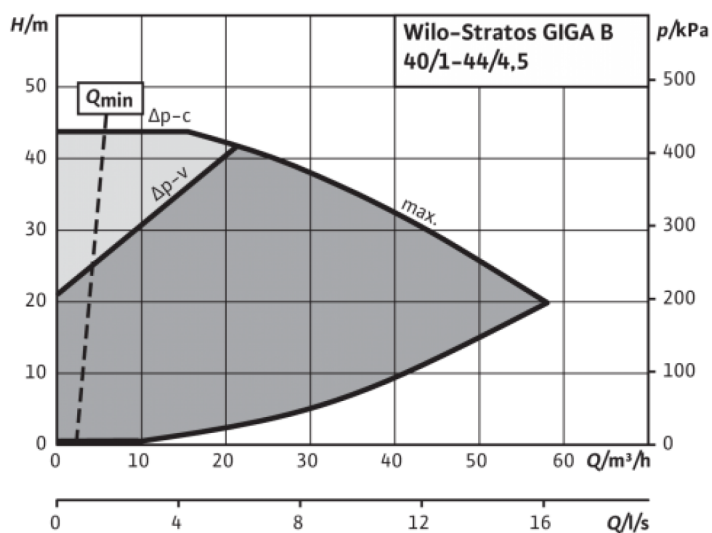
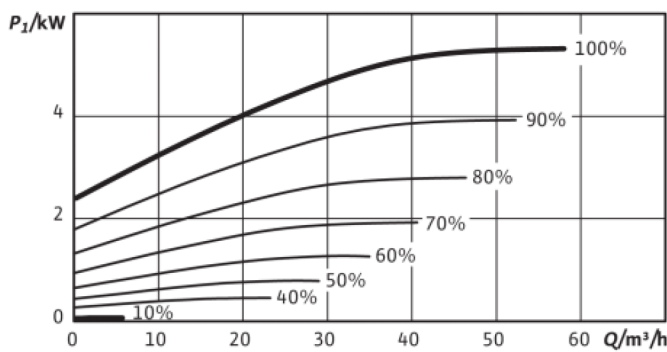
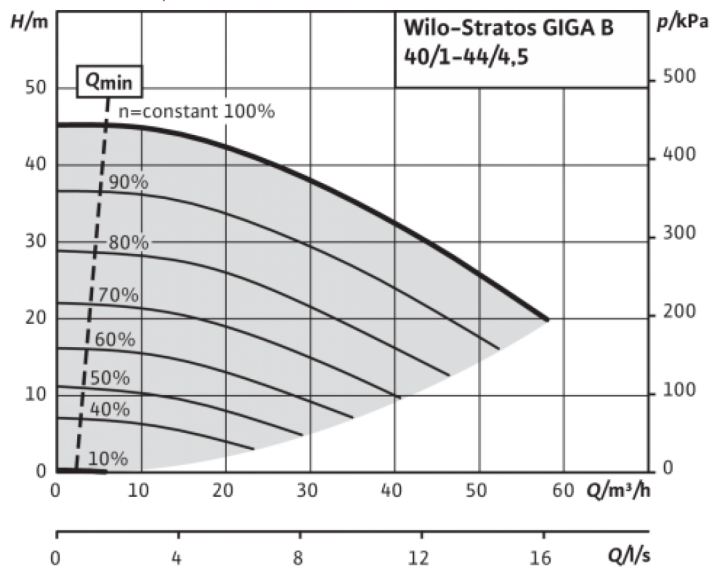

## Wiring diagram: Stratos GIGA B 40/1-44/4,5

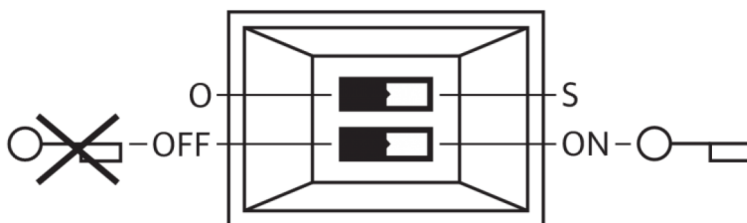
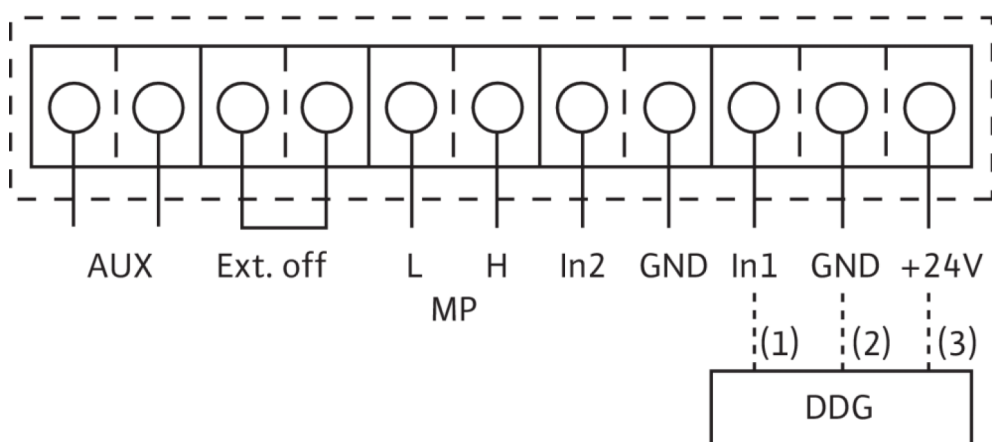
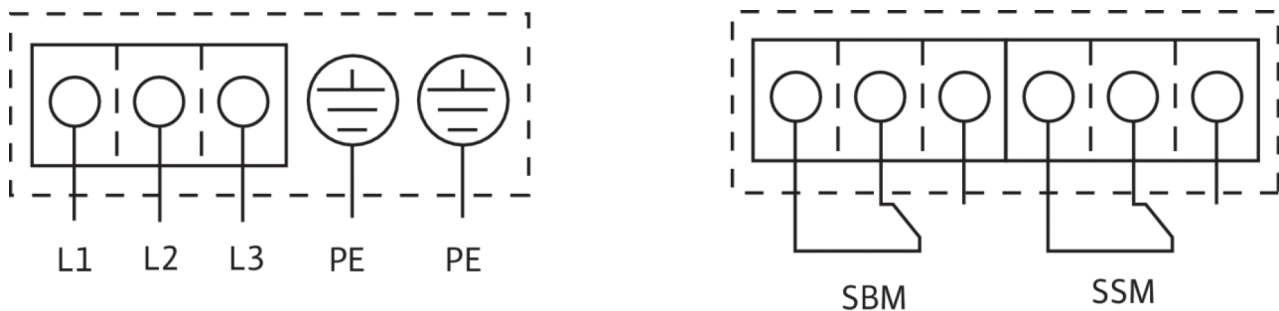

L1, L2, L3:  
PE:  
DDG:  
In1 (1):  
GND (2):  
+ 24 V (3):  
In2:  
MP:  
Ext. off:

Mains connection: 3-380 V - 3-480 V ( $\pm 10\%$ ), 50/60 Hz  
Protective conductor connection  
Connection for differential pressure sensor  
Actual value input 0 - 10 V/0 - 20 mA; 2 - 10 V/4 - 20 mA  
Ground connection for In1 and In2  
DC voltage output for an external consumer/sensor. Max load 60 mA  
Setpoint input 0 - 10 V/0 - 20 mA; 2 - 10 V/4 - 20 mA  
Multi-pump, interface for dual pump management

"Overriding Off" control input

The pump can be switched on or off via an external, potential-free contact (24 V DC/10 mA).  
Potential-free collective run signal (changeover contact according to VDI 3814)  
Potential-free collective fault signal (changeover contact according to VDI 3814)  
External pump cycling (only with double pump operation). Pump cycling can be performed using an external, potential-free contact (24 V DC/10 mA)

1: Switchover between operation (O) and service mode (S)

2: Activate/deactivate the menu for access disable  
IF-Module for connection to building automation

SBM:\*  
SSM:\*  
AUX:

DIP switch:

Optional:

\* Load capacity of contacts for SBM and SSM:

min.: 12 V DC/10 mA

max.: 250 V AC/1 A