

Hydraulic data

Maximum operating pressure <i>P_N</i>	10 bar
Min. fluid temperature for HVAC applications <i>T_{min}</i>	0 °C
Max. fluid temperature for HVAC <i>T</i>	80 °C
Min. ambient temperature <i>T_{min}</i>	0 °C
Max. ambient temperature <i>T_{max}</i>	40 °C
Max. permitted total water hardness	3.57 mmol/l (20°dH)

Materials

Pump housing	Stainless steel
Impeller	PPS-GF40
Shaft	1.4122, DLC-coated
Bearing	Carbon-graphite

Motor data

Energy efficiency index (EEI)	0.17
Mains connection	1~230 V, 50/60 Hz
Rated power <i>P₂</i>	0.46 kW
Rated current <i>I_N</i>	2.40 A
Min. speed <i>n_{min}</i>	650 1/min
Max. speed <i>n_{max}</i>	3050 1/min
Power consumption <i>P_{1 min}</i>	10.0 W
Power consumption <i>P_{1 max}</i>	550.0 W
Interference emission	EN 61800-3;2004+A1;2012 /residential area (C1)
Interference immunity	EN 61800-3;2004+A1;2012 /industrial environment (C2)
Speed control	Frequency converter
Insulation class	F
Protection class motor	IPX4D
Motor protection	Internal protection overheating and overcurrent

Installation dimensions

Pipe connection on the suction side <i>DN_s</i>	DN 50
Pipe connection on the pressure side <i>DN_d</i>	DN 50
Port-to-port length <i>L₀</i>	280 mm

Wilo-Stratos MAXO-Z 50/0,5-9

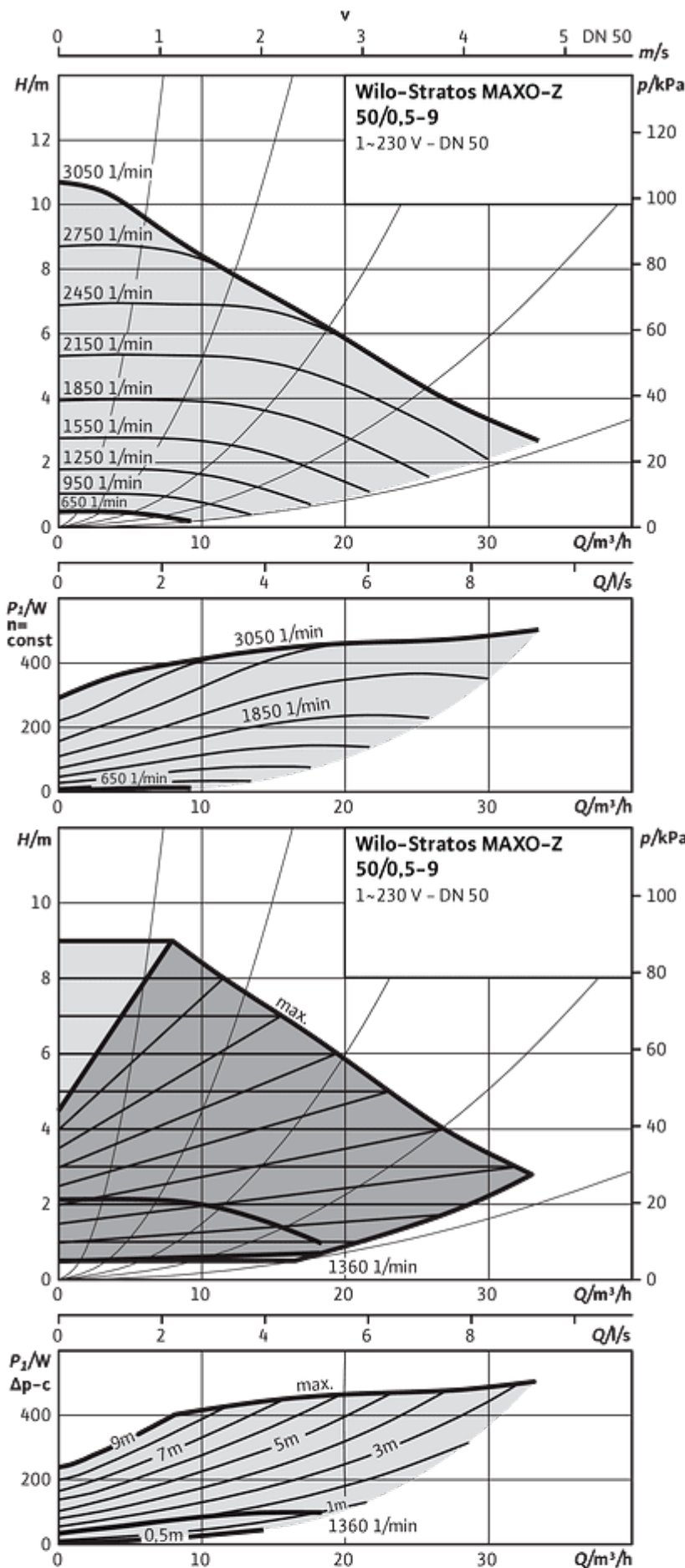

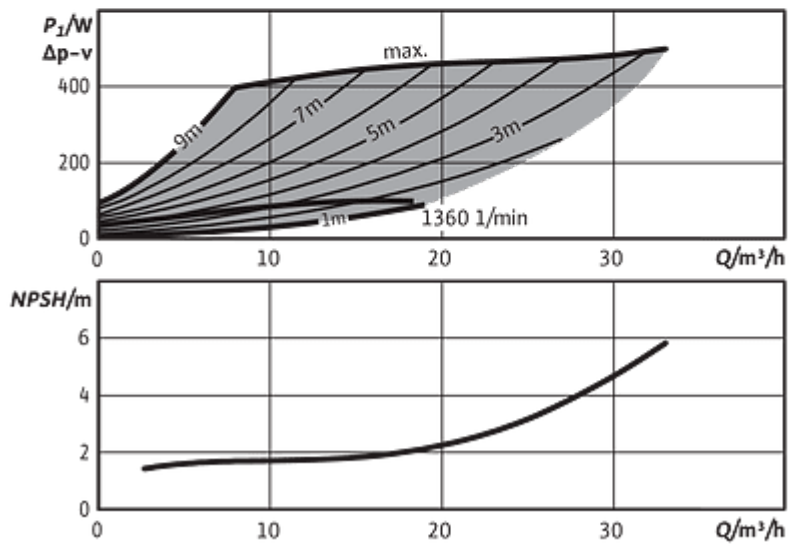

Stratos MAXO-Z 50/0,5-9 PN 6/10

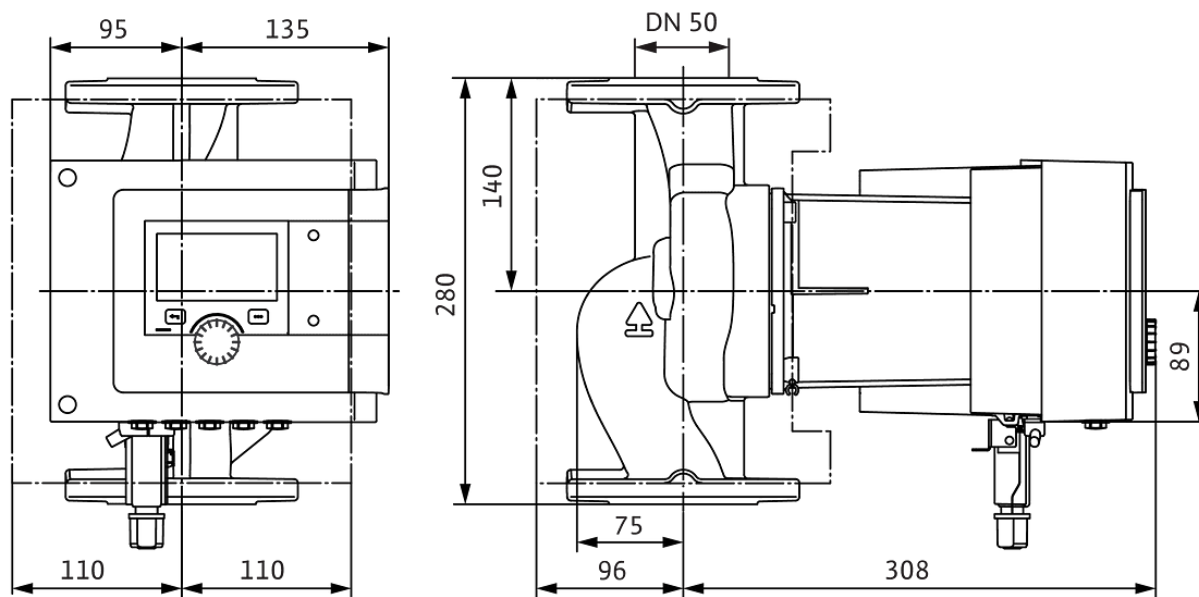

Standard: 1~ 230 V, 50/60 Hz, Option: 3~ 230 V, 50/60 Hz

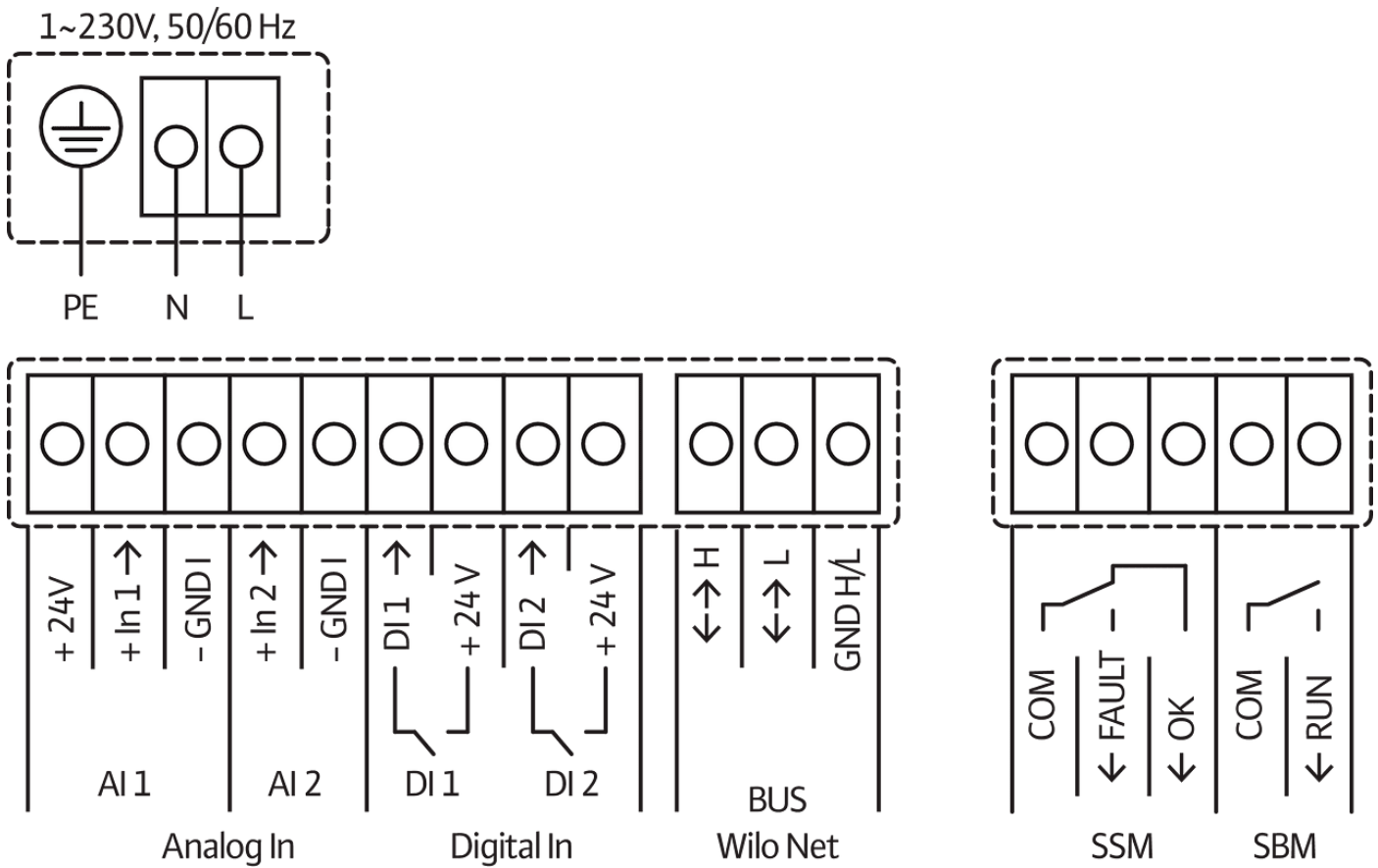

SSM: Collective fault signal (NC contact in accordance with VDI 3814, load capacity 1 A, 250 V ~)

Product data

Brand	Wilo
Product description	Stratos MAXO-Z 50/0,5-9
Article number	2164676
EAN number	4048482700182
Colour	Green/black/silver
Minimum order quantity	1
Date of sales availability	2018-11-01

Dimension, weight

Length with packaging	600 mm
Length <i>L</i>	404 mm
Height with packaging	394 mm
Height <i>H</i>	280 mm
Width with packaging	400 mm
Width <i>W</i>	250 mm
Gross weight, approx. <i>m</i>	20.1 kg
Net weight, approx. <i>m</i>	17 kg

Packaging

Number per layer	4
Packaging property	Transport packaging
Packaging type	Cardboard box
Pieces per pallet	8

Premium smart-pump Wilo-Stratos MAXO-Z

High-efficiency inline glandless pump with EC motor and electronic power adjustment. Can be used for drinking water, cold water, heating water and water/glycol mixtures. Energy efficiency index (EEI) between ≤ 0.17 and ≤ 0.19 depending on pump type.

Control modes:

- > Permanent, automatic performance adaptation to system requirements without setpoint specification **Wilo Dynamic Adapt plus**. Up to 20% energy savings compared to dp-v control mode.
- > Constant temperature (**T-const.**, factory setting)
- > Constant differential temperature (**dT-const.**)
- > Needs-based volume flow optimisation of the feeder pump through connectivity and communication between multiple pumps (**Multi-Flow Adaptation**).
- > Constant volume flow (**Q-const.**)
- > Differential pressure control (dp-c) to a remote point in the pipe network (**index circuit evaluator**)
- > Constant differential pressure (**dp-c**)
- > Variable differential pressure (**dp-v**) with the option to set the nominal duty point
- > Constant speed (**n-const.**)
- > User-defined **PID** control

Functions:

- > Heat quantity measurement
- > Cooling quantity measurement
- > Pump automatically deactivates when no flow is detected (**No-Flow Stop**)
- > Switchover between heating and cooling mode (automatic, external or manual)
- > Adjustable volume flow limiter using the Q-Limit function (**Q_{min.}** and **Q_{max.}**)
- > Operating modes of twin-head pumps: Efficiency-optimised **parallel operation** for dp-c and dp-v, main and standby operation
- > Ability to save and restore configured pump settings (**3 restoration points**)
- > **Fault and warning messages** shown in plain text with advice on resolving the issue
- > **Pump venting function** for automatic venting of the rotor chamber
- > Automatic **setback operation**
- > Automatic **deblocking function** and integrated **full motor protection**
- > **Dry-running detection**
- > Automatic detection of thermal disinfection (for domestic hot water circulation) in conjunction with a separate temperature sensor

Operating data

Fluid media	Water
Fluid temperature <i>T</i>	0 °C
Ambient temperature <i>T</i>	0 °C
Maximum operating pressure <i>PN</i>	10 bar
Minimum suction head at 50 °C <i>m</i>	5.0 m
Minimum suction head at 95 °C <i>m</i>	12.0 m
Minimum suction head at 110 °C	18.0 m
Max. permitted total water hardness	3.57 mmol/l (20°dH)

Motor data

Energy efficiency index (EEI)	0.17
Interference emission	EN 61800-3;2004+A1;2012 /residential area (C1)
Interference immunity	EN 61800-3;2004+A1;2012 /industrial environment (C2)
Mains connection	1~230 V, 50/60 Hz
Power consumption <i>P_{1max}</i>	550.0 W
Min. speed <i>n_{min}</i>	650 1/min
Max. speed <i>n_{max}</i>	3050 1/min
Protection class motor	IPX4D
Threaded cable connection	5 x M16x1.5

Materials

Pump housing	Stainless steel
Impeller	PPS-GF40
Shaft	1.4122, DLC-coated
Bearing	Carbon-graphite

Installation dimensions

Pipe connection on the suction side <i>DN_s</i>	DN 50
Pipe connection on the pressure side <i>DN_d</i>	DN 50
Port-to-port length <i>L₀</i>	280 mm

Display:

- > Control mode
- > Setpoint
- > Volume flow
- > Temperature
- > Power consumption
- > Electric consumption
- > Active influences (e.g. STOP, No-Flow Stop)

Version:

- > **2** configurable **analogue inputs**: 0–10 V, 2–10 V, 0–20 mA, 4–20 mA and commercially available PT1000; +24 V DC power supply
- > **2** configurable **digital inputs** (Ext. OFF, Ext. Min, Ext. Max, heating/cooling, manual override (uncoupled from building automation), operation lock (key lock and remote operation configuration protection))
- > **2** configurable **signal relays** for **operational and fault messages**
- > **Slot for Wilo-CIF modules** with interfaces for building automation BA (optional accessories: CIF modules Modbus RTU, Modbus TCP, BACnet MS/TP, BACnet IP, LON, PLR, CAN)
- > Wilo Net as a Wilo system bus for communication between Wilo products, e.g. **Multi-Flow Adaptation**; double pump operation and Wilo-Smart Gateway
- > **Integrated temperature sensor**
- > Automatic **emergency operation** with definable pump speed for exceptional circumstances, e.g. bus communication or sensor value malfunction
- > **Graphic colour display** (4.3 inches) with one-button manual operation
- > Use the Wilo-Assistant app to read and set operating data and –among other things– set up a commissioning protocol through the Bluetooth interface (no further accessories required)
- > Cable break detection when using an analogue signal (in connection with 2–10 V or 4–20 mA)
- > Outdoor installation with weather protection possible in accordance with the installation and operating instructions
- > Pre-set date and time
- > Thermal insulation shell for heating applications

Scope of delivery:

- > Pump
- > Optimised Wilo-Connector
- > 2x threaded cable connection M16 x 1.5
- > Washers for flange screws M12 and M16 (for nominal connection diameters DN 32 to DN 65)
- > 2x gaskets for threaded connection

Information for order placements

Brand	Wilo
Product description	Stratos MAXO-Z 50/0,5-9
Net weight, approx. <i>m</i>	17 kg
Article number	2164676

- Thermal insulation shell
- Concise Installation and operating instructions

Optional accessories:

- ClimaForm cold insulation to avoid the formation of condensate
- CIF module: Modbus TCP, Modbus RTU, BACnet IP, BACnet MS/TP, LON, PLR, CAN
- PT 1000 (B) pipe contact sensor (for domestic hot water)
- PT 1000 (AA) sensor for installation in immersion well
- Differential pressure sensor
- Smart Gateway