

8SCD5/15/5 T L05

Technical data

Company name
Contact
Phone number
e-mail address

Operating data

1	Pumpe type	Single head pump	Fluid	Water, pure
2	No. of pumps	1	Operating temperature t A	°C 4
3	Nominal flow	m ³ /h 0	pH-value at t A	7
4	Nominal head	m 0	Density at t A	kg/m ³ 1000
5	Static head	m 0	Kin. viscosity at t A	mm ² /s 1.569
6	Inlet pressure	kPa 0	Vapor pressure at t A	kPa 100
7	Environmental temperature	°C 20	Solids	0
8	Available system NPSH	m 0	Altitude	m 0

Pump data

9	Design	Borehole pumps			
10	Execution				
11	Operating speed	rpm 2900	Impeller Ø	Max. designed	mm 0
12	Number of stages	5		Min.	mm 0
13	Suction nozzle	protected by strainer		Nominal	m ³ /h ()
14	Discharge nozzle	/	Flow	Max-	m ³ /h 10.8
15	Max. casing pressure	kPa		Min-	m ³ /h 4
16	Max. working pressure	kPa 539.8	Head	Nominal	m
17	Impeller type			at Qmax	m 24.8
18	Head H(Q=0)	m 55		at Qmin	m 48.6
19	Max. shaft power	kW 1.6	Shaft power	kW ()	
20	Total weight	kg 19.2	Efficiency	%	
21			NPSH 3%	m	

Materials

22		Pump		
23	Head	Stainless steel / ASTM A743 CF8	Upper head	Technopolymer
24	Capacitor	-	Upper bearing support	Stainless steel / AISI 304
25	Connection container	PA66-GF25	Sleeve with wound stator	Stainless steel / AISI 304
26	Motor shaft	Stainless steel / AISI 431	Internal mech. seal (rotary part)	Carbographite
27	Lower bearing support	Die-cast aluminium	Internal mech. seal (fixed part)	Steatite
28	Lower head	Technopolymer	External mech. seal	Silicon carbide / Silicon carbide / NBR
29	Final bowl	Stainless steel / AISI 304	Pump shaft	Stainless steel / AISI 431
30	Diffuser	Stainless steel / AISI 304	Pump body	Stainless steel / AISI 304
31	Impeller	Technopolymer	Base	Aluminium
32	Elastomers	Nitrile rubber (NBR)	Sleeve	Stainless steel / AISI 304
33	Capacitor housing spacer	PA66-GF25	PLUG	Stainless steel / AISI 304
34				
35				
36				
37				
38				
39				
40				
41				

Motor data

42	Manufacturer	Type	MOT_8SC5/15/5T	Cable type		
43	Specific design	Three phase pump motor		Cable cross section	mm ²	
44	Rated power	1.5 kW	Phases	3	Environmental temperature	°C 20
45	Corrected motor power	1.5 kW	No. starts / h	max. 20	cable length	m
46	coolant speed	min.	Weight	0 kg		
47	Rated current	3.8 A	Electric voltage	400 V		
48	Reduced current	3.8 A	Starting mode	Directly		
49	Degree of protection	IP 68	Speed	2850 rpm		
50	motor connection		Installation			

Remarks

Remarks					

Project	Project ID	Created by Joshua Harvey	Created on 04-07-21	Last update 04-07-21
---------	------------	-----------------------------	------------------------	-------------------------

8SCD5/15/5 T L05

Performance curve

Company name
Contact
Phone number
e-mail address

	Ø mm	Pump capacity			Pump head		Shaft power P2			Frequency	Hz	50
		Operating range Min. m³/h	Max. m³/h	η Max. m³/h	H(Q=0) m	η Max. m	P2(Q=0) kW	Max. kW	η Max. kW	Operating speed	rpm	2900
actual	0	4	10.8	7.57	55	39.9		1.56	1.42	Nominal flow	m³/h	0
Min.	0	/	/	7.57	55	39.9		/	1.42	Nominal head	m	0
Max.	0	/	/	7.57	55	39.9		/	1.42	Inlet pressure	kPa	0
										Static head	m	0

Power datas referred to:

hydr. Performance acceptance acc. To EN ISO 9906 Class Grade

Water, pure [100%] ; 4°C; 1000kg/m³; 1.57mm²/s

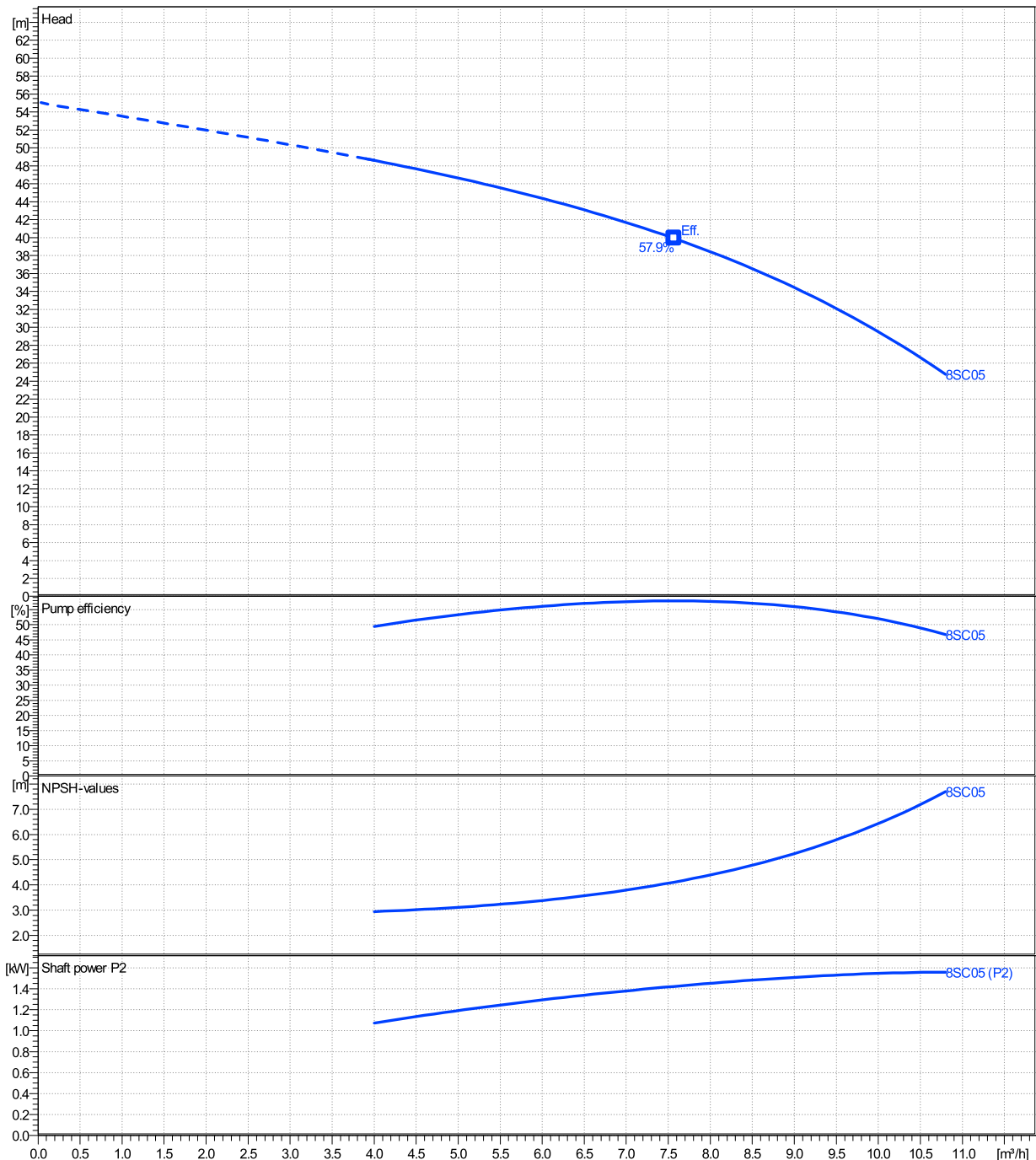

Project	Project ID	Created by Joshua Harvey	Created on 04-07-21	Last update 04-07-21
---------	------------	-----------------------------	------------------------	-------------------------

8SCD5/15/5 T L05

Dimensions

Company name
Contact
Phone number
e-mail address

Standard

Three phase pump motor
MOT_8SC5/15/5T

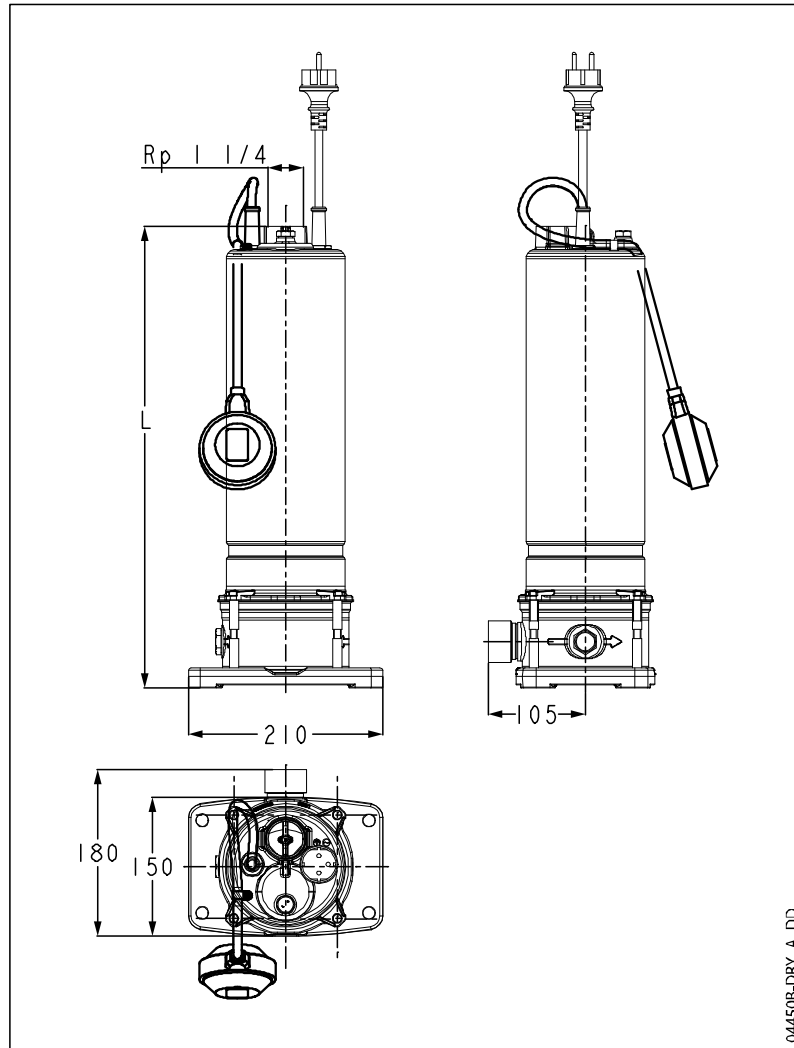

Dimensions [mm]	
L	618
Weight (+/- 5%) [kg]	
Pump	19.3 kg
Cable	
Motor	
Total weight	
Connections	
Suction nozzle protected by strainer	Discharge nozzle

Dimensions and weight without obligation

Project	Project ID	Created by Joshua Harvey	Created on 04-07-21	Last update 04-07-21
---------	------------	-----------------------------	------------------------	-------------------------