

## 8SCD3/09/5 T L05

<b>Technical data</b>	<b>Company name</b>	
	<b>Contact</b>	
	<b>Phone number</b>	
	<b>e-mail address</b>	

Operating data				
1	Pumpe type	Single head pump	Fluid	Water, pure
2	No. of pumps	1	Operating temperature t A	°C 4
3	Nominal flow	m <sup>3</sup> /h 0	pH-value at t A	7
4	Nominal head	m 0	Density at t A	kg/m <sup>3</sup> 1000
5	Static head	m 0	Kin. viscosity at t A	mm <sup>2</sup> /s 1.569
6	Inlet pressure	kPa 0	Vapor pressure at t A	kPa 100
7	Environmental temperature	°C 20	Solids	0
8	Available system NPSH	m 0	Altitude	m 0

Pump data				
9	Design	Borehole pumps		
10	Execution		Impeller Ø	Max. mm 0
11	Operating speed	rpm 2900	designed	mm
12	Number of stages	3	Min.	mm 0
13	Suction nozzle	protected by strainer	Nominal	m <sup>3</sup> /h ( )
14	Discharge nozzle	/	Flow	Max- m <sup>3</sup> /h 10.8
15	Max. casing pressure	kPa	Min-	m <sup>3</sup> /h 4
16	Max. working pressure	kPa 319.5	Head	Nominal m
17	Impeller type		at Qmax	m 16
18	Head H(Q=0)	m 33	at Qmin	m 28.7
19	Max. shaft power	kW .9	Shaft power	kW ( )
20	Total weight	kg 16.3	Efficiency	%
21			NPSH 3%	m

Materials				
22		Pump		
23	Head	Stainless steel / ASTM A743 CF8	Upper head	Technopolymer
24	Capacitor	-	Upper bearing support	Stainless steel / AISI 304
25	Connection container	PA66-GF25	Sleeve with wound stator	Stainless steel / AISI 304
26	Motor shaft	Stainless steel / AISI 431	Internal mech. seal (rotary part)	Carbographite
27	Lower bearing support	Die-cast aluminium	Internal mech. seal (fixed part)	Steatite
28	Lower head	Technopolymer	External mech. seal	Silicon carbide / Silicon carbide / NBR
29	Final bowl	Stainless steel / AISI 304	Pump shaft	Stainless steel / AISI 431
30	Diffuser	Stainless steel / AISI 304	Pump body	Stainless steel / AISI 304
31	Impeller	Technopolymer	Base	Aluminium
32	Elastomers	Nitrile rubber (NBR)	Sleeve	Stainless steel / AISI 304
33	Capacitor housing spacer	PA66-GF25	PLUG	Stainless steel / AISI 304
34				
35				
36				
37				
38				
39				
40				
41				

Motor data				Cable	
42	Manufacturer	Type	MOT_8SC3/09/5T	Cable type	
43	Specific design	Three phase pump motor		Cable cross section	mm <sup>2</sup>
44	Rated power	0.9 kW	Phases	3	Environmental temperature
45	Corrected motor power	0.9 kW	No. starts / h	max. 20	cable length
46	coolant speed	min.	Weight	0 kg	
47	Rated current	2.53 A	Electric voltage	400 V	
48	Reduced current	2.53 A	Starting mode	Directly	
49	Degree of protection	IP 68	Speed	2850 rpm	
50	motor connection		Installation		

Remarks				

Project	Project ID	Created by Joshua Harvey	Created on 04-07-21	Last update 04-07-21
---------	------------	-----------------------------	------------------------	-------------------------

## 8SCD3/09/5 T L05

### Performance curve

Company name  
Contact  
Phone number  
e-mail address

	Ø mm	Pump capacity			Pump head		Shaft power P2			Frequency		Hz	50
		Operating range Min. m³/h	Max. m³/h	η Max. m³/h	H(Q=0) m	η Max. m	P2(Q=0) kW	Max. kW	η Max. kW	Operating speed rpm	2900		
actual	0	4	10.8	7.75	32.6	23.4		0.929	0.851	Nominal flow	m³/h	0	
Min.	0	/	/	7.75	32.6	23.4		/	0.851	Nominal head	m	0	
Max.	0	/	/	7.75	32.6	23.4		/	0.851	Inlet pressure	kPa	0	
										Static head	m	0	

**Power datas referred to:**

hydr. Performance acceptance acc. To EN ISO 9906 Class Grade

Water, pure [100%] ; 4°C; 1000kg/m³; 1.57mm²/s

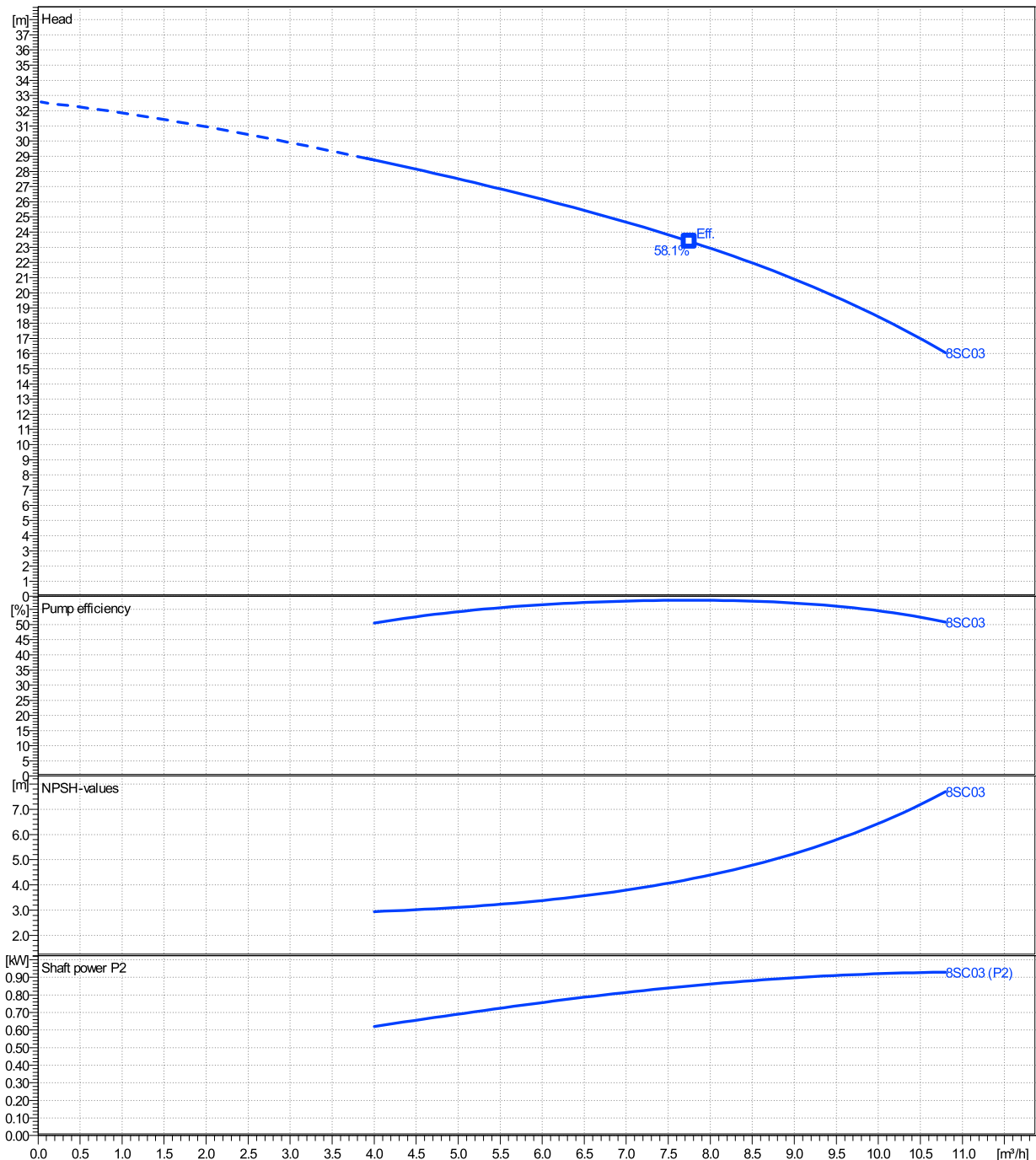

Project	Project ID	Created by Joshua Harvey	Created on 04-07-21	Last update 04-07-21
---------	------------	-----------------------------	------------------------	-------------------------

**8SCD3/09/5 T L05**

**Dimensions**

Company name  
Contact  
Phone number  
e-mail address

Standard

Three phase pump motor  
MOT\_8SC3/09/5T

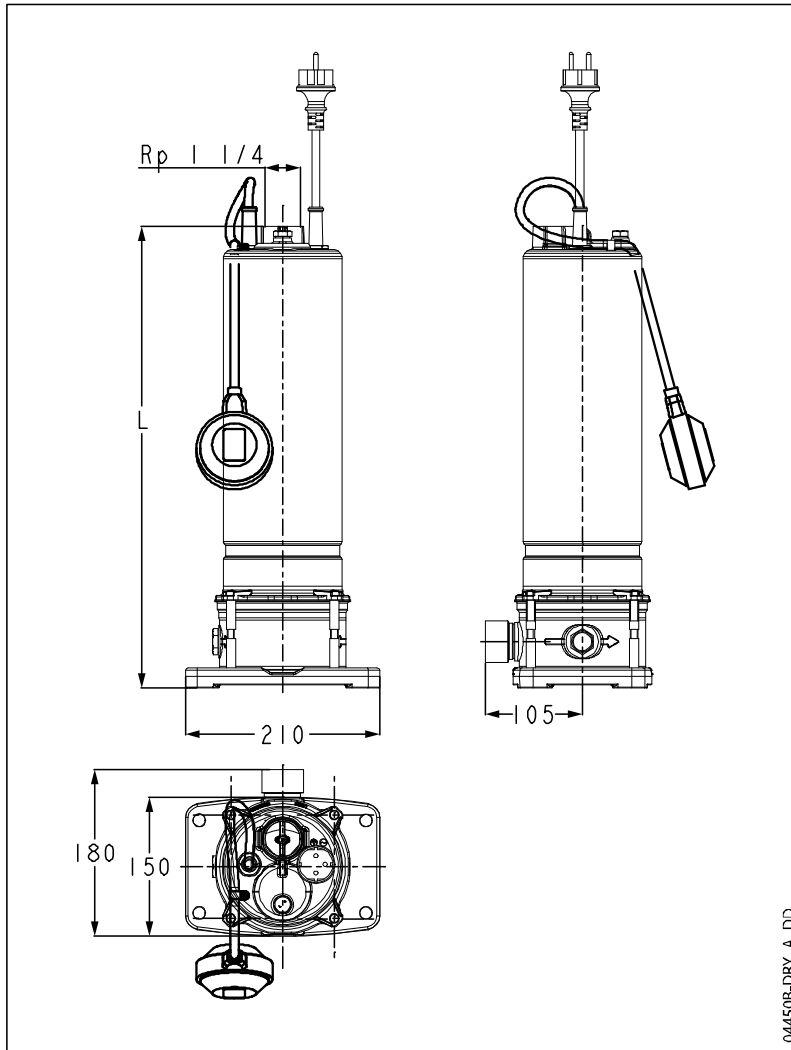

Dimensions [ mm ]	
L	513
Weight (+/- 5%) [ kg ]	
Pump	16 kg
Cable	
Motor	
Total weight	
Connections	
Suction nozzle protected by strainer	Discharge nozzle

**Dimensions and weight without obligation**

Project	Project ID	Created by <b>Joshua Harvey</b>	Created on <b>04-07-21</b>	Last update <b>04-07-21</b>
---------	------------	------------------------------------	-------------------------------	--------------------------------