

DNM 115 CG

Company	Anglian Pumping Services	Customer	Date	11/26/2020
Contact	Joshua Harvey	Contact	List price	Price on req.
Project		Phone number	Family code	
Project no.		Email	Item no.	107550120XSA

Performance according to ISO 9906:2012 – Grade 3B

Power datas referred to:

Water, pure [100%] ; 4°C; 1000kg/m³; 1.57mm²/s

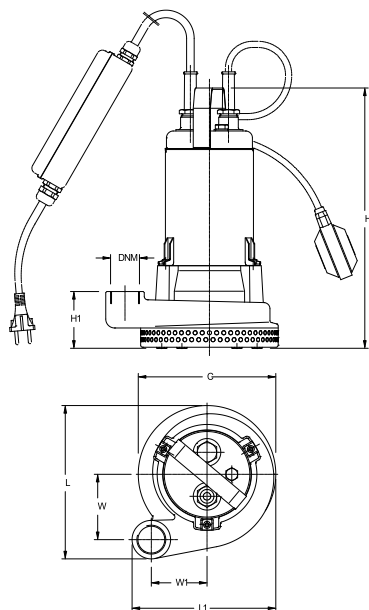
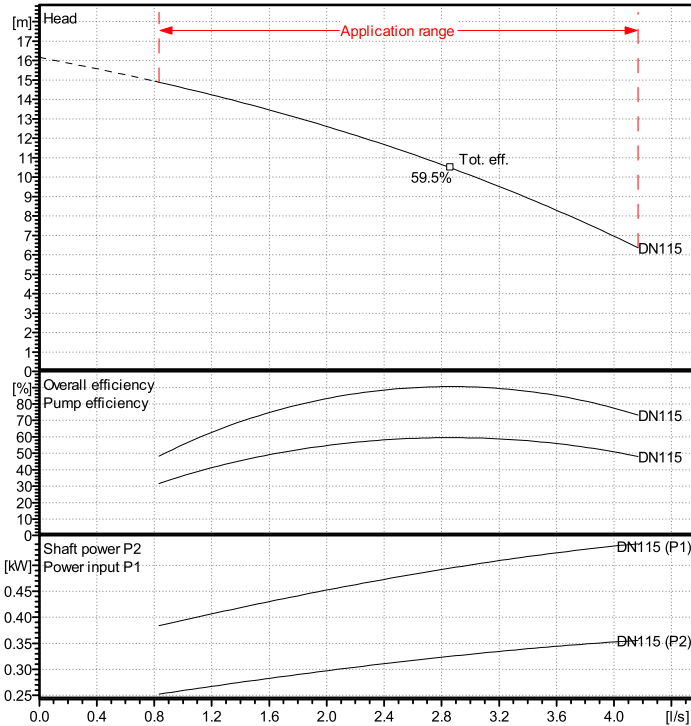

Operating Data Specification

Flow	0 l/s
Head	0 m

Hydraulic data (duty point)

Flow	
Head	
Power input	

Pump data

Make	Lowara
Type	DNM 115 CG Submersible drainage pump
Speed	2900
Head H(Q=0)	16.2 m
Suction side	
Discharge side	
Types of installation	Submersible pump
Weight	18.5 kg

Materials / seals

Pump body	Cast Iron
Impeller	Steel + Nitrile Rubber XNBR
Wearing flange	Stainless steel
Suction strainer	Stainless steel

Shaft Seal

Rotating Assembly	U3-Tungsten Carbide
Fixed Assembly	U3-Tungsten Carbide
Elastomers	V-FPM
Springs	F-AISI 304
Other Components	F-AISI 304

Motor data

Rated power P2	0.6 kW	Nom. Speed	2860 rpm
Frequency	50	Phase	1~
Rated voltage	230 V	Rated current	4.28 A
Protection class	IP X8	Insulation class	F
Permitted voltage tolerance +/- 10%			

Dimensions mm

C	O 200	W	95
DNM	Rp 1 1/4	W1	81
H	380		
H1	81		
L	223		
L1	209		

Note: