

Clamlike®

air



18 INCH HIGH VELOCITY PEDESTAL FAN MODEL NO: CPF18B100

PART NO: 3231535

OPERATION & MAINTENANCE INSTRUCTIONS



ORIGINAL INSTRUCTIONS

LS0720 - ISS 2

INTRODUCTION

Thank you for purchasing this CLARKE 18 inch High Velocity Pedestal Fan.

Before attempting to use this product, please read this manual thoroughly and follow the instructions carefully. In doing so you will ensure the safety of yourself and that of others around you, and you can look forward to your purchase giving you long and satisfactory service.

GUARANTEE

This product is guaranteed against faulty manufacture for a period of 12 months from the date of purchase. Please keep your receipt which will be required as proof of purchase.

This guarantee is invalid if the product is found to have been abused or tampered with in any way, or not used for the purpose for which it was intended.

Faulty goods should be returned to their place of purchase, no product can be returned to us without prior permission.

This guarantee does not effect your statutory rights.

ENVIRONMENTAL RECYCLING POLICY



Through purchase of this product, the customer is taking on the obligation to deal with the WEEE in accordance with the WEEE regulations in relation to the treatment, recycling & recovery and environmentally sound disposal of the WEEE.

In effect, this means that this product must not be disposed of with general household waste. It must be disposed of according to the laws governing Waste Electrical and Electronic Equipment (WEEE) at a recognised disposal facility.

ELECTRICAL CONNECTIONS



WARNING: READ THESE ELECTRICAL SAFETY INSTRUCTIONS THOROUGHLY BEFORE CONNECTING THE PRODUCT TO THE MAINS SUPPLY.

Before switching the product on, make sure that the voltage of your electricity supply is the same as that indicated on the rating plate. This product is designed to operate on 230VAC 50Hz. Connecting it to any other power source may cause damage.

This product may be fitted with a non-rewireable plug. If it is necessary to change the fuse in the plug, the fuse cover must be refitted. If the fuse cover becomes lost or damaged, the plug must not be used until a suitable replacement is obtained.

If the plug has to be changed because it is not suitable for your socket, or due to damage, it should be cut off and a replacement fitted, following the wiring instructions shown below. The old plug must be disposed of safely, as insertion into a mains socket could cause an electrical hazard.



**WARNING: THE WIRES IN THE POWER CABLE OF THIS PRODUCT ARE COLOURED IN ACCORDANCE WITH THE FOLLOWING CODE:
BLUE = NEUTRAL BROWN = LIVE YELLOW AND GREEN = EARTH**

If the colours of the wires in the power cable of this product do not correspond with the markings on the terminals of your plug, proceed as follows.

- The wire which is coloured **Blue** must be connected to the terminal which is marked **N** or coloured **Black**.
- The wire which is coloured **Brown** must be connected to the terminal which is marked **L** or coloured **Red**.
- The wire which is coloured **Yellow and Green** must be connected to the terminal which is marked **E** or  or coloured **Green**.

Plug must be BS1363/A approved.

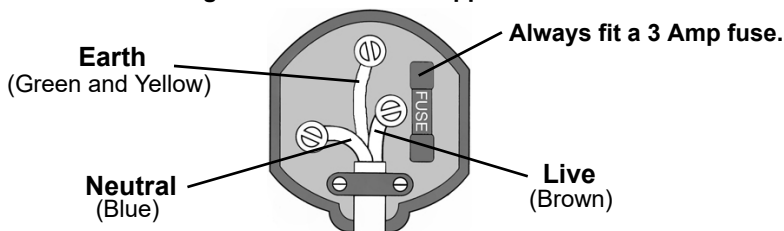

Ensure that the outer sheath of the cable is firmly held by the clamp

We strongly recommend that this machine is connected to the mains supply via a Residual Current Device (RCD)

If in any doubt, consult a qualified electrician. DO NOT attempt any repairs yourself.

ASSEMBLY

1. Remove the two screws from the supporting tube.
2. Slide the supporting tube into the fan bracket.
3. Fix in place using two screws supplied.

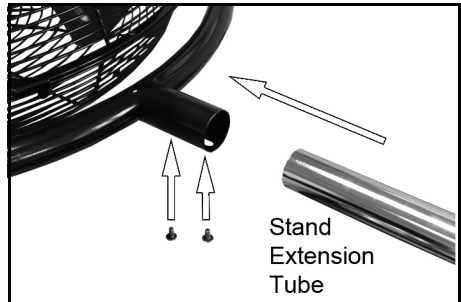

4. Remove the base locking screw and the fixing plate from the stand.
5. Fit the weighted block and base and screw securely into the bottom of the stand as shown.

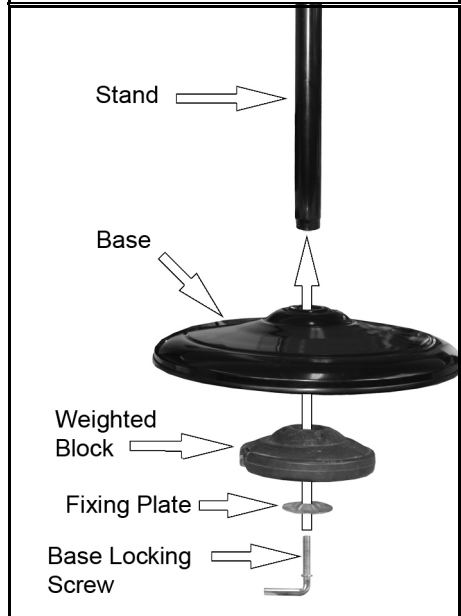

OPERATION

SAFETY PRECAUTIONS

- **DO NOT** use in dusty environments.
- Indoor use only.
- **DO NOT** use in environments with high fumes from chemicals etc.
- **DO NOT** use as an extractor fan.
- **DO NOT** use in areas of high humidity/water vapour, i.e. bathrooms etc.
- **DO NOT** connect fan to ducting system.
- **DO NOT** cover the fan with clothing or any material that will restrict free airflow through the fan
- Never touch the blades with your hand or any object.

TILTING THE FAN

You can adjust the angle of the fan by holding the supporting tube and tilting the fan to the required angle.

- Tighten the nuts on the side of the fan slightly if the fan will not stay in position.

ADJUSTING THE SPEED

Press the relevant button to select the fan speed required:

- Button 0 - Off
- Button 1 - 950 rpm
- Button 2 - 1080 rpm
- Button 3 - 1250 rpm

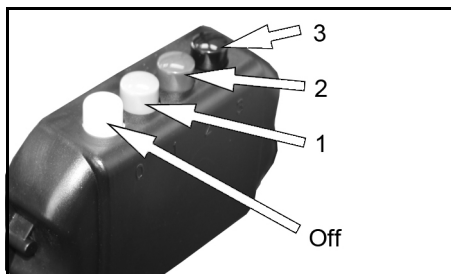

ADJUSTING THE HEIGHT

1. Loosen the height adjustment knob.
2. Raise or lower the fan to the required height.
3. Tighten the height adjustment knob to lock the fan in the new position.

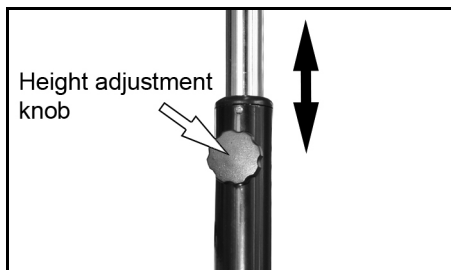

MAINTENANCE

WARNING: NEVER OPERATE THE FAN WITH THE GRILLE REMOVED.



-
- The motor bearings are permanently sealed and do not require any additional lubrication.
 - Have any repairs carried out by a suitably qualified person.

CLEANING

1. Disconnect the power cord from the mains power supply.
2. Lift the guard clips and remove the single bolt and nut at the bottom of the guard
3. Remove the guard carefully.
4. Wipe the fan blades with dry cloth.
 - Never use polish or any corrosive liquid that will damage the paint, metal or plastic.
 - Do not bend the blades!
5. Replace the guard so that the bolt holes in the front and rear guard line up and lock the guard securely before use.
 - Make sure that the guard clips are returned to the locked position.

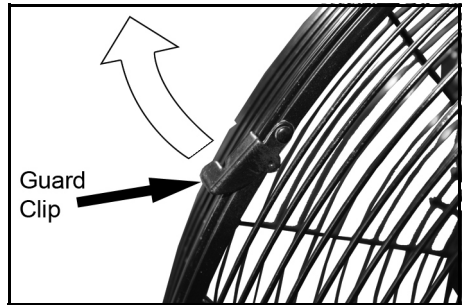

SPECIFICATIONS

Part No:	3231535
Voltage:	230 V AC (50Hz)
Fan Speeds	3
	Setting 1 950 RPM
	Setting 2 1080 RPM
	Setting 3 1250 RPM
Dimensions (L x W x H):	450 x 557 x (1060-1335 ±2) mm
Weight:	8.85 kg
Maximum Fan flow Rate (m ³ /min)	156.43 (m ³ /min)
Fan Power Input (W)	104.40 W
Service Value (m ³ /min) / (W)	1.50 (m ³ /min) / (W)
Sound Power level: dB LWa (Directive 2009/125/EC)	64.54 dB
Maximum Air Velocity (m/ s)	4.17 m/s
Seasonal Electricity consumption (kWh/annum)	33.41 kWh/annum
Measurement standard for service value	IEC 60879:1986 (corr.1992)
Contact details for obtaining more information	Clarke International Hemnall Street, Epping, Essex CM16 4LG, England

DECLARATION OF CONFORMITY



Clarke[®]
INTERNATIONAL

Hemnall Street, Epping, Essex CM16 4LG

DECLARATION OF CONFORMITY

This is an important document and should be retained.

We hereby declare that this product(s) complies with the following directive(s):

2014/30/EU *Electromagnetic Compatibility Directive.*
2014/35/EU *Low Voltage Equipment Directive.*
2011/65/EU *Restriction of Hazardous substances.*
2009/125/EC *Eco-design Requirements Directive.*

The following standards have been applied to the product(s):

*EN 55014-1:2006+A1:2009+A2:2011, EN 55014-2:2015, EN 61000-3-3:2013,
EN 60335-2-80:2003 +A1:2004+A2:2009, EN 62233:2008, EN 61000-3-2:2014,
EN 60335-1:2012 +A11:2014.*

The technical documentation required to demonstrate that the product(s) meet(s) the requirement(s) of the aforementioned directive(s) has been compiled and is available for inspection by the relevant enforcement authorities.

The CE mark was first applied in: 2017

Product Description: 18inch Black Floor Fan, 18inch Pedestal Fan
Model number(s): CFF18B100, CPF18B100
Serial / batch Number: N/A
Date of Issue: 19/09/2017

Signed:

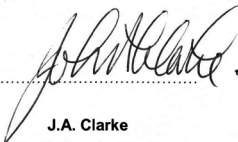
.....
J.A. Clarke
Director